

2008

Design of Media Access Control Schemes for Performance Enhancement of Future Generation Wireless Systems

Dan James Dechene
Western University

Follow this and additional works at: <https://ir.lib.uwo.ca/digitizedtheses>

Recommended Citation

Dechene, Dan James, "Design of Media Access Control Schemes for Performance Enhancement of Future Generation Wireless Systems" (2008). *Digitized Theses*. 4185.
<https://ir.lib.uwo.ca/digitizedtheses/4185>

This Thesis is brought to you for free and open access by the Digitized Special Collections at Scholarship@Western. It has been accepted for inclusion in Digitized Theses by an authorized administrator of Scholarship@Western. For more information, please contact wlsadmin@uwo.ca.

Design of Media Access Control Schemes for Performance Enhancement of Future Generation Wireless Systems

(Spine title: Design of MAC Schemes for Wireless Systems)

(Thesis format: Monograph)

by

Dan James Dechene

Graduate Program
in
Engineering Science
Electrical and Computer Engineering

A thesis submitted in partial fulfillment
of the requirements for the degree of
Master of Engineering Science

Faculty of Graduate Studies
The University of Western Ontario
London, Ontario, Canada

© Dan J. Dechene 2008

Certificate of Examination

THE UNIVERSITY OF WESTERN ONTARIO
FACULTY OF GRADUATE STUDIES
CERTIFICATE OF EXAMINATION

Chief Advisor:

Dr. Abdallah Shami

Examining Board:

Dr. Serguei Primak

Advisory Committee:

Dr. Xianbin Wang

Dr. Hanan Lutfiyya

The thesis by

Dan J. Dechene

entitled:

**Design of Media Access Control Schemes for Performance Enhancement
of Future Generation Wireless Systems**

is accepted in partial fulfillment of the
requirements for the degree of

Master of Engineering Science

Date: _____

Chair of Examining Board
Dr. Abdelkader Ouda

Abstract

Wireless Local Area Networks (WLANs) now provide connectivity to many businesses, homes and educational institutions. The wireless channel itself is plagued with numerous problems, such as it does not natively allow sharing of the wireless resource. WLAN devices utilize a complex medium access control (MAC) mechanism to allow multiple users to share the wireless resource. The distributed coordination function (DCF) is the most commonly used multiple access scheme in WLANs and a member of the 802.11 standard [1].

In this thesis, two major roles of MAC protocols are examined: maximizing network throughput and service differentiation. Firstly, a novel MAC scheme is proposed that makes use of Multiple-Input, Multiple-Output (MIMO) antenna technology to improve overall network throughput. The proposed MIMO-Aware MAC (MA-MAC) scheme utilizes the beamforming feature available in MIMO systems to allow two simultaneous transmissions of the wireless channel overlapped in time. This results in increased aggregate network throughput. This proposed scheme is shown to offer better throughput and delay performance versus existing MAC schemes proposed for simultaneous transmission. In addition, this MAC scheme is able to achieve this performance in a manner compatible with the existing standard.

The latter part of this thesis proposes a new Time Division Multiple Access (TDMA) based scheme for providing video, voice and data services (also known as the Triple-Play services) in a point-to-multipoint network. By dynamically allocating transmission slots, the proposed Television TDMA (TV-TDMA) scheme is shown to better meet delay requirements for video and voice traffic, and is able to achieve higher overall saturation throughput for best-effort traffic than existing Quality of Service enabled protocols.

Acknowledgements

I would like to take this opportunity to first and foremost thank my thesis supervisor Dr. Abdallah Shami for his invaluable insights and guidance while pursuing this work. Without his mentoring and experience I would not be where I am today. He has helped make my graduate experience an enjoyable one.

Thank you also to everyone in my lab for all your help and experience. I found our frequent discussions both beneficial and interesting. And also thank you for all the coffee throughout the day (quite frequently). A great thank you to all the staff and faculty here for helping to make this a great experience. A special thank you for the ECE office staff who put up with my shenanigans on a routine basis.

I would also like to thank my parents. I would not be here without them (both literally and figuratively). My father has always been supportive saying that I will do great things. My mother has always been so caring and without her I am sure I would still be forgetting my keys every day. Both have been instrumental in my continuing development.

I would like to thank the love of my life Jessica. You have been very supportive and understanding when I needed to work late and have been an inspiration. I am truly happy you are a part of my life.

I would like to acknowledge the financial support I received through the University of Western Ontario, the National Sciences and Engineering Research Council (NSERC), the Ontario Centres of Excellence (OCE) and Broadband Wizard Inc., which was vital in giving me the opportunity to pursue my degree.

And lastly thank you to all my friends who have been great throughout my studies by keeping me sane. Through the many wing nights, LORHA hockey games, and lots of Guitar Hero, it's been great!

Table of Contents

Certificate of Examination	ii
Abstract	iii
Acknowledgement	iv
List of tables	vii
List of figures	viii
Acronyms	x
1 Introduction	1
1.1 Thesis Outline	2
2 Background	3
2.1 Multiple-Input Multiple-Output Antenna Systems	6
2.1.1 Capacity Improvements offered by MIMO Channels	6
2.1.2 MAC Improvement Using MIMO	8
2.2 Wireless Video Transmission	11
2.2.1 MPEG-2 Video Formats	12
2.2.2 MPEG-2 Traffic Characteristics	13
2.3 Evaluation Platform	16
2.3.1 ns-2 - The Network Simulator	16
3 MIMO-Aware Media Access Control	22
3.1 Literature Review and Motivation	22
3.1.1 Existing MIMO MAC Protocols	22
3.1.2 Motivation	24
3.2 MA-MAC Protocol	26
3.2.1 Weight Adjustment Procedure	26
3.2.2 RTS/CTS Control Packet Format	29
3.2.3 Protocol Operation	30
3.3 Performance Results	37
3.3.1 Saturated Performance	38
3.3.2 Unsaturated Performance	42
3.4 Protocol Remarks	45

Table of Contents

4	Television Time-Division Multiple Access	46
4.1	Motivation	46
4.1.1	System Requirements	46
4.1.2	Existing Designs	47
4.1.3	Performance of Existing Protocols	49
4.2	Protocol Operation	53
4.2.1	TV-TDMA Frame	54
4.2.2	Packet Formats	56
4.2.3	Association	60
4.2.4	MAC Scheduling Scheme	60
4.2.5	ARQ Mechanism	62
4.3	Performance Results	64
4.3.1	Video Performance	64
4.3.2	Voice Performance	66
4.3.3	Best-Effort Performance	67
4.3.4	Best-Effort Saturation Rates	68
4.4	Protocol Remarks	69
5	Conclusion	70
5.1	Future Research Work	70
	References	72
	Appendices	
	A Packet Overhead Calculations for 802.11a	75
	Curriculum Vitae	77

List of Tables

2.1	Video Encoding Target Parameters	14
3.1	MA-MAC Simulation parameters	38
3.2	MA-MAC Fairness Comparison for 6 and 12 Station Networks	42
4.1	Encoded Video Statistics	50
4.2	802.11a Physical Layer and Universal Parameters for ns-2	50
4.3	EDCF Priority Queue Parameters	51
4.4	Existing Protocols Performance Results for Video and Voice Traffic	52
4.5	Frame Control	57
4.6	Address Structure	57
4.7	TV-TDMA Parameters	64
4.8	TV-TDMA Video Stream Frame Statistics	65
4.9	TV-TDMA Voice Stream Statistics	67
4.10	TV-TDMA Best-Effort Throughput Statistics	68
4.11	TV-TDMA Best-Effort Saturation Statistics	69

List of Figures

2.1	TCP/IP Internet Model	3
2.2	Ergodic Capacity vs SNR	9
2.3	Radio Structure for Specified MIMO System	11
2.4	Proposed Point-to-Multipoint Wireless Video System	13
2.5	PDF of Frame Size for Selected Video Stream	14
2.6	Instantaneous Video Bitrate for Selected Video Stream	14
2.7	Access Point Queue Evolution for Access Point Serving 4 Stations . .	15
2.8	Mobile Node Model in ns-2	17
3.1	Throughput vs. Silence Period - 20 Stations - 1Mbps	25
3.2	Ad hoc network scenario	28
3.3	Access Control Packets	30
3.4	MA-MAC scheme timing diagram.	31
3.5	Timing diagram of MAC decision process for secondary stations. . . .	32
3.6	Weight Sensing Period Packet Formats	35
3.7	Flowchart of MA-MAC Operation	36
3.8	Pseudo-code for MA-MAC Operation	37
3.9	Performance vs Network Size under Saturated Conditions	39
3.10	Throughput vs Packet Size	40
3.11	Throughput vs Window Size	40
3.12	Throughput vs Backoff Stages	40
3.13	Throughput vs Stations	40
3.14	Unsaturated Network Scenario	43
3.15	Delay vs Downlink Packet Size under Unsaturated Conditions	43
3.16	Unsaturated Performance versus Network Size	44
3.17	PDF of Packet Delay. 10 Station Network stations.	44
4.1	Point-To-Multipoint Wireless Network Scenario	49
4.2	TV-TDMA Superframe	54
4.3	TV-TDMA Downlink Frame	55
4.4	TV-TDMA Uplink Frame	56
4.5	802.11a Packet	56
4.6	Beacon Packet	58
4.7	Payload Header	58
4.8	Video Jitter of Station 1	65
4.9	Video Jitter of Station 3	65

List of Figures

4.10 Voice Downlink Jitter for Station 4	66
4.11 Voice Uplink Jitter for Station 4	66
4.12 Downlink Best-Effort Delay PDF - Station 3	68
4.13 Uplink Best-Effort Delay PDF - Station 3	68

Acronyms

ACK	Acknowledgment
AIFS	Arbitration Inter-frame Spacing
AP	Access Point
ARP	Address Resolution Protocol
ARQ	Automatic Repeat-reQuest
CAP	Controlled Access Period
CFB	Contention Free Burst
CFP	Contention Free Period
CP	Contention Period
CTS	Clear-To-Send
CRC	Cyclic Redundancy Check
DCF	Distributed Coordination Function
DIFS	Distributed Inter-frame Spacing
DVD	Digital Video Disc
EDCF	Enhanced Distributed Coordination Function
FTP	File Transfer Protocol
fps	Frames Per Second
GOP	Group of Pictures
GHz	Gigahertz
HCCA	Hybrid Coordination Function Controlled Channel Access
Hz	Hertz
IEEE	Institute of Electrical and Electronic Engineers
IFQ	Interface Queue
kB	Kilobytes
kbps	Kilobits Per Second
MAC	Medium Access Control
Mbps	Megabits Per Second
MIMO	Multiple Input Multiple Output

Acronyms

MPEG	Moving Picture Experts Group
NAV	Network Allocation Vector
PCF	Point Coordination Function
PDA	Personal Digital Assistant
PDF	Probability Density Function
PHY	Physical
PIFS	Point-Coordination Inter-frame Spacing
PLCP	Physical Layer Convergence Procedure
PSDU	Physical Layer Service Data Unit
QoS	Quality of Service
RTP	Real-time Transport Protocol
RTS	Request-To-Send
SIFS	Short Inter-frame Spacing
SINR	Signal-to-Interference Noise Ratio
SISO	Single Input Single Output
SNR	Signal-to-Noise Ratio
TCP	Transport Control Protocol
TDMA	Time-Division Multiple Access
TS	Traffic Stream
TSPEC	Traffic Specification
UDP	User Datagram Protocol
ULMAP	Upload Map
VBR	Variable Bitrate
WLAN	Wireless Local Area Network

Chapter 1

Introduction

Wireless Local Area Networks (WLANs) have found common place this day in age. This fact is not something surprising. An individual can simply walk down the street with a laptop equipped with a wireless network card and observe numerous wireless access points. The prevalence of this technology is derived from an adaptable architecture that allows a device connected to a WLAN to be relocated without the need for changing the existing infrastructure. For this reason, more and more businesses, educational institutions and individual homes are becoming equipped with wireless technologies.

Consumer wireless devices are now available through numerous manufacturers [2, 3, 4] and in a number of form factors [5, 6]. Each wireless technology is designed with a particular application in mind. There are two major computer-oriented consumer wireless technologies predominant in the market: Bluetooth [7] and Wi-Fi [8]. The Bluetooth standard is designed for providing low-speed, short-range data transmission. It is used in many devices such as printers and other computer peripherals. Wi-Fi provides high-speed communication designed to replace existing wired connections to network devices. Current Wi-Fi devices fall under the 802.11a/b/g/n series of technologies. Each of these standards provide specific datarates and operates in a particular frequency band.

The operation of these technologies is very complex. An inherent property of wireless communication is that devices share access to the wireless medium. For this reason, these technologies require advanced mechanisms to ensure proper functionality. These mechanisms provide controlled access to the wireless channel and are vital to the successful operation of the wireless network. The design of these medium access control (MAC) schemes has drawn the attention of many researchers and industry professionals for a number of years. Even now, researchers look at methods for MAC improvement in WLANs.

Multiple-Input, Multiple-Output (MIMO) antenna technology is one such method with a possibility of providing improvements to WLANs. In this thesis, MIMO systems are utilized as a method of improving WLAN performance by use of beamforming to simultaneously schedule packets. This major contribution proposes a novel MIMO-Aware MAC (MA-MAC) protocol as a method of utilizing MIMO technology for MAC level improvement in WLANs.

In addition to controlling access to the shared medium, MAC schemes are also responsible for providing service differentiation to data traffic in a wireless network. In the latter part of this thesis, a new MAC protocol named Television Time-Division Multiple Access (TV-TDMA) is presented as an alternative to existing MAC schemes to provide service differentiation to video, voice and data traffic (also known as Triple-Play services). The protocol is designed to offer improved performance in the point-to-multipoint scenario where there is one base station providing traffic flows to several subscribing stations.

1.1 Thesis Outline

The remainder of this thesis is organized as follows. Chapter 2 provides a background on the role of medium access control schemes as well as a detailed background on MIMO technology and Quality of Service in MAC schemes. In Chapter 3 MIMO-Aware MAC is proposed and results are detailed on the improvements in throughput and delay performance. Chapter 4 addresses the issue of wireless video transmission and proposes an application specific MAC scheme called Television TDMA to offer improvements for point-to-multipoint networks. Chapter 5 concludes this thesis and offers future research directions and suggestions.

Chapter 2

Background

The Internet has become a large part (and for many an essential part) of day-to-day life. It is also the largest public infrastructure in the world with an estimated 1.3 Billion users [9]. The continued operation of this advanced infrastructure is made possible through its hierarchial design. The TCP/IP model is a vital component in this design.

Figure 2.1 shows the design of the TCP/IP model of the Internet. This model is divided into four operational layers. Each layer is responsible for a certain aspect in the operation of the Internet.

The application layer (or the upper most layer) is utilized by users to send and receive network data. This layer is the initial source, and final destination of data. This may include various services, each with specific types of encoding, encryption and bandwidth needs. When data is transmitted over the Internet, a transmission is

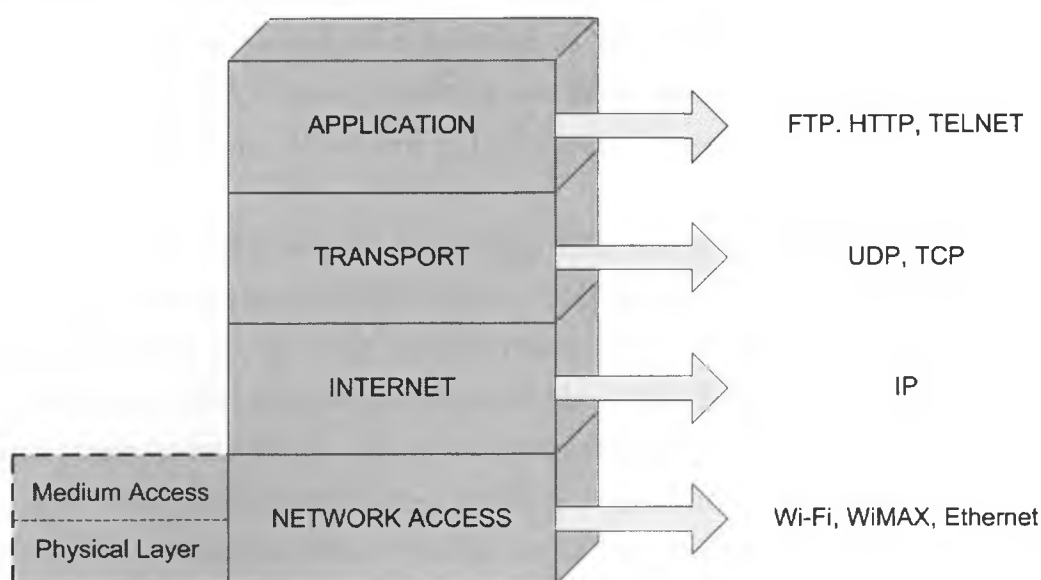

Figure 2.1: TCP/IP Internet Model

configured between two hosts with an end-to-end transport protocol; most commonly the Transport Control Protocol (TCP) or the User Datagram Protocol (UDP).

The transport layer manages these end-to-end protocols. This operation is transparent to the application layer. TCP is used for connection-oriented applications and provides reliability mechanisms such as packet reordering, error-control and flow-control while UDP is a connection-less protocol used to provide best-effort end-to-end transport.

The Internet layer is responsible for addressing and routing of packets across networks. The IP protocol at this layer is used to encapsulate data packets into IP datagrams which are suitable for delivery over any type of network supporting the IP protocol. This layer is also responsible for routing between networks to reach the destination.

The lowest layer of the TCP/IP model is the network access layer. This layer is responsible for the lower level data communication and is network specific. Both 802.11 and Ethernet are examples of protocols that operate at the network access layer. The network access layer is broken up into two sub-layers: the medium access layer; and the physical layer. The physical layer is responsible for physical transmission of 0's and 1's from one host to another. The medium access control layer (or MAC layer) is responsible for ensuring single-hop delivery of IP datagrams. When using a shared medium, it is possible that two or more stations may attempt to send data at once. This is known as a collision as no station will be able to recover the transmitted data. MAC layer protocols are responsible for proper detection and/or avoiding these collisions. The work in this thesis focuses on this layer of the TCP/IP model.

Wireless mediums present particular difficulty when designing MAC schemes. In wired connections, the medium is shared only between a limited number of stations physically attached to the wire. Furthermore the interference is limited by using a guided medium. The wireless medium on the other hand is shared amongst many users and prone to interference from a variety of sources. For these reasons, the MAC scheme must somehow control when stations communicate and how they handle interference. These responsibilities are similar to that of an airport air traffic controller. The controller is responsible for deciding when each plane must land and take off. However unlike the air traffic controller, many configurations of wireless networks do

not have a centralized architecture and must perform this task distributively. This is a major design challenge in the domain of MAC design.

Another design challenge is the inability of individual wireless stations to detect collisions. In the wired Ethernet protocol, any stations transmitting data can detect a collision on the network and immediately halt transmission; this is not possible in the wireless environment¹. To compound this problem, the wireless channel is highly susceptible to errors in comparison to a wired channel. The combination of these characteristics results in many design considerations and challenges for MAC protocols in wireless networks.

Currently, many wireless MAC protocols exist. The 802.11 MAC has largely been adopted and used as 802.11x based hardware is widely available in the market. However there is room for improvements. Going back to the air traffic controller and asking them “Is there a way to schedule landings and take-offs more efficiently?” or “Should international flight landings and take-offs take priority over domestic?” may turn up yes as an answer. Surprisingly, questions like these find duplicate meaning in MAC design.

An important goal in designing MAC protocols is to provide the highest system efficiency. Efficiency is a measure of the throughput that can be handled by the system. Multiple-Input, Multiple-Output antenna technology studied in recent years has shown that by using multiple antennas, coupled with complex signal processing, large scale increases in throughput can be achieved. MAC design must consider these throughput enhancements, and how to utilize them to provide the most efficient system.

Referring again to the question posed to the air traffic controller about what considerations should be made for various types of flights. In wireless networking, it is clear that there are several types of services (or “types of flights”) that must be serviced by wireless networking devices, each with specific needs. Today, networking devices provide support for telephone (voice), television (video), and other data services. Each service has needs that must be met in order to provide it. Voice services

¹The inability to detect collisions when they are occurring is because the close proximity of the transmitter and receiver hardware in a single station relative to other stations results in the station’s receiver only detecting its own transmission due to the relatively low received signal power from other ongoing transmissions. It is also not possible to detect collisions after a transmission has occurred (only packet loss) as it is not possible to differentiate between a packet lost due to channel errors/other interference or due to collision.

for example do not require a large amount of bandwidth, however are highly sensitive to variations in packet delay. Wireless video transmission is also of special consideration when analyzing the needs of these services as it requires both high data rates and low tolerance on its delay. Meeting these service requirements in WLANs is a large problem due to the major restrictions imposed by the wireless channel.

In the following Sections, background on these technologies is provided. Next, in Section 2.1, the benefits that are offered by MIMO systems for MAC layer improvement is presented. In Section 2.2, the challenges of wireless video transmission using MPEG-2 is addressed. Finally in Section 2.3, the evaluation platform used in this thesis, ns-2 [10] is described in some detail.

2.1 Multiple-Input Multiple-Output Antenna Systems

In recent years, Multiple-Input, Multiple-Output (MIMO) antenna systems have generated much attention from both sectors of research and industry. This technology offers the possibility of large scale increases in performance without the need for additional radio resources. Currently in the market there are a number of Wireless Local Area Networks (WLAN) devices that utilize multiple antennas to offer improvements in performance. The upcoming 802.11n standard [11] (currently still in draft) has attracted dramatic attention from the industry, and a number of consumer devices conforming to the current draft specifications are already available on retail shelves [12, 13].

2.1.1 Capacity Improvements offered by MIMO Channels

The improvements offered by MIMO can easily be observed by Shannon's Capacity Theorem. For a Single-Input, Single-Output (SISO) system, the channel capacity is well known to be [14]

$$\bar{C} = \log_2(1 + \rho) \quad \text{bps/Hz} \quad (2.1)$$

where ρ is the received Signal-to-Noise Ratio (SNR) and \bar{C} is the per unit bandwidth capacity.

For MIMO, the capacity expression is different. Firstly, for a frequency flat MIMO system that contains M_T transmitter antennas and M_R receiver antennas, the signal at each receiving antenna is given by [15]

$$r_i(t) = \sum_{j=0}^{M_T-1} s_j(t)h_{i,j}(t) + n_i(t) \quad j \in (0, M_T - 1), i \in (0, M_R - 1) \quad (2.2)$$

where $r_i(t)$ is the signal received at antenna i , $s_j(t)$ is the signal transmitted by antenna j , $n_i(t)$ is the additive noise and $h_{i,j}(t)$ is the transfer function between transmitter antenna j to receiver antenna i . Denoting $\mathbf{H}(t)$ as the $M_R \times M_T$ matrix with entries

$$\mathbf{H}(t) = \begin{bmatrix} h_{1,1}(t) & h_{1,2}(t) & \cdots & h_{1,M_T}(t) \\ h_{2,1}(t) & h_{2,2}(t) & & h_{2,M_T}(t) \\ \vdots & & \ddots & \vdots \\ h_{M_R,1}(t) & \cdots & \cdots & h_{M_R,M_T}(t) \end{bmatrix} \quad (2.3)$$

(2.2) can also be written in vector form

$$\mathbf{r}(t) = \mathbf{H}(t)\mathbf{s}(t) + \mathbf{n}(t) \quad (2.4)$$

where the boldface represents vector and matrix quantities.

With the above model, the capacity expression for a MIMO system becomes [15]

$$C(t) = \max_{\text{Tr}(\mathbf{R}_{\text{ss}})=M_T} \log_2 \det \left(\mathbf{I}_{M_R} + \frac{\rho}{M_T} \mathbf{H}(t)\mathbf{R}_{\text{ss}}\mathbf{H}(t)^\dagger \right) \text{ bps/Hz} \quad (2.5)$$

where \mathbf{R}_{ss} denotes the transmitted signal correlation matrix of $\mathbf{s}(t)$ ($\mathbf{R}_{\text{ss}} = E[\mathbf{s}(t)\mathbf{s}(t)^\dagger]$), the superscript \dagger denotes the complex conjugate transpose and ρ denotes the average SNR at any receiver antenna. In addition, the elements of $\mathbf{H}(t)$ are assumed normalized such that $E[|h_{i,j}|^2] = 1$. The maximum capacity is achieved by selecting the proper transmitted signal correlation matrix \mathbf{R}_{ss} subject to constraint on the input power (or $\text{Tr}(\mathbf{R}_{\text{ss}}) = M_T$). The above is often referred to the closed-loop capacity of a MIMO system as information regarding the time-varying quantity $\mathbf{H}(t)$ must be available at the transmitter to properly design $\mathbf{s}(t)$. As it is sometimes not possible to feedback in order to properly shape $\mathbf{s}(t)$, the transmitter will shape $\mathbf{s}(t)$ such that

$\mathbf{R}_{\text{SS}} = \mathbf{I}_{M_T}$. The respective capacity is termed as the open-loop capacity of a MIMO system and is given by [15]

$$C(t) = \log_2 \det \left(\mathbf{I}_{M_R} + \frac{\rho}{M_T} \mathbf{H}(t) \mathbf{H}(t)^\dagger \right) \quad \text{bps/Hz} \quad (2.6)$$

In (2.6) it can be seen that the capacity is time varying. Therefore a more meaningful value of the capacity is known as the ergodic capacity of the channel. This quantity is the ensemble average of capacity over the entire distribution of the MIMO channel matrix. Teletar showed [16] that the ergodic capacity of an independent and identically distributed (i.i.d) MIMO channel under Rayleigh Fading is given by

$$\bar{C} = \int_0^\infty \log_2 \left(1 + \frac{\rho}{M_T} \lambda \right) \sum_{k=0}^{m-1} \frac{k!}{(k+n-m)!} [L_k^{n-m}(\lambda)]^2 \lambda^{n-m} e^{-\lambda} d\lambda \quad (2.7)$$

where $m = \min(M_R, M_T)$, $n = \max(M_R, M_T)$ and $L_k^{n-m}(\lambda)$ is the associated Laguerre polynomial of order k given by

$$L_k^{n-m}(\lambda) = \frac{1}{k!} e^{\lambda} \lambda^{m-n} \frac{\partial^k}{\partial \lambda^k} \left(e^{-\lambda} \lambda^{n-m+k} \right) \quad (2.8)$$

Using numerical methods, (2.7) can easily be computed. Figure 2.2 shows the ergodic capacity improvements offered by use of various MIMO configurations. From this it is clear that MIMO systems offer large improvements in capacity versus single input single output systems.

2.1.2 MAC Improvement Using MIMO

The capacity previously derived demonstrates the ability of MIMO systems to offer dramatic improvements in network performance through an increase in channel capacity. For MAC layer designers, the benefit provides an increase in the physical layer datarate. The objective of MAC layer design in such a system is to optimize the use of the increased datarate to achieve the highest MAC layer serviceable datarate while providing fairness to all stations. The MAC layer serviceable datarate is defined as the rate at which upper layer data can be transmitted from one station to another over the link.

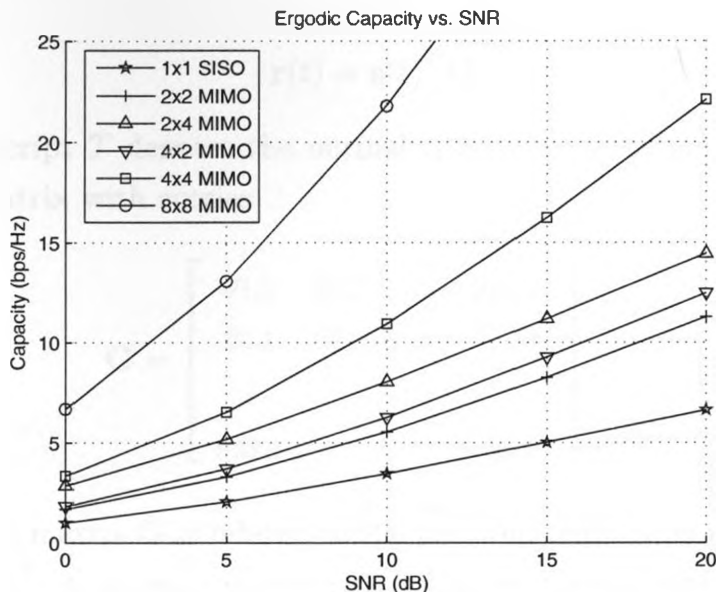

Figure 2.2: Ergodic Capacity vs SNR for Frequency Flat i.i.d. Channel Under Rayleigh Fading

MIMO systems can also be used to allow multiple simultaneous transmissions within a single contention region by use of beamforming or interference mitigation. This is accomplished with proper signal processing. These methods focus on increasing aggregate network throughput rather than increasing the data rate of individual stations. In this case, the MAC layer is a vital component to distributively schedule transmissions and disseminate information needed for all stations in the network to properly communicate; this is the concept applied in this work. This particular concept has been used in several recent works [17, 18].

Assuming that each station on a WLAN has an equal number of M antennas, and neglecting additive white noise, the received signal at antenna element j is found in a manner similar to (2.2) and is given by

$$r_j(t) = \sum_{i=0}^{M-1} s_i(t)g_{i,j}(t) \quad (2.9)$$

where here g_{ij} denotes the phase and amplitude distortion from the i^{th} transmitter antenna to the j^{th} receiving antenna. Assuming that the channel fading is slow and that the channel remains static over any given frame exchange, the above can then

be rewritten as

$$\mathbf{r}(t) = \mathbf{s}(t)^T \mathbf{G} \quad (2.10)$$

where the superscript T denotes the normal transpose operation and the matrix \mathbf{G} is the $M \times M$ matrix with entries

$$\mathbf{G} = \begin{bmatrix} g_{1,1} & g_{1,2} & \cdots & g_{1,M} \\ g_{2,1} & g_{2,2} & & g_{2,M} \\ \vdots & & \ddots & \vdots \\ g_{M,1} & \cdots & \cdots & g_{M,M} \end{bmatrix} \quad (2.11)$$

It is clear that the matrix \mathbf{G} is related to the previous defined matrix \mathbf{H} by $\mathbf{G} = \mathbf{H}^T$. Now defining $\mathbf{s}(t)^T = s(t)\mathbf{w}_n^\dagger$, where $s(t)$ is the equivalent SISO signal and \mathbf{w}_n is a vector of complex weights applied to this signal by transmitting station n , (2.10) becomes

$$\mathbf{r}(t) = s(t)\mathbf{w}_n^\dagger \mathbf{G}_{nm} \quad (2.12)$$

where the subscript \mathbf{G}_{nm} is used to specify the channel matrix between two stations n and m . Additionally, if this receiving station, m , applies a vector of weights on the received signal at each antenna \mathbf{w}_m , the post-processed received signal becomes

$$r(t) = s(t)\mathbf{w}_n^\dagger \mathbf{G}_{nm} \mathbf{w}_m \quad (2.13)$$

Where $r(t)$ is the SISO equivalent signal of interest.

From (2.13), the additional flexibility provided by the multiple antennas becomes clear. The scalar factor $\mathbf{w}_n^\dagger \mathbf{G}_{nm} \mathbf{w}_m$ denotes a complex gain product applied to the signal of interest. With proper channel knowledge G_{nm} at both stations m and n , these stations can selectively choose weight vectors \mathbf{w}_m and \mathbf{w}_n respectively to maximize reception or achieve signal cancelation (solving for weights such that $\mathbf{w}_n^\dagger \mathbf{G}_{nm} \mathbf{w}_m = 0$). The radio structure of a system using such a method is shown in Figure 2.3.

In Chapter 3, MIMO-Aware MAC will be presented. This proposed MAC protocol utilizes the above concepts to increase aggregate network throughput by use of these mechanisms.

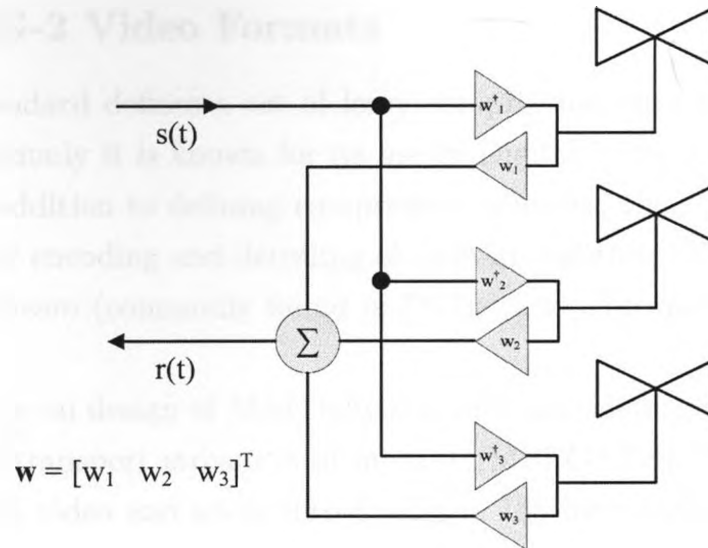

Figure 2.3: Radio Structure for Specified MIMO System

2.2 Wireless Video Transmission

The MAC is always required to distributively exchange information within a WLAN and schedule transmissions. More importantly, it is sometimes required to selectively distinguish priorities between different packets based on characteristics of those packets. There are two broad classes of traffic: time-sensitive and time-insensitive.

Time-insensitive traffic characterizes traffic that is still valuable if it arrives after a particular delay threshold. This does not mean that packet delay is acceptable or desirable, merely that it is better that the traffic arrives late than not at all.

Alternatively, time-sensitive traffic characterizes traffic streams that if arriving after a delay threshold, has little or no value. In this case, there is no distinction between the traffic arriving late and not at all. Video and voice traffic fall under this classification. Both of these classes of traffic are sensitive to packet delay and jitter.

Video traffic also requires large amounts of bandwidth in addition to requiring low delay. This presents many challenges to transmitting video streams over the wireless channel. For this reason, video traffic is special interest when designing MAC schemes that support service differentiation.

2.2.1 MPEG-2 Video Formats

The MPEG-2 standard defines a set of lossy compression algorithms for video and audio. Most commonly it is known for its use in Digital Video Discs (DVD) and in digital cable. In addition to defining compression schemes, the standard defines [19] system formats for encoding and decoding of data in real-time. These containers are called *Program Stream* (commonly found in DVDs) and *Transport Stream* (found in digital cable).

Since focus is on design of MAC schemes with consideration for wireless video transmission, the transport stream is of interest (MPEG2-TS). This stream encapsulates compressed video and audio into fixed-size 188 byte packet. The size of this packet is inefficient for wireless transmission due to the large amount of required overhead for each packet to be transmitted over the wireless channel². Additionally, the decoding standard for MPEG2-TS has a maximum allowed packet jitter of $25\mu\text{s}$. This small amount of jitter is achievable over wired connections (such as cable to the home), however is impractical for wireless video transmission when multiple users are sharing the same medium. In [20] the authors proposed aggregating several MPEG2-TS packets into a larger payload for wireless transmission to solve the problem of the large required overhead. In addition, packets were encoded in such a way that they could properly be decoded at the receiver, however the proposed system is for a single video stream and does not consider the effects of a multiuser channel. For this reason, it is not feasible to properly transmit MPEG2-TS encapsulated video over the wireless medium. Alternatively the proposed system in Figure 2.4 could be used for providing wireless television services from existing digital video broadcast (MPEG2-TS) streams.

In this proposed system, the individual MPEG2-TS constant bitrate streams are decoded and re-encoded as a variable bitrate (VBR) MPEG-2 stream. The output stream is broken into packets and enqueued in a video transmit buffer. In addition, other data services (such as voice and best-effort data) are forwarded by the cable hub to the subscriber. Finally, a buffer at the receiver is used to sufficiently buffer video data for reconstruction of frames, as well as to ensure a reasonable viewer experience.

²Over 802.11a with a PHY datarate of 54Mbps, almost 47% of the channel time is required for physical layer overhead. See Appendix A for calculations.

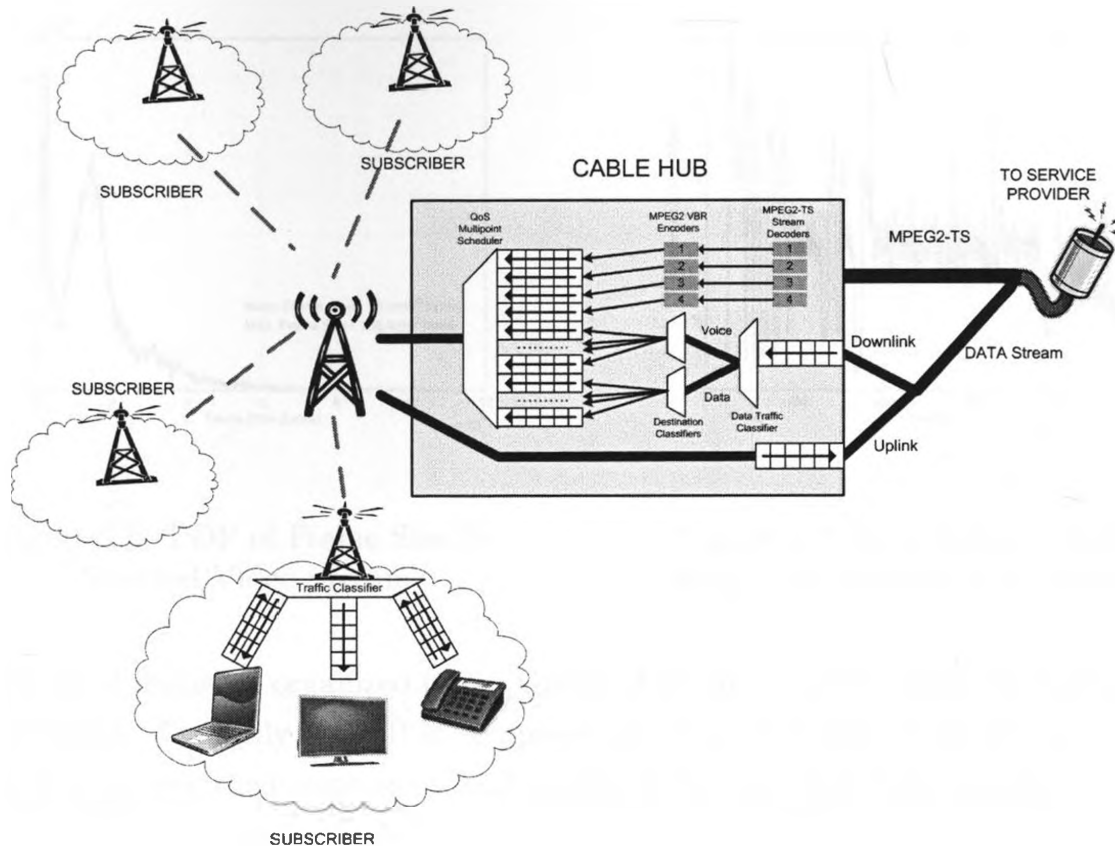

Figure 2.4: Proposed Point-to-Multipoint Wireless Video System

2.2.2 MPEG-2 Traffic Characteristics

MPEG-2 encoding uses three unique types of frames that raw video frames can be compressed into. These are:

- *Intra-Coded (I) Frames*: I-Frames contain an entire frame of data. This is the compressed equivalent of the raw video frames.
- *Predictive-Coded (P) Frames*: P-Frames reference data on a previous frame and only contain the changes in video data. This is advantageous as it utilizes redundancy in video data to dramatically reduce the size of video frames that are encoded as P-Frames.
- *Bidirectionally-Predictive-Coded (B) Frames*: B-Frames are similar to P-Frames, however they offer the opportunity of higher compression as they can reference previous and future frames.

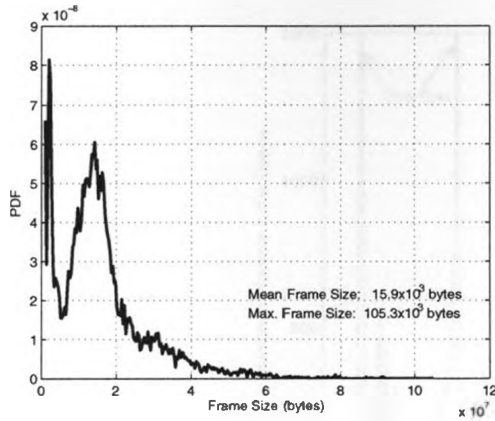

Figure 2.5: PDF of Frame Size for Selected Video Stream

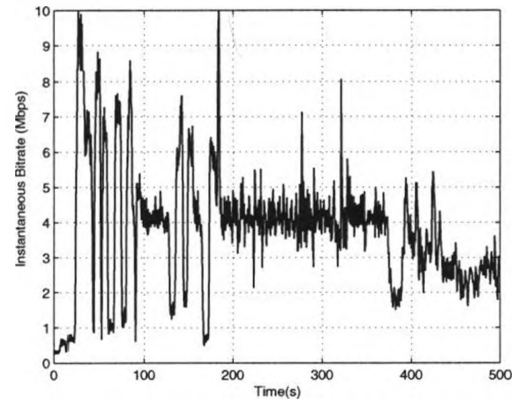

Figure 2.6: Instantaneous Video Bitrate for Selected Video Stream

Each set of frames is organized into a Group of Pictures (GOP), each beginning with an I-Frame. Typically a GOP is composed of 12 or 15 frames, however this can be specified to vary the compression and quality of the encoded video sequence.

As the compression results in a variable bit rate video, it is important to first observe the fluctuations associated with the instantaneous video bitrate. For this, the first 500 seconds of the film 'Blackhawk Down' was encoded using the ffmpeg [21] encoder with parameters shown in Table 2.1. In Figure 2.5, the probability density function (PDF) of the encoded video frame sizes is shown³. From this it can be seen

Table 2.1: Video Encoding Target Parameters

Parameter	Value
Target Bitrate	4Mbps
Resolution	720×480 pixels
Frame Rate	30fps
Video Length	500s
Audio Bitrate	128kbps (stereo)

that the mean frame size is 15.9×10^3 bytes. Such frame sizes are too large to be transmitted error free over the wireless channel as larger packets are more suscep-

³This includes both I and P Frames (no B-Frames)

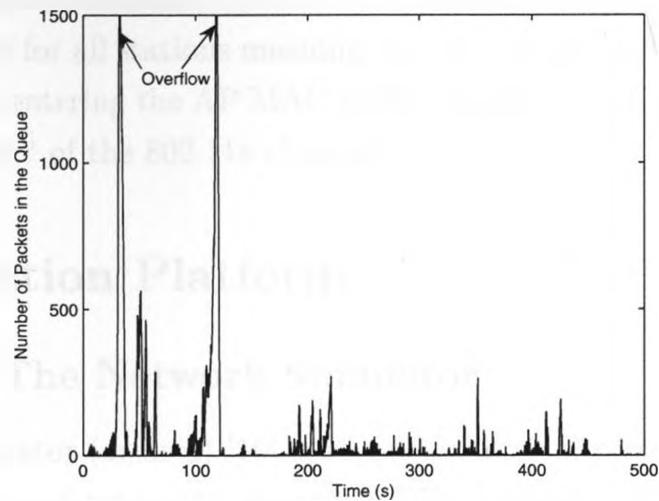

Figure 2.7: Access Point Queue Evolution for Access Point Serving 4 Stations

tible to bit errors. For this reason fragmentation of the frames must be performed. Suppose the maximum fragment size that can be transmitted on the wireless channel is 1280 bytes, then the average number of packets to transmit a frame is given as $\lceil 15874/1280 \rceil = 13$. Where $\lceil \cdot \rceil$ denotes rounding up to the nearest integer multiple. With this same fragmentation threshold, the largest frame of 105.3×10^3 bytes will fragment into 83 packets. For finite buffer systems, queuing all packets at a given time may result in buffer overflow. This must be taken into account when enqueueing video frames from upper layers. Figure 2.6 shows the instantaneous bitrate versus time for 500s of encoded video. From this, the large variations in instantaneous bitrate is clearly shown. Although the average bitrate is less than the target (approximately 3.81Mbps⁴), certain regions approach nearly 10Mbps. This must also be taken account for wireless transmission as the physical datarate of the channel is fixed for a given physical layer modulation scheme.

To understand the effect of the variable bitrate video on the network buffer, a simple 5 station network is setup in ns-2 [10]. An access point (AP) is configured to transmit the same video stream from Figure 2.6 to the other four stations over 802.11a using the 802.11 basic access mechanism. The evolution of the AP buffer over time is shown in Figure 2.7. It can be seen that in regions of high bitrate, the buffer occupancy increases as the AP cannot service the packets at that rate. This issue is

⁴1Mbps= 1×10^6 bits per second(bps)

further compounded in this case as the transmitted video stream contains the same high bitrate regions for all stations meaning that at certain time instances, more than 40Mbps of video is entering the AP MAC buffer, which is much higher than the MAC serviceable datarate⁵ of the 802.11a channel.

2.3 Evaluation Platform

2.3.1 ns-2 - The Network Simulator

The Network Simulator (or ns-2) [10] is an open-source discrete events simulator for computer simulation of network performance. Unlike traditional network simulation tools, its versatility and robustness provide the ideal simulation environment. It has become a common research tool as it promotes ease of integration of custom protocols and allows researchers to easily monitor the performance of their implemented protocols.

The software was originally designed at UC Berkeley [10]. CMU Monarch later developed wireless extensions to the software [22]. Currently, the software is a collaboration of a number of institutes and other collaborators with the continued addition of new network protocols and network devices.

In this thesis work, ns-2 is used heavily for evaluation of proposed protocols. In ns-2, each mobile node is built using a layered model. In this fashion, it facilitates the verification and evaluation of new protocols by modifying only the layer of interest. In this work, modifications are made to the MAC layer modules, while maintaining other modules intact.

The structure of a mobile node in ns-2 can be seen in Figure 2.8. A brief description of each model is given below.

2.3.1.1 PHY - Physical Propagation Model

In ns-2, the physical layer mechanism is employed when a station receives a packet. When a packet is released from the MAC layer of a transmitting node, the packet is copied to the physical layer of all mobile nodes. Each mobile node determines

⁵The MAC serviceable datarate is the rate at which upper layers can transmit data over the link.

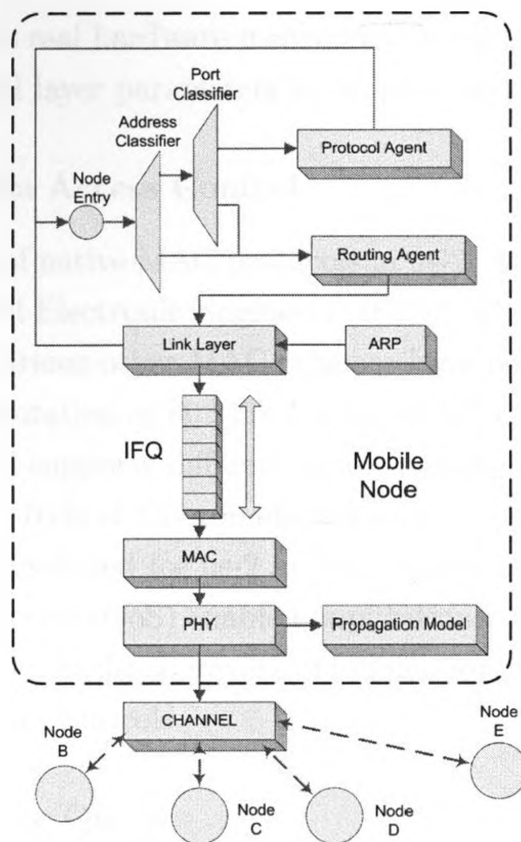

Figure 2.8: Mobile Node Model in ns-2

accordingly whether the packet is received successfully by its physical layer. This decision is based on

- The error model employed
- The physical propagation model employed
- Distance between the two mobile stations
- Receiving threshold levels of individual mobile nodes

There are several error and propagation models natively in the ns-2 package. Uniform error rates can be set, in addition both Free Space propagation and Two-Ray Ground models are available. Various other extensions exist such as the Ricean Fading model from [23]. This models a time-correlated received envelope in ns-2. Receiving thresholds for the mobile node can also be configured, however a default set of parameters is

commonly used based on real hardware measurements. It is the responsibility of the user to configure physical layer parameters to properly model real-world scenarios.

2.3.1.2 MAC - Media Access Control

There are large number of native MAC protocols in ns-2. Most commonly used is the Institute of Electrical and Electronic Engineers (IEEE) 802.11 Distributed Coordination Function (DCF). Various other MAC schemes have been added by the research community. An implementation of 802.11e Enhanced DCF has been created by [24]. This distributed protocol supports different access parameters for four different traffic classes. The 802.11e Hybrid Coordination Function Controlled Channel Access (HCCA) has also been developed for ns-2 in [25]. This is a centralized MAC scheme to support Quality of Service (QoS) enabled applications.

The major work in this thesis involves modification of this layer to implement and evaluate the designed protocols.

2.3.1.3 IFQ - Interface Queue

The Interface Queue sub-layer in ns-2 provides the finite length queue of the link layer to buffer packets to be processed by the MAC. When the MAC is ready to accept a new packet for transmission, it will signal the link layer to advance the buffer. The queue has priority capabilities, and gives priority to routing protocol packets. Additionally, the 802.11e MAC layer utilizes a modified queue interface to partition the queue into multiple access categories to provide QoS.

2.3.1.4 Link Layer

The link layer in ns-2 manages traffic flow of the medium. It also provides translation capabilities to allow for the interface of various MAC protocols with standard upper layers. The wireless model in ns-2 utilizes a similar link layer as wired nodes, however there is an address resolution protocol (ARP) component. The link layer contains a query interface to the ARP.

2.3.1.5 ARP - Address Resolution Protocol

The ARP module in ns-2 simulates ARP. The purpose of ARP is to resolve the MAC address from the Internet Protocol (IP) address of a target node. The procedure involves sending an ARP request broadcast to all nodes in the network. The destination node will respond to the ARP reply with its corresponding MAC address.

2.3.1.6 Upper Layers: Agent and Routing

Upper layers of the mobile node (as in Figure 2.8) are independent of the mobile implementation. The routing agent controls the routing mechanism in the network. This is not specific to mobile nodes, there are however several mobile routing protocols built-in such as:

- Dynamic Source Routing
- Destination-Sequence Distance Vector
- Ad hoc On-Demand Distance Vector
- Temporally-Ordered Routing Algorithm
- Disable Multi-hop Routing (Dumb Agent)

As in this thesis the focus is on single-hop WLANs, the Dumb Agent routing protocol is used.

The agent layer is where all traffic generation occurs. In terms of ns-2, a transport source agent such as User Datagram Protocol (UDP) or the Transport Control Protocol (TCP) is attached to the traffic generating node, while a sink agent is attached to the receiving node (a null agent for UDP as no acknowledgements are required). A traffic agent is attached to the transport agent. In ns-2 there are many included traffic generation agents such as exponential and constant bit rate (CBR). All parameters associated with the traffic (packet size, data rate, etc.) are configurable in the simulation parameters.

2.3.1.7 Evalvid Framework

In the study of video performance, this thesis employs use of a customized version of the evalvid framework [26]. The evalvid package allows evaluation of real-time video using the ns-2 simulator. The existing version of evalvid allows creation of video trace files to model real-time MPEG-4 traffic from MPEG-4 video sources.

As this thesis utilizes MPEG-2 as a traffic source, an MPEG-2 trace file generator was written to supply a realistic MPEG-2 traffic model. The software allows tracefile generation from any video format as long as the proper codec is installed on the coding system. The software takes the following arguments as an input:

- Input video file (any supported format)
- Target bitrate
- Resolution
- Frames Per Second (fps)
- Length of Video Tracefile to generate (in seconds); and
- Maximum packet size

The software will output an evalvid compatible tracefile. The encoder only utilizes I and P frame types with 15 frames in a GOP with the sequence IPPPPPPPPPPPPPP. B-Frames are not used as they require knowledge of future frames which is not suitable for real-time transmission. Any frames larger than the maximum packet size are fragmented and scheduled equidistant between the two scheduled frames.

For example, if x_n is the time that frame n is scheduled to be transmitted before fragmentation occurs, κ_n is the number of fragments of frame n and r is the inter-frame spacing in seconds. Then the scheduled time of the fragmented frame is given by

$$x_{n,k} = x_n + (k - 1)r, \quad k = 1, 2, \dots, \kappa_n \quad (2.14)$$

Where $x_{n,k}$ is the scheduled time of the k^{th} fragment of frame n .

In addition to the tracefile generation, custom analysis scripts are used to analyze frame error rates, delay and jitter.

In the following Chapters, all these concepts will be utilized for MAC layer design. Chapter 3 proposes a novel MAC scheme that utilizes the described MIMO

systems for scheduling of simultaneous transmissions. In Chapter 4, a new point-to-multipoint MAC scheme is introduced that addresses the challenges presented with wireless video transmission.

Chapter 3

MIMO-Aware Media Access Control

3.1 Literature Review and Motivation

3.1.1 Existing MIMO MAC Protocols

As discussed in Chapter 2, it is possible to utilize MIMO to achieve improvements in aggregate network throughput by allowing simultaneous communication within a single collision domain. There have recently been several proposed protocols which utilize this methodology in the literature.

3.1.1.1 MIMA-MAC

Mitigating interference using multiple antennas MAC (MIMA-MAC) [27] allows multiple stations to communicate within a contention region by utilizing zero-forcing MIMO receivers in each wireless station. The number of simultaneous transmissions available in MIMA-MAC is equal to the number of antennas per station. In MIMA-MAC, the authors have proposed a fixed size MIMA-MAC frame that is divided into a contention period and a contention-free period. The contention period allows wireless stations to compete for channel access during the contention-free period. The contention period is divided into slots for multiple contentions. The order of channel acquisition during the contention period determines the order of transmission of training and acknowledgment packets in the contention-free period by the wireless stations.

In the contention-free period, stations first send training sequences for channel estimation. As mentioned, the order in which stations acquired the channel during the contention slots defines the order of the training sequences. Following these sequences, all transmitting stations will send data packets simultaneously. Receivers decode data from their respective transmitters using the channel information resolved from the training sequences. Following data transmission, acknowledgement packets

are also sent by the receivers to confirm successful transmission of the data packets. These are transmitted in the same order as the training sequences. The authors of MIMA-MAC also proposed MIMA-MAC with antenna selection [28]. This scheme is similar to MIMA-MAC, however allows the receiving station to feedback which transmitter antenna achieves the highest post-processing received SNR.

The main disadvantage of both MIMA-MAC and MIMA-MAC/AS is the requirement of a fixed frame size which is not suitable for networks with varying packet sizes and therefore most WLAN applications.

3.1.1.2 NULLHOC

NULLHOC [18] schedules simultaneous transmissions by applying gains to each antenna element at both transmitting and receiving stations. This method is discussed in some detail in Section 2.1.2. In this protocol, by designing antenna weights appropriately, any station may listen or ignore (i.e., tune in or tune out) any other station. This allows multiple packets to be sent over the channel simultaneously. In this protocol, the channel is divided into two sub-channels namely data and control sub-channels. The control sub-channel is used to monitor traffic levels on the network while the data sub-channel is used for data transmission. The NULLHOC protocol utilizes a five packet exchange sequence (RTS/CTS/DS/DATA/ACK). Request-To-Send and Clear-To-Send (RTS/CTS) packets are sent on the control channel. If these stations can successfully exchange these packets, then the transmitting station follows with a Data-Send (DS) packet on the data sub-channel to reserve the channel resource. This is followed by the data packet transmission by the transmitting station and positive acknowledgement packet by the receiving station on the data sub-channel. By exchanging antenna weights in the control channel, NULLHOC supports multiple transmissions.

The major limitation in NULLHOC is the need for channel partitioning. This protocol imposes hardware complexity restrictions. Additionally channel estimation must be performed on the control sub-channel, while the channel information required for tuning antenna weights should be found for the data sub-channel. Finally, the operation of NULLHOC is also not compatible with IEEE 802.11 standard.

3.1.1.3 SPACE-MAC

SPACE-MAC [17] also utilizes antenna weights to schedule simultaneous transmissions on a single collision domain. However in SPACE-MAC, a wireless station uses the same adjusted weights for both transmission and reception in a manner that allows it to comply with the 802.11 standard. As in NULLHOC, antenna weights are exchanged via control packets (RTS and CTS). Stations should always transmit packets (including control packets) without interfering with existing active transmissions. In SPACE-MAC, the first station that gains access to the channel determines the silence period. All other stations must remain idle following their transmission until the completion of this silence period. In SPACE-MAC, the silence period is required because any station currently involved in transmission is unaware of any other transmissions that began after it began transmitting. Additionally, any station that wishes to transmit must not interfere with this ongoing transmission as well as not transmit if it cannot complete its entire packet exchange sequence before the end of the silence period.

The performance of the SPACE-MAC protocol is heavily dependant on the length of the silence period. The optimal length of silence period varies with the network size and the traffic conditions. This is a major limitation with SPACE-MAC as suboptimal silence periods drastically reduce the maximum achievable throughput for a particular network scenario.

3.1.2 Motivation

Though all the mentioned MAC protocols in the previous section schedule simultaneous transmissions over a single collision domain, only SPACE-MAC is compatible with the IEEE 802.11 standard. After examining the maximum achievable throughput in SPACE-MAC, it is clear that this is reliant on the selection of a proper silence period. Furthermore, this optimal silence period varies with different network scenarios and traffic conditions. For example, consider a network with 20 wireless stations located closely to each other and share a single collision domain. All these stations are identical and use the SPACE-MAC protocol for scheduling their transmissions. It is assumed that MIMO physical layer offers 1 Mbps datarate to the MAC layer. With this assumption, the throughput performance of SPACE-MAC for two different packet sizes (512 and 1024 bytes) is shown in Figure 3.1. The length of the silence

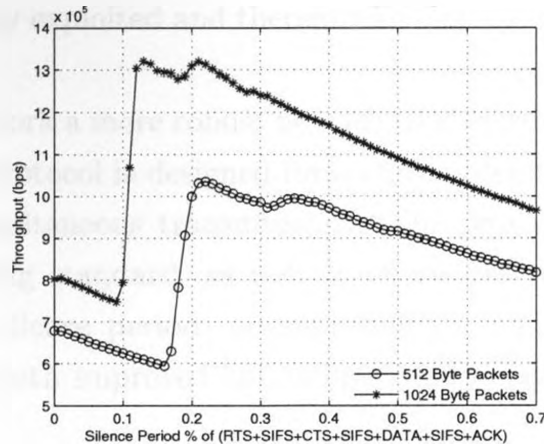

Figure 3.1: Throughput vs. Silence Period - 20 Stations - 1Mbps

period is varied to observe the maximal achievable throughput in SPACE-MAC. The scheme achieves roughly up to a maximum of 1.3 Mbps overall throughput when the packet size is 1024 bytes. This maximum throughput is achieved only for a particular length of silence period which is optimal for this scenario. For any other silence periods, the throughput is reduced considerably. The same phenomenon can be observed when the packet size is changed to 512 bytes. With 512 byte packets, SPACE-MAC barely achieves 1 Mbps throughput for optimal silence periods. Therefore, it is quite obvious that the throughput performance of SPACE-MAC is highly dependant on the length of silence period.

Furthermore, the optimal silence period for SPACE-MAC also depends on the contention level and dynamics of the network traffic. This creates restrictions for designers in choosing an optimal silence period for nondeterministic network scenarios. As the dependency of SPACE-MAC on silence period is undesirable, more robust MAC protocols for MIMO are essential.

After examining the impact of an increased number of antennas on weighted MIMO MAC protocols (such as NULLHOC and SPACE-MAC), it is clear that these protocols reach saturation quickly in terms of the gain associated with an increasing number of antennas. In order to provide proper antenna spacing, the maximum number of antennas that can be supported in consumer devices such as laptops and PDAs is also limited. Furthermore, in many practical networking scenarios, the number of stations within a given network are limited so that any additional transmission re-

sources may not be fully exploited and therefore reduce the requirement of additional antennas.

As such, in this work a more robust new MIMO-aware MAC (MA-MAC) protocol is proposed. This protocol is designed for a three antenna element MIMO system and allows up to two simultaneous transmissions. The protocol also offers both compatibility to the existing standard, as well as eliminates requirements of empirical quantities (such as a silence period) on achieving its maximal performance. This new scheme provides both improved throughput and delay performance in WLAN applications.

3.2 MA-MAC Protocol

The proposed MIMO-aware MAC (MA-MAC) scheme in this section utilizes the beamforming feature in MIMO to schedule multiple transmissions on the wireless channel. Wireless stations adjust their antenna weights to selectively tune in or tune out a particular transmission as governed by MA-MAC. The proposed scheme uses a three element antenna array as MIMO physical layer to schedule up to two simultaneous transmissions in a single collision domain. This is achieved through a newly proposed MAC decision process along with intelligent packet fragmentation. MA-MAC utilizes the request-to-send/clear-to-send (RTS/CTS) access mechanism used in the IEEE 802.11 distributed coordination function (DCF). The antenna weights are conveyed through RTS and CTS packets. The following subsections present detailed description of MA-MAC.

3.2.1 Weight Adjustment Procedure

As discussed in Chapter 2, MIMO antenna systems can be used to selectively tune in or tune out a particular transmission from a station via signal processing by properly adjusting antenna weights. A particular station transmitting on the WLAN can therefore transmit when the wireless channel is absolutely idle or when a transmission is already in progress. As such a given transmitter-receiver pair faces interference from other transmitter-receiver pairs. In order to limit the interference (for proper data transmission on the network), only a limited number of simultaneous transmissions are allowed at any particular time instance in a WLAN subject to the maximum number

of degrees of freedom (which is equal to the number of antenna elements). Therefore, an M element MIMO system on each wireless station allows for up to $\frac{M+1}{2}$ simultaneous transmissions in a single collision domain. This is necessary because each existing transmitter-receiver pair consumes two degrees of freedom. Since MA-MAC is designed for systems with a three element antenna array, it is possible to achieve a maximum of two simultaneous transmissions within a single collision domain. For transmission on wireless channel, the stations adjust their weights during one of the following two situations: 1) when the channel is absolutely idle, and 2) when the channel has existing transmissions.

3.2.1.1 Idle Channel Weight Adjustment

Wireless stations that initiate transmission when the channel is absolutely idle have the flexibility to adjust their antenna weights to obtain the best possible signal-to-interference-noise ratio (SINR). For this a transmitting wireless station uses default antenna weights to initiate its transmission. The intended receiver station then adjusts its antenna weights to maximize the SINR, which means

$$\max_{\text{norm}(\mathbf{w}_R)=1} \left(\mathbf{w}_T^\dagger \mathbf{G}_{TR} \mathbf{w}_R \right) \quad (3.1)$$

It is clear that with the knowledge of \mathbf{G}_{TR} and \mathbf{w}_T , \mathbf{w}_R should be

$$\mathbf{w}_R = \left\| (\mathbf{w}_T^\dagger \mathbf{G}_{TR})^\dagger \right\| \quad (3.2)$$

Where $\|\mathbf{x}\|$ denotes the normalization operation (i.e., $\|\mathbf{x}\| = \frac{\mathbf{x}}{\text{norm}(\mathbf{x})}$).

The weight adjustment in this scenario can be demonstrated using the simple ad-hoc network scenario shown in Figure 3.2. The ad-hoc network has contains 6 stations; Stations A through F, which are all within radio range of all the other stations and have the radio structure found in Figure 2.3. First, suppose that the channel is idle and Station A is the first station to access the channel. Assuming that Station B is the intended receiver for Station A, Station B adjusts its antenna array element weights using (3.2). All other stations on the channel tune out the transmissions from both Station A and Station B by nulling:

$$\mathbf{w}_A^\dagger \mathbf{G}_{AX} \mathbf{w}_X = 0 \text{ and } \mathbf{w}_X^\dagger \mathbf{G}_{XB} \mathbf{w}_B = 0 \quad (3.3)$$

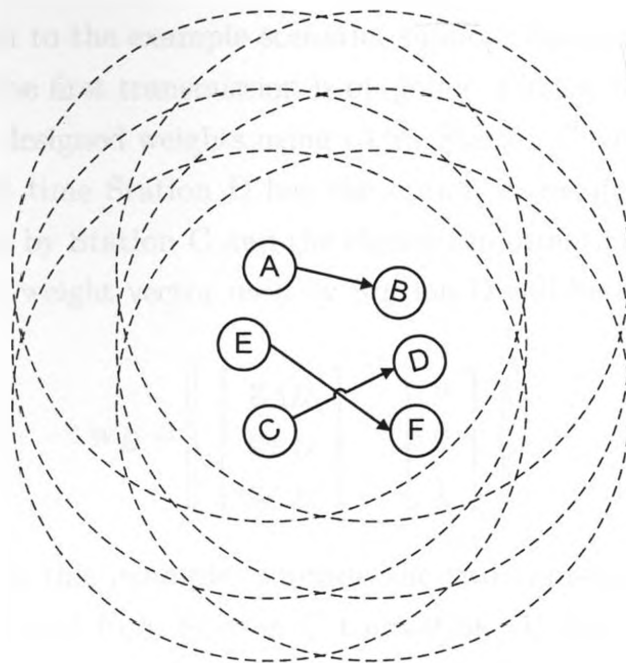

Figure 3.2: Ad hoc network scenario

For this, knowledge of the return channel is required. In this work it is assumed that the MIMO channels are reciprocal (implying $\mathbf{G}_{xy} = \mathbf{G}_{yx}^\dagger$).

3.2.1.2 Busy Channel Weight Adjustment

For other wireless stations on the channel to communicate during the ongoing transmission, they must null the existing transmission using (3.3) to not interfere with the first transmission. First defining $\mathbf{g}_{xy} = \mathbf{w}_x^\dagger \mathbf{G}_{xy}$, the above equation can be expressed as

$$\mathbf{g}_{AX} \mathbf{w}_X = 0 \text{ and } \mathbf{g}_{BX} \mathbf{w}_X = 0 \quad (3.4)$$

for any other Station in the network (e.g., Station X). Since at this point in time Station X is unaware of its intended receiver or transmitter, it would assume that the effective channel from an unknown Station Y is given by $\mathbf{g}_{YX} = [1 \ 1 \ 1]$. The weight vector design for Station X becomes

$$\mathbf{w}_X = \left\| \left[\begin{array}{c} \mathbf{g}_{AX} \\ \mathbf{g}_{BX} \\ \mathbf{g}_{YX} \end{array} \right]^{-1} \left[\begin{array}{c} 0 \\ 0 \\ 1 \end{array} \right] \right\| \quad (3.5)$$

Referring again to the example scenario, suppose Station C wishes to transmit to Station D while the first transmission is on-going. Firstly, both Stations C and D would have already designed weights using (3.5). Station C will utilize these weights to transmit. At this time Station D has the option to readjust its weights subject to the weights in use by Station C and the channel information from Station C (i.e., \mathbf{g}_{CD}). The resulting weight vector used by Station D will become

$$\mathbf{w}_D = \left\| \left[\begin{array}{c} \mathbf{g}_{AD} \\ \mathbf{g}_{BD} \\ \mathbf{g}_{CD} \end{array} \right]^{-1} \left[\begin{array}{c} 0 \\ 0 \\ 1 \end{array} \right] \right\| \quad (3.6)$$

To demonstrate this example, suppose the two transmissions (i.e., from Station A to Station B and from Station C to Station D) are on-going using weight vectors \mathbf{w}_A through \mathbf{w}_D respectively. Station B will receive the following signal

$$r_B(t) = (s_A(t)\mathbf{w}_A^\dagger \mathbf{G}_{AB} + s_C(t)\mathbf{w}_C^\dagger \mathbf{G}_{CB})\mathbf{w}_B \quad (3.7)$$

$$= s_A(t)\mathbf{w}_A^\dagger \mathbf{G}_{AB}\mathbf{w}_B + s_C(t)\underbrace{\mathbf{w}_C^\dagger \mathbf{G}_{CB}\mathbf{w}_B}_0 \quad (3.8)$$

$$= s_A(t)\mathbf{w}_A^\dagger \mathbf{G}_{AB}\mathbf{w}_B \quad (3.9)$$

The above can also be shown for all pairs involving Stations A through D due to the design of their respective weights.

3.2.2 RTS/CTS Control Packet Format

For stations to selectively tune in or tune out a particular transmission, they have to be aware of the antenna weights that are in use by transmitting stations. This requires a mechanism for conveying the antenna weights to all neighboring stations. The 802.11 MAC protocol specifies an optional Request-to-Send/Clear-to-Send (RTS/CTS) access mechanism [1]. In MA-MAC, the RTS/CTS mechanism is mandatory as RTS and CTS control packets are used to convey antenna weight information. The proposed format for RTS and CTS control packets is shown in Figure 3.3. An additional 12 byte field is inserted in the payload of the RTS and CTS packets that stores three antenna element weights currently in use. Each weight is represented as a 32-bit complex number (16 bits to denote the real and imaginary components respectively).

RTS and CTS packets are also used to perform channel estimation using pilot symbols. It is assumed that these pilot symbols are embedded in the physical (PHY) preamble and in this work that there is no error in channel estimation.

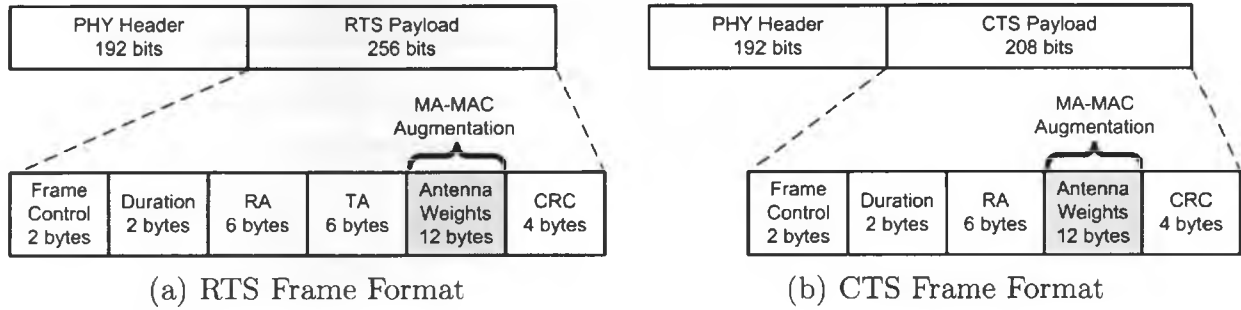

Figure 3.3: Access Control Packets

3.2.3 Protocol Operation

The MA-MAC protocol allows up to two simultaneous transmissions to proceed in a single collision domain. Wireless stations in MA-MAC adjust their antenna weights and take appropriate scheduling decisions depending on the channel status, i.e., depending on whether the channel is absolutely idle or a transmission is already taking place on the channel. The network scenario given in Figure 3.2 will be used again for the description of the proposed MA-MAC scheme.

Initially, all stations observe the channel for a certain time which is the sum of partial weight sensing period and distributed inter frame space ($WSP_{partial} + DIFS$). The time $WSP_{partial}$ is a small period for which a station can be assured that there are no active transmissions on the channel and is equal to the sum of short inter frame spacing and the amount of time to send a special SP_{src} packet ($SIFS + SP_{src}$), while SIFS and DIFS are durations defined in the 802.11 DCF specifications. If the channel is found idle during this time, stations begin decrementing their backoff counters. When a station's backoff counter expires, it sends an RTS packet containing its currently used antenna weights. This is shown in Figure 3.4, where Station A sends an RTS packet to Station B. Upon reception of RTS, all neighboring stations which are not the intended receivers (i.e., Stations C, D, E and F) will pause their backoff counters and store the duration information of the transmission as well as the

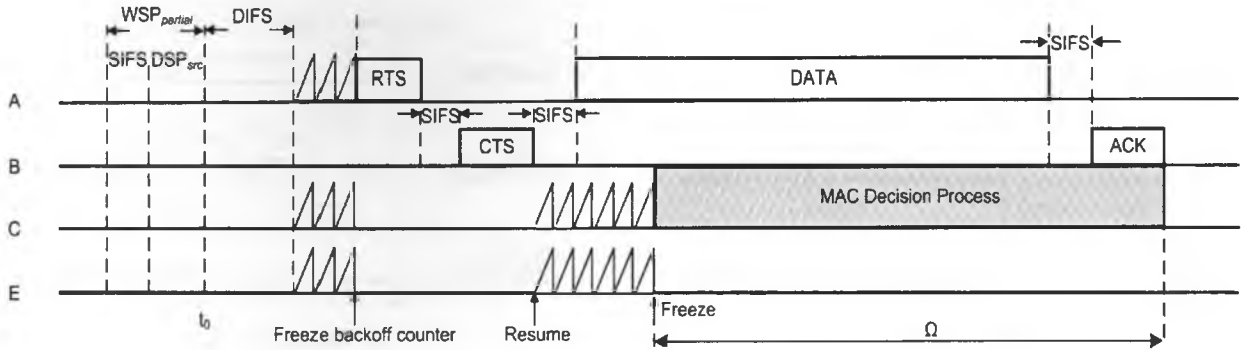

Figure 3.4: MA-MAC scheme timing diagram.

antenna weights in use by Station A. The intended destination station (Station B), receives the RTS packet and adjusts its antenna weights to maximize the received signal SINR (as described in Section 3.2.1). In addition, Station B responds with a CTS packet containing weight information. Stations A and B will now become the primary stations as they have successfully exchanged RTS and CTS packets between them. Station A will now proceed with DATA packet transmission to Station B which will in turn respond with a positive acknowledgement (ACK) packet.

The primary stations transmit using the packet exchange sequence similar to the RTS/CTS scheme in DCF. When the packet exchange sequence between the primary stations (e.g., Stations A and B) is completed, they select a new weight vector and observe the channel for a certain time equal to $WSP_{partial}$. If the channel is found idle during this time, the stations continue to observe the channel to be idle for additional DIFS time before resuming the backoff process.

Once a primary transmission has been established, any other station may compete for the remaining channel resource. After the primary transmission is established and other stations resume their backoff process (as shown in Figure 3.4), assume that Station C is the next station to complete its backoff process. It will initiate a secondary transmission without interfering with the ongoing primary transmission provided it is efficient to do so. The station performs a proper MAC decision to determine what actions must be taken based on the residual time remaining in the primary transmission (denoted Ω in Figure 3.4). Assuming that Station C is successful in establishing transmission, the time taken to complete a full frame exchange is

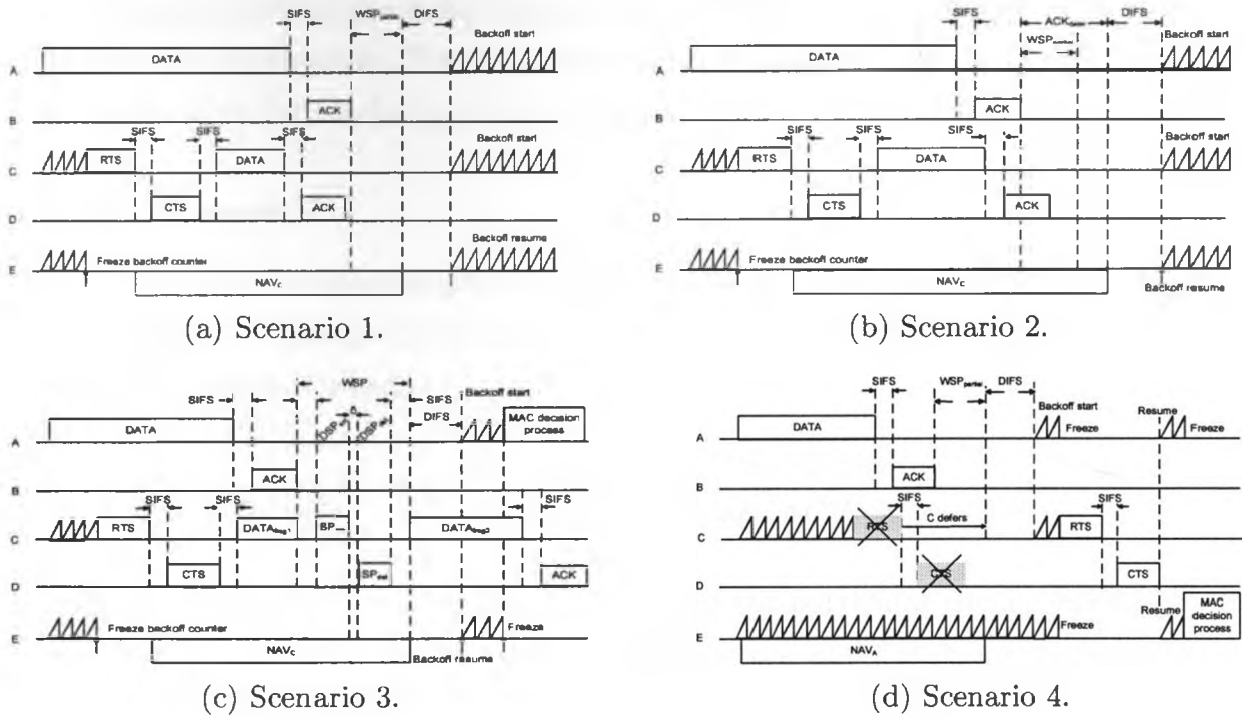

Figure 3.5: Timing diagram of MAC decision process for secondary stations.

given by

$$RTS + SIFS + \delta + CTS + SIFS + \delta + DATA + SIFS + \delta + ACK$$

where δ is the propagation delay experienced. There are four cases formed by decision thresholds that the secondary station (Station C) can encounter based on the value of the residual time Ω if it were to begin a transmission; these are:

1. A secondary station will complete its full transmission before the primary finishes.
2. The secondary station will be transmitting an ACK packet when the primary transmission finishes.
3. The secondary station will be transmitting its DATA packet when the primary transmission finishes.
4. The secondary station will be still performing a control packet exchange (RTS/CTS) when the primary transmission finishes.

For each of the above cases, the secondary station makes a proper MAC decision to govern its transmission. For all cases the timing diagrams are shown in Figure 3.5. The details of operation for each case is given below.

3.2.3.1 Scenario 1

When a secondary station determines that the residual time in the primary transmission is sufficient to complete the entire packet exchange, the station proceeds with its transmission. This is when

$$\Omega > \begin{aligned} & \text{RTS+SIFS}+\delta+\text{CTS+SIFS}+\delta \\ & \quad +\text{DATA+SIFS}+\delta+\text{ACK}+\delta \end{aligned} \quad (3.10)$$

where all quantities define the time taken to send the particular packet, SIFS is short inter-frame spacing defined by the 802.11 specifications and δ is the propagation delay incurred. DATA denotes the data packet transmission time of a secondary station wishing to transmit.

In this case Station C proceeds with transmission using antenna weights designed not to interfere with the primary stations (Station A and Station B) as shown in Figure 3.5(a). As previously mentioned, these weights are included in the RTS packets in order to disseminate this information to all other stations. Upon reception of this transmission, the intended receiver (i.e., Station D) readjusts its antenna weights to maximize reception from Station C while still tuning out the primary stations. Station D will subsequently respond with a CTS packet containing its antenna weights. This transmission is now active and referred to as the secondary transmission. At this time, all other stations in the network update and store the information (such as antenna weights and transmission duration). Since it is not possible to accommodate more than two simultaneous transmissions, the other stations set their network allocation vector (NAV) to the expiration of the earliest transmission.

3.2.3.2 Scenario 2

Alternatively, if the secondary station determines the primary transmission completes during its ACK transmission, then that station proceeds with this transmission ac-

cordingly. This is when

$$\begin{array}{ccc} \text{RTS+SIFS}+\delta+\text{CTS} & & \text{RTS+SIFS}+\delta+\text{CTS} \\ +\text{SIFS}+\delta+\text{DATA} & < \Omega < & +\text{SIFS}+\delta+\text{DATA} \\ +\text{SIFS}+\delta & & +\text{SIFS}+\delta+\text{ACK}+\delta \end{array} \quad (3.11)$$

Since the duration of ACK is small compared to the transmission duration of the entire DATA packet exchange sequence, it is efficient to start the secondary transmission. In this case the responsibility is given to primary stations to perform collision avoidance. Since the primary stations are to observe the channel with a new weight vector for time equal to $\text{WSP}_{\text{partial}}$ following their transmission, they will observe a busy channel. As such they will defer for

$$\text{ACK} - \text{WSP}_{\text{partial}} \quad (3.12)$$

This guarantees completion of the secondary transmission. For fairness, all other observing stations set their network allocation vectors (NAVs) to the duration of the primary transmission plus the duration of an ACK. The timing diagram for this is shown in Figure 3.5(b).

3.2.3.3 Scenario 3

An inherent feature of MA-MAC is that when a primary transmission finishes, these stations are unaware of the details of any other ongoing transmission. To overcome this, secondary stations which are currently in the DATA packet transmission phase are required to relay information regarding their current transmission (including duration and antenna weights) with proper use of the weight sensing period (WSP). The secondary stations (i.e., Station C, Station D) convey the information regarding secondary transmission to the primary stations (i.e., Station A, Station B) using coordinated intelligent packet splitting. The decision bounds for this scenario are

$$\begin{array}{ccc} \text{RTS+SIFS}+\delta+\text{CTS} & & \text{RTS+SIFS}+\delta+\text{CTS} \\ +\text{SIFS}+\delta & < \Omega < & +\text{SIFS}+\delta+\text{DATA} \\ & & +\text{SIFS}+\delta \end{array} \quad (3.13)$$

In this case, the secondary stations (i.e., Station C, Station D) perform the weight sensing procedure as follows:

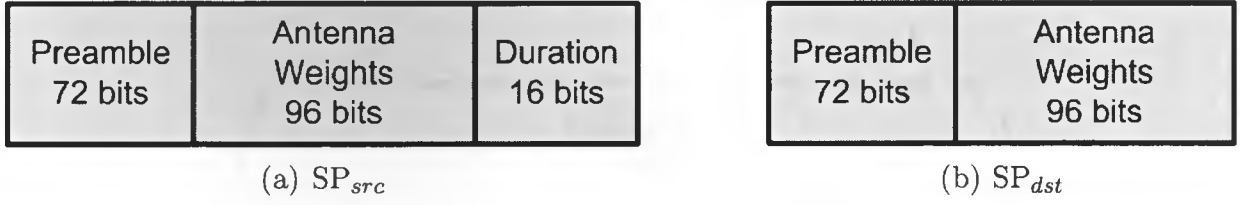

Figure 3.6: Weight Sensing Period Packet Formats

- At the instant the primary transmission completes, the secondary station transmitter (Station C) halts transmission of the DATA packet.
- After SIFS time, this station sends a SP_{src} packet containing antenna weights, transmission duration and pilot symbols for channel estimation.
- Following SP_{src} and a small time to account for propagation delay, the secondary receiving station (Station D) sends a SP_{dst} packet containing antenna weights and pilot symbols for channel estimation.
- Again after SIFS time, the secondary transmitter attaches a short PHY header to the remaining portion of the DATA packet (now referred to as $DATA_{frag,2}$).
- At this time, the secondary stations are now referred to as primary stations and are governed by MAC operation for primary stations.

The timing diagram for WSP is shown in Figure 3.5(c). The packet formats for both SP_{src} and SP_{dst} are shown in Figures 3.6(a) and 3.6(b) respectively. Both packets contain the weights currently used by the secondary stations as well as pilot symbols embedded in the PHY preamble for channel estimation. Furthermore, SP_{src} contains the duration of the remaining portion of transmission.

3.2.3.4 Scenario 4

Occasionally the residual time Ω is insufficient to complete a successful RTS/CTS exchange, meaning:

$$\Omega < \text{RTS} + \text{SIFS} + \delta + \text{CTS} + \text{SIFS} + \delta \quad (3.14)$$

In this case the station does not send an RTS packet and alternatively defers to the end of the primary transmission as well as increment its backoff counter. This action

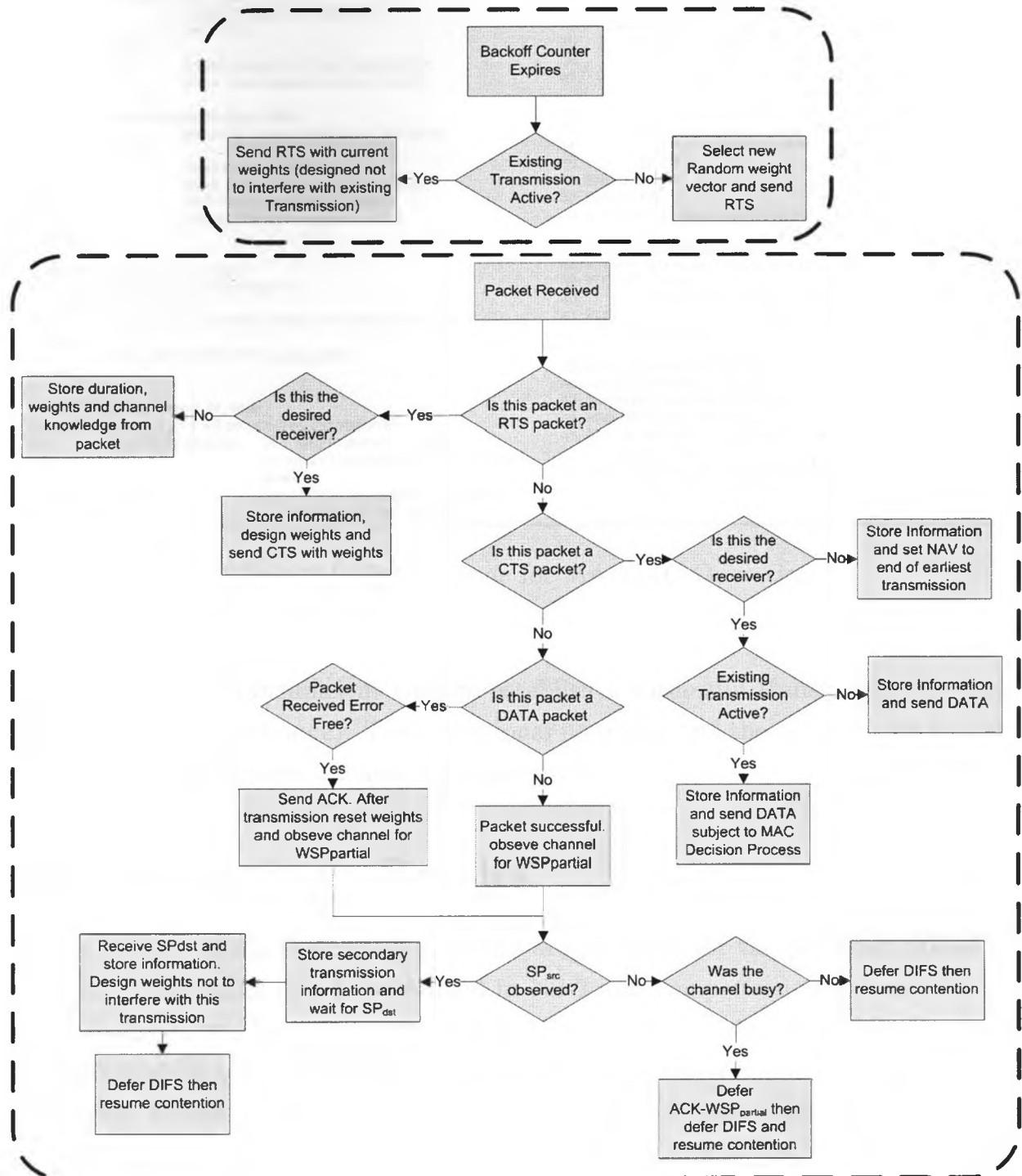

Figure 3.7: Flowchart of MA-MAC Operation

```

RECEIVE_RTS(channel)
//When any station receives RTS packet
1. IF channel is idle THEN
2.     IF station is destination THEN
3.         Design Weights for best SNR;
4.         Send CTS;
5.     ELSE
6.         Design Weights to NULL transmission;
7.         Store Transmission Duration in NAV1;
8. ELSE
9.     IF station is destination THEN
10.        Send CTS using weights to not interfere;
11.    ELSE
12.        Store Antenna Weights;
13.        Store Transmission Duration in NAV2;
14.        SET NAV to min(NAV1,NAV2);
15.        FREEZE backoff counter;
16. END if

CHANNEL_CONTENT(channel)
//When a stations backoff counter reaches zero
17. IF channel is idle THEN
18.     Send RTS (compete for access) with Random Weights;
19. ELSE
20.     MAC_DECISION(NAV1_expire_time);
21. END if

MAC_DECISION(primary_tx_end)
22. CASE primary_tx_end will occur during this station's:
23.     RTS/CTS exchange: SET NAV to primary_tx_end;
24.                     Increment Contention Window; //Case 4
25.                     break;
26.     ELSE:             Send RTS with weights to not interfere
                        with primary transmission;

FINISH_TRANSMISSION_1()
//When station finishes transmission as primary
27. Listen to channel for WSPpartial time;
28. IF channel is NOT idle THEN
29.     IF SPsrc received THEN
30.         Listen for and receive SPdst;
31.         Store antenna antenna weights and channel
            information;
32.         Store Transmission Duration in NAV1
33.     ELSE
34.         Defer ACK-WSPpartial;
35.     END if
36. END if
37. Defer DIFS;
38. Start decrementing backoff counter;

FINSH_TRANSMISSION_2()
//When station finishes transmission as secondary
39. IF Case 2 THEN
40.     Defer primary_tx_end + ACK + DIFS;
41. ELSE //Case 1
42.     Defer DIFS;

WEIGHT_SENSING_PERIOD()
//Secondary station action at primary_tx_end if Case 3
43. Secondary transmitter halts DATA2 transmission;
44. After SIFS time, send SPsrc;
45. After an allotment for propogation delay, secondary receiver
    sends SPdst;
46. After SIFS time, secondary transmitter sends
    DATAfrag,2 with additional PHY header;

```

Figure 3.8: Pseudo-code for MA-MAC Operation

is taken as there is insufficient time to establish a successful transmission (perform RTS/CTS packet exchange). The operational flowchart and the pseudo-code for MA-MAC is given in Figures 3.7 and 3.8 respectively.

3.3 Performance Results

In this section, detailed simulation results are provided for the proposed MA-MAC protocol. This evaluation is performed in NS-2 and comparisons are done with respect to the previously proposed SPACE-MAC protocol. As previously discussed, the performance of SPACE-MAC relies heavily on the selection of its silence period parameter, therefore comparisons are drawn for each network configuration with an optimized value of this silence period. The standard parameters used are shown in Table 3.1, other parameters are as specified.

As the goal of utilizing MA-MAC is to increase the overall MAC layer datarate, firstly results are presented for a saturated network. This is a network in which at all times, all stations have remaining packets in their buffer to be transmitted

Table 3.1: MA-MAC Simulation parameters

Parameter	Value	Parameter	Value
SIFS	10 μ s	DIFS	50 μ s
Slot Time	20 μ s	SP _{src}	184 bits
SP _{dst}	168 bits	DATA _{frag2} PHY header	72 bits
WSP _{partial}	194 μ s	WSP	450 μ s
Propagation delay (δ)	6 μ s	PHY Data Rate	1Mbps
CW _{min}	32	CW _{max}	1024
RTS (MA-MAC)	56 bytes	CTS (MA-MAC)	50 bytes
RTS (SPACE-MAC)	58 bytes	CTS (SPACE-MAC)	52 bytes

on the channel. These results will demonstrate the maximum datarate which can be utilized by the MAC layer for data transmission. Secondly, an unsaturated network is examined. Unlike the saturated case, this network incurs idle periods where stations have empty buffers. In such a scenario, the throughput for both protocols is the same and the packet delay is the metric of interest.

3.3.1 Saturated Performance

3.3.1.1 Overall Improvements

In order to evaluate the performance of MA-MAC and SPACE-MAC schemes under saturated conditions, a network scenario is created with stations that send fixed size packets at a constant bit rate equal to the maximum data rate offered by the MIMO physical (PHY) layer (i.e., 1 Mbps from Table 3.1). This forces all stations to always be in saturated condition as they always have packets to send in their buffer. In these simulations, all the stations are located within the transmission range of each other and therefore exist in a single collision domain. The performance of both MA-MAC and SPACE-MAC is shown for varying number of stations in order to provide an overall comparison of saturated throughput for these protocols. Throughput in this work is defined as the ratio of the MAC layer throughput with respect to the offered PHY layer datarate.

Figure 3.9 shows the performance under saturated conditions for a varying number of stations. It can be seen that MA-MAC performs better than the best performance achievable with SPACE-MAC. The throughput for both protocols is shown

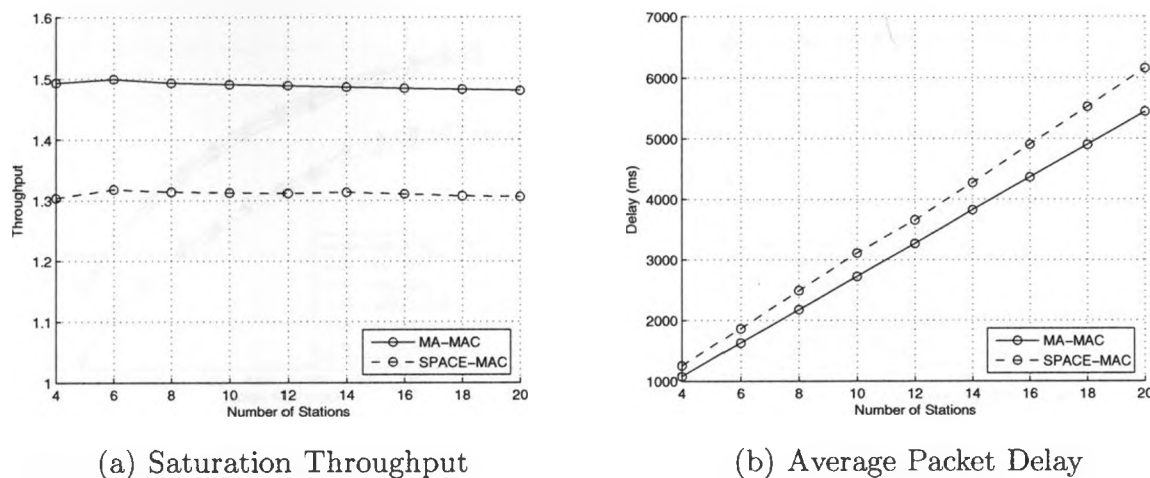

Figure 3.9: Performance vs Network Size under Saturated Conditions

in Figure 3.9(a). The achievable overall throughput using SPACE-MAC is approximately 1.3, whereas MA-MAC achieves more than 1.5 in overall throughput. Though delay values under saturated conditions have little significance, the average delay experienced by the transmitted data packets in MA-MAC is smaller when compared to SPACE-MAC for all network sizes (see Figure 3.9(b)).

3.3.1.2 Effect on Network Parameters

The same saturated network scenario is utilized to examine the effects of various network parameters on the performance of MA-MAC. In this case individual parameters are varied independently to study their effect on the overall network throughput.

Figure 3.10 shows the performance of both schemes for varying packet and network sizes. The throughput of both protocols increases with respect to packet size. As shown, as the network size increases, the throughput is reduced for both protocols. This is a result of the greater number of collisions experienced in the dense network. Both protocols experience this similar trend, however the overall throughput for MA-MAC is significantly larger than that of SPACE-MAC. This is due to the inefficiency present in the need for large silence periods in SPACE-MAC.

In Figure 3.11 the packet size is fixed to 1024 bytes, and the size of the minimum contention window is varied for both protocols. The maximum number of backoff stages is also set to 6. It is observed that the contention window size that offers

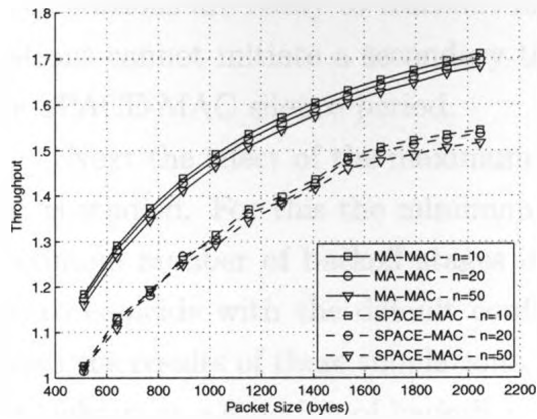

Figure 3.10: Throughput vs Packet Size

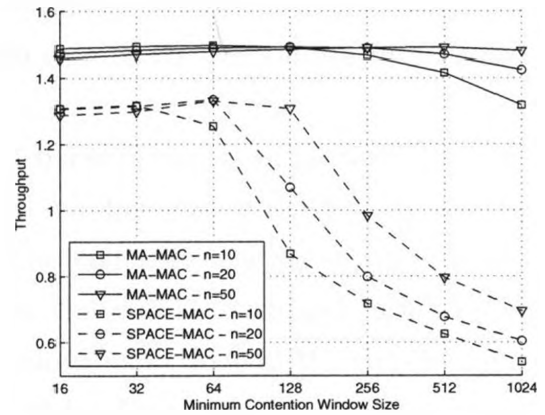

Figure 3.11: Throughput vs Window Size

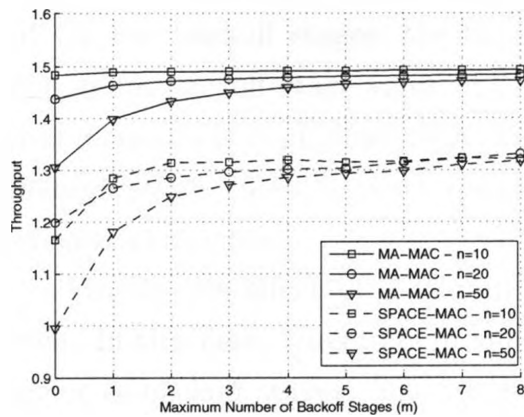

Figure 3.12: Throughput vs Backoff Stages

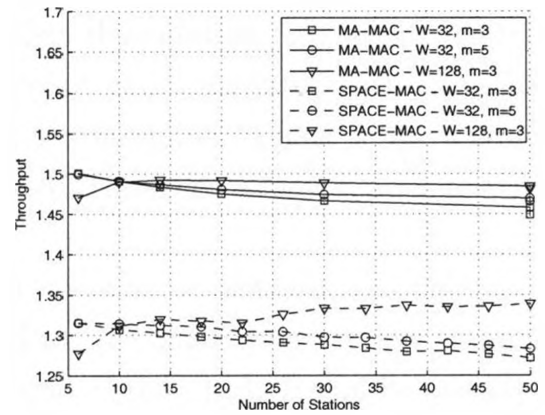

Figure 3.13: Throughput vs Stations

the maximum throughput depends largely on the number of stations in the network. For MA-MAC, the maximum throughput is achieved when the minimum contention window is set to 64 with a network size of 10 stations, however for a 50 station network, the window size must be 512 to achieve the best performance. Furthermore, increasing the window further beyond the maximum point results in large degradations in the throughput. By varying the window size for SPACE-MAC, a major limitation is revealed in the protocol operation. Examining once again Figure 3.11, there is a rapid reduction in throughput for SPACE-MAC once a threshold window size is reached based on the number of stations in the network. This occurs as the residual time in SPACE-MAC (the time threshold for which a station decides to transmit) is small

when stations are ready to transmit following such large backoffs, as such, frequently stations cannot initiate a secondary transmission due to the restriction imposed via the SPACE-MAC silence period.

Next the effect of the maximum number of backoff stages on network throughput is studied. For this the minimum contention window size is fixed to 32 and the maximum number of backoff stages is varied. The contention window value is chosen to coincide with the default configuration in the 802.11 standard. Figure 3.12 shows the results of these simulations. For 10 stations using MA-MAC, the change in throughput as a function of backoff stage is negligible. This is due to the low number of stations involved in collision since a station which successfully sends a packet will not enter an additional backoff stage. For 20 and 50 station scenarios, it is observed that for low backoff stages, the throughput suffers degradation. At approximately a maximum backoff stage value of 6, the throughput gain associated with any additional increases is negligible. SPACE-MAC experiences similar trends as the number of backoff stages increases with respect to MA-MAC, however achieves lower relative aggregate throughput.

Finally the effect of a varying number of stations on network throughput is shown. In this case, three sets of values are used for the contention window size and number of backoff stages. The results are shown in Figure 3.13. It can be observed that the throughput of both protocols reduces for an increasing number of stations. The window size of 128 offers the highest throughput for a large number of stations. It can be observed that when there are a small number of stations, there are many wasted idle slots causing a reduction in throughput. For a window size of 128 and a maximum backoff stage of 3, SPACE-MAC however experiences a slight gain in throughput unlike MA-MAC. This is due to the modification of the silence period parameter in SPACE-MAC to allow it to achieve maximum throughput for each set of parameters.

3.3.1.3 Fairness

The fairness of the MA-MAC protocol is also studied thoroughly for numerous network sizes and under different scenarios. For clarity the results are presented for only 6 and 12 stations scenarios. The throughput and delay observed for each station in these scenarios are tabulated to compare fairness. All the stations are under saturated conditions and send 1024 bytes packets at a constant bitrate. All other parameters

Table 3.2: MA-MAC Fairness Comparison for 6 and 12 Station Networks

Station ID	Throughput (kbps)	Delay (ms)	Throughput (kbps)	Delay (ms)
1	259.41	1571	128.12	3182
2	256.39	1589	128.75	3162
3	254.22	1603	123.04	3312
4	259.29	1571	122.49	3325
5	246.83	1651	131.79	3093
6	249.10	1635	128.45	3170
7	—	—	125.06	3261
8	—	—	127.65	3194
9	—	—	119.44	3413
10	—	—	129.16	3146
11	—	—	121.90	3342
12	—	—	126.22	3225
Std. Deviation	8.05	33.38	3.65	95.38

are found in Table 3.1. These results are presented in Table 3.2. From the Table, it can be observed that the proposed MA-MAC scheme provides a reasonable degree of fairness to all the wireless stations on the channel which is clear by the low standard deviation of both throughput and delay.

3.3.2 Unsaturated Performance

In addition to the maximum MAC layer data rate of MA-MAC, the delay performance is also of interest under unsaturated conditions. For this study, the networking scenario shown in Figure 3.14 is created. All these stations are located in a single collision domain and have a queue length of 50 packets. Bi-directional transmission is enabled between the wireless stations as shown in the diagram. The transmissions are denoted as uplinks and downlinks for identifying the direction of data transmission between stations. For example, Station A uses downlink to transmit to Station B while Station B uses uplink to transmit to Station A. All wireless stations are transmitting at 64 kbps for both types of links.

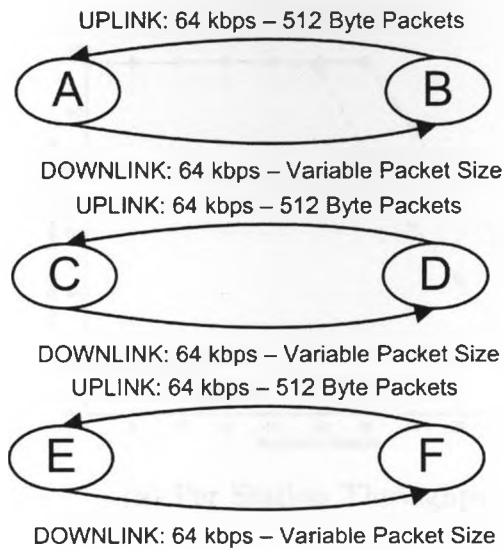

Figure 3.14: Unsaturated Network Scenario

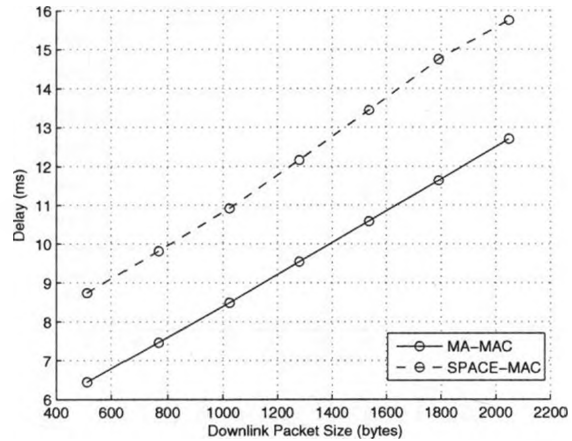

Figure 3.15: Delay vs Downlink Packet Size under Unsaturated Conditions

3.3.2.1 Effect of Link Packet Size

By varying the data packet size of the downlink, observations can be made on the overall packet delay. For this, stations transmit at a constant bit rate with uplinks transmitting 512 byte packets while varying the size of downlink packets to study the effect on packet delay. The average delay per station for both MA-MAC and SPACE-MAC is shown in Figure 3.15. From this, it is observed that the overall average packet delay experienced in the network increases linearly as the data packet length of the downlink is varied. More importantly, the average delay experienced per packet for MA-MAC is approximately 20 – 25% less than that achievable with SPACE-MAC.

3.3.2.2 Effect of Increasing Number of Stations

It is also important to determine the maximum number of users that can transmit without overloading the network. For this, the unsaturated scenario is again used, however the number of links is steadily increased while measuring the throughput and delay of each station (i.e., instead of having 6 stations form three pairs of links, x stations will form $\frac{x}{2}$ links). Both uplinks and downlinks have fixed packet sizes of 512 bytes. The results are shown in Figure 3.16. MA-MAC performs better than SPACE-MAC as the network size increases. Infact, MA-MAC is able to allow 2 more

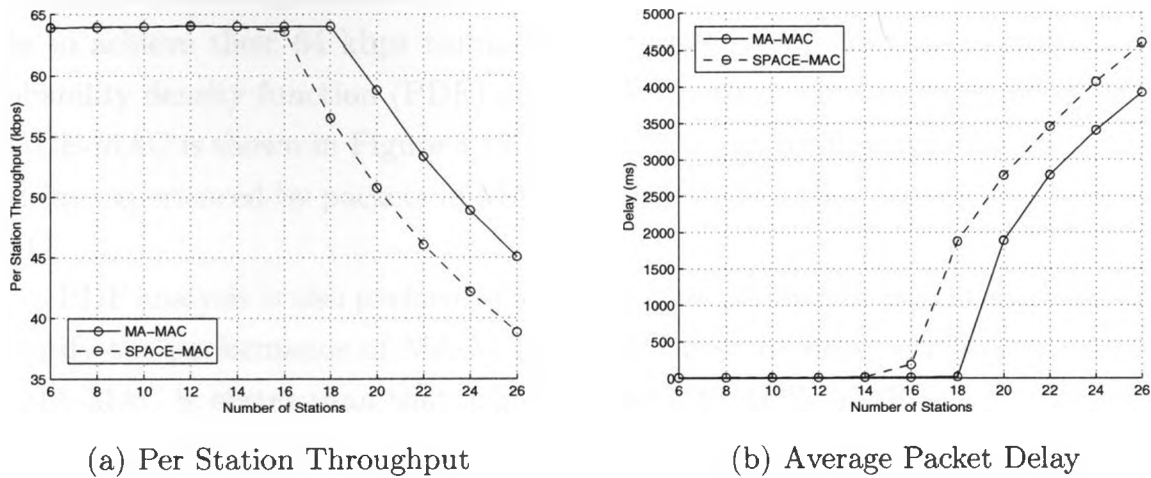

Figure 3.16: Unsaturated Performance versus Network Size

links than SPACE-MAC without sacrificing per station throughput and entering into saturation.

3.3.2.3 Packet Delay Distribution

It has been shown that the per packet delay for MA-MAC is less than that of SPACE-MAC. This can further be revealed by analyzing the distribution of packet delay for the unsaturated network scenario. The previously used unsaturated network scenario is employed with 10 stations. The number of stations for this scenario is chosen after

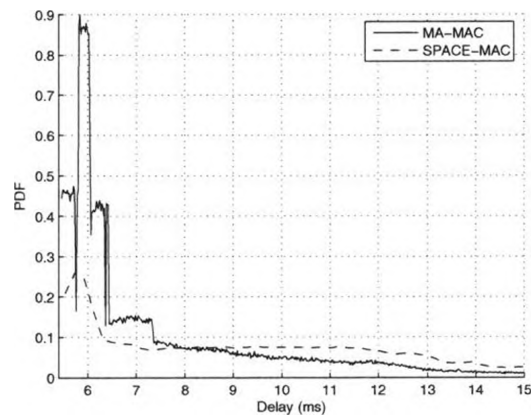

Figure 3.17: PDF of Packet Delay. 10 Station Network stations.

studying the results presented in Figure 3.16 as at this network size all stations are able to achieve their 64 kbps throughput irrespective of the chosen protocol. The probability density function (PDF) of the delay performance for both MA-MAC and SPACE-MAC is shown in Figure 3.17. From this it can be observed that the variation in delay experienced by packets in MA-MAC is less than that experienced in SPACE-MAC.

PDF analysis is also performed for other network sizes in unsaturated conditions to verify the performance of MA-MAC. In all cases the delay performance achieved by MA-MAC is better than that achievable with SPACE-MAC.

3.4 Protocol Remarks

The work in this Chapter has demonstrated the ability of the proposed MA-MAC scheme of offering improved performance for MIMO systems. The protocol was thoroughly evaluated and shown that by making proper scheduling decisions, can offer improvements upwards of 25% in terms of throughput and delay versus recently proposed MIMO MAC protocols.

These improvements were confirmed for networks under both saturated and unsaturated conditions. Furthermore, the proposed scheme is robust to varying network conditions and is not dependant on empirically designed parameters.

In the next Chapter, the role of MAC protocols in service differentiation is addressed. In this work, a new point-to-multipoint protocol is introduced to handle service differentiation of voice, video and best-effort data traffic.

Chapter 4

Television Time-Division Multiple Access

Another role of the media access control layer is to provide service differentiation to packet data. This service differentiation is in the form of providing Quality of Service (QoS) to various types of network traffic.

In this chapter, Television Time-Division Multiple-Access (TV-TDMA) is discussed. This protocol is an application-based point-to-multipoint MAC protocol designed to provide triple-play services (video, voice and data) delivery to four subscriber stations over existing physical layer technologies.

4.1 Motivation

Currently, data networks are being used to carry a number of services. Every component of the network must be able to handle the requirements of these individual services. The local area network is the final segment of the delivery path for this data. This is frequently referred to as the “last-mile”. As stated, in this work, triple-play services are to be delivered to end-users from a central hub. To identify the needs of a new MAC design in order to achieve these system requirements, an evaluation of existing WLAN protocols is performed to identify the limitations of these protocols in meeting these demands.

4.1.1 System Requirements

The goal of the target system is to provide triple-play services to four subscribing stations while maintaining Quality of Service to each station. The specific requirements outlined for each traffic class is listed below.

- Video (downlink only):
 - Format - MPEG-2 (Variable Bitrate)

- Target bitrate - 4Mbps
- Resolution - 720x480 pixels
- Frame Rate - 30Hz
- Audio Rate - 128kbps (Stereo)
- Voice (duplex):
 - Format - G.711
 - Bitrate - 64kbps
 - Packet Rate - 50 packets per second
- Data (duplex):
 - Best-effort support for both downlink and uplink data

As previously stated, the application requires delivery of services over existing physical layer technologies. The advantage of the proposed reasoning is two-fold. Firstly, as existing technologies such as 802.11a/b/g utilize the unlicensed spectrum, there is no cost incurred as no licensing of additional spectrum is required. Furthermore, the wide-availability and low-cost of consumer 802.11x equipment eliminates the requirement of custom hardware design. For this reason, a number of researchers have recently used 802.11x based hardware for implementation of custom MAC schemes [29, 30, 31].

In this work, the 802.11a physical layer is focused on as the number of devices operating in the 5GHz band is low thereby reducing the amount of co-channel interference in the system.

4.1.2 Existing Designs

In order to assess the need for design of a application-based MAC scheme, the performance of existing MAC protocols must first be examined. The specifics of the protocols examined are described below.

4.1.2.1 Distributed Coordination Function

The 802.11 distributed coordination function (DCF) is an access mechanism utilized in the 802.11a/b/g series of technologies. This mechanism is mandatory in any hardware that is compatible to the standard. It allows for distributively controlled access to the wireless channel, with no differentiation between traffic categories.

4.1.2.2 Point Coordination Function

The 802.11 point coordination function (PCF) is an optional access mechanism for centralized control with an access point. PCF utilizes two periods: a contention-free period (CFP) and a contention-period (CP). During the CFP, the access point polls stations on its polling list. During this poll, both the access point can send data in the downlink and stations can send data in the uplink. The remaining portion (un-pollled) portion of the PCF Frame is the CP. The CP utilizes the mandatory DCF access mechanism described above.

4.1.2.3 Enhanced DCF

The 802.11e Enhanced DCF (EDCF) is a distributed QoS capable MAC. This protocol is again mandatory for devices conforming to the 802.11e standard. Traffic differentiation is employed by defining eight priority categories that are mapped to four access categories of traffic. Each of these access categories maintains a set of access parameters to control individual access to the channel. The design of the access parameters favour higher priority traffic. In addition, EDCF also contains several other QoS enhancements such as contention free bursting (CFB) which allows a station to send several packets without contending again for the channel. There is also an optional block acknowledgment mechanism to reduce the number of acknowledgement packets transmitted.

4.1.2.4 Hybrid Coordination Function Controlled Channel Access

In addition to EDCF, the 802.11e standard defines HCCA, a centralized access mechanism. HCCA also provides Quality of Service standards to different traffic classes. In this scheme, an access point allows or disallows requests for traffic streams (TSs). A TS request is initiated by a station wishing to transfer Quality of Service enabled

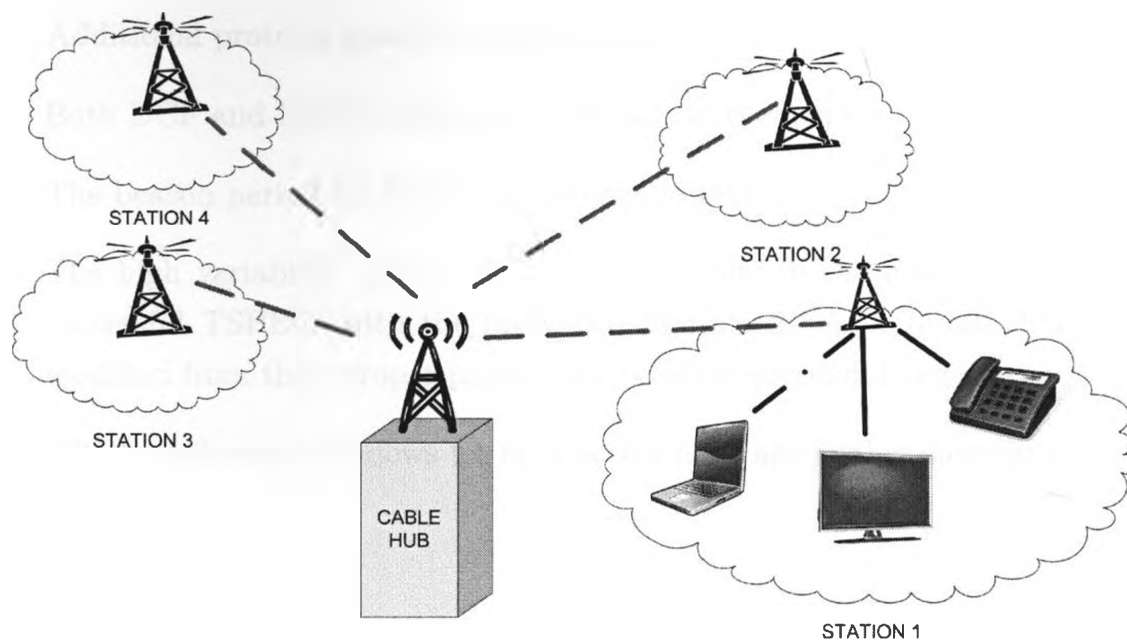

Figure 4.1: Point-To-Multipoint Wireless Network Scenario

traffic. Each TS request contains a set of specifications (TSPECs) with specific information on the QoS requirements. With this knowledge, the access point schedules various controlled access periods (CAPs) in which the access point controls traffic. The design of the scheduler is not defined in the standard, however a reference scheduler design is provided. During the remainder of the frame, stations may also access the medium using EDCF.

4.1.3 Performance of Existing Protocols

4.1.3.1 Evaluation System

The above protocols were implemented in the ns-2 environment to validate their performance for the application. The EDCF model from [24] is used, while the HCCA model from [25] is used. The point-to-multipoint scenario in Figure 4.1 is used where a cable hub delivers services to the four stations. Firstly, only downlink video and bidirectional G.711 voice is employed with parameters configured as laid out in the system requirements.

The video stream statistics are shown in Table 4.1. The performance is measured over an 802.11a physical layer where the configured physical parameters are shown in Table 4.2. All stations are also located within the same collision domain.

Additional protocol specific configuration includes:

- Both DCF and EDCF utilize the basic access mechanism.
- The beacon period for PCF is configured to 20ms.
- The high variability of the video bitrate results in the inability to negotiate successful TSPECs with the proper configuration. As a result, TSPECs are modified from their proper parameters to allow successful negotiation¹.
- EDCF contention windows for each access class are further summarized in Table 4.3.

Table 4.1: Encoded Video Statistics

Video Number:	1	2	3	4
Average Bitrate:	4.13Mbps	3.81Mbps	3.64Mbps	3.36Mbps
Minimum Frame Size:	829B	821B	821B	821B
Mean Frame Size:	17.2×10^3 B	15.9×10^3 B	15.2×10^3 B	14.0×10^3 B
Maximum Frame Size:	83.9×10^3 B	105.3×10^3 B	103.2×10^3 B	93.4×10^3 B

Table 4.2: 802.11a Physical Layer and Universal Parameters for ns-2

Parameter	Value	Parameter	Value
CW_{min}	15	CW_{max}	1023
Slot Time	$9\mu s$	SIFS Time	$16\mu s$
PIFS Time	$25\mu s$	DIFS Time	$34\mu s$
PLCP and Basic Datarate	6Mbps	PLCP Header Size	40 bytes
Preamble Size	96 bytes	Data Rate	54Mbps
Packet Error Rate	1%	Short Retry Limit	4
Long Retry Limit	7	TX Buffer Size	200 Packets

¹Modifying TSPECs has a negative effect on performance of the reference scheduler. This results in low performance of HCCA for the variable bitrate traffic as shown in the results.

Table 4.3: EDCF Priority Queue Parameters

Traffic Category:	Voice	Video	Best-Effort	Background
CW_{min} :	3	7	15	15
CW_{max} :	7	15	1023	1023
AIFS ² :	2	2	3	7
TXOP:	1504 μ s	3008 μ s	—	—

4.1.3.2 Video and Voice Results

In Table 4.4, the results for the video and voice streams are presented for all four existing protocols. The results show that EDCF offers the best performance for the variable bitrate video with regards to the number of dropped frames and average frame delay. HCCA offers the worst performance for this video traffic. This is due to the design of the scheduler and the improper negotiation of TSPECs. Additionally, the high frame loss associated with HCCA is because with HCCA, a packet that is not serviced before its specified delay tolerance will not be serviced at all.

For voice traffic, EDCF also offers the best performance for the uplink voice, however HCCA performs best for the downlink (which can be seen by the negligible delay standard deviation). This is because the HCCA reference scheduler performs well for constant bitrate scheduling.

Overall, EDCF offers the best performance in terms of handling both variable bitrate video and bidirectional voice. Next, the evaluation system in Figure 4.1 again used, with the addition of best-effort data traffic and evaluated using EDCF (as it offers the best performance of all schemes). This is used to measure the ability of delivering best-effort services along with video and voice traffic. For best-effort traffic, a downlink and uplink to each station is setup with constant bitrate traffic. Packet sizes are fixed to 1024 bytes with the downlink and uplink datarates configured to 3Mbps and 1Mbps respectively. These datarates are comparable to moderate level service rates offered by major internet service providers [32, 33].

The overall best-effort throughput on the downlink was 1.43Mbps on average per station, while the average uplink achieved 1Mbps (as configured). At these datarates,

²When AIFS is represented by a number n , the value of $AIFS(n) = SIFS + nSlot_Time$.

Table 4.4: Existing Protocols Performance Results for Video and Voice Traffic

Station Number:	1	2	3	4
Number of Sent Frames:	15000	15000	14994	14999
Video Bitrate:	4.13Mbps	3.81Mbps	3.64Mbps	3.36Mbps
<u>DCF</u>				
Received Frames:	14734	14758	14744	14746
Dropped Frames:	266	242	250	253
Avg. Frame Delay:	8.16ms	8.29ms	8.26ms	8.23ms
Voice Packets (Up/Down):	100/99.63%	100/99.48%	100/99.49%	100/99.40%
Avg. Delay (Up/Down):	0.60/8.83ms	0.63/8.88ms	0.61/9.04ms	0.60/9.07ms
Delay Std. Dev. (Up/Down):	0.48/20.13	0.47/19.91	0.45/19.96	0.44/19.86
<u>PCF</u>				
Received Frames:	14936	14942	14938	14939
Dropped Frames:	64	58	56	60
Avg. Frame Delay:	3.22ms	3.24ms	3.27ms	3.21ms
Voice Packets (Up/Down):	100/99.39%	100/99.26%	100/99.31%	100/99.39%
Avg. Delay (Up/Down):	0.61/3.18ms	0.66/3.34ms	0.64/3.41ms	0.63/3.46ms
Delay Std. Dev. (Up/Down):	0.33/9.10	0.40/9.23	0.58/9.12	0.67/9.09
<u>EDCF</u>				
Received Frames:	14996	14995	14991	14993
Dropped Frames:	4	5	3	6
Avg. Frame Delay:	0.90ms	0.91ms	0.93ms	0.89ms
Voice Packets (Up/Down):	100/100%	100/100%	100/100%	100/100%
Avg. Delay (Up/Down):	0.33/0.25ms	0.46/0.27ms	0.35/0.40ms	0.32/0.28ms
Delay Std. Dev. (Up/Down):	0.33/0.18	0.40/0.19	0.30/0.26	0.29/0.21
<u>HCCA</u>				
Received Frames:	11029	10249	10379	10355
Dropped Frames:	3971	4751	4615	4644
Avg. Frame Delay:	22.8ms	36.9ms	29.8ms	38.3ms
Voice Packets (Up/Down):	100/97.89%	100/98.06%	100/97.98%	100/98.02%
Avg. Delay (Up/Down):	4.17/19.2ms	4.17/19.4ms	4.17/19.5ms	4.19/19.7ms
Delay Std. Dev. (Up/Down):	2.64/0.0	2.61/0.0	2.63/0.0	2.64/0.0

Note: Received and dropped frames as well as the average frame delay consists of both I and P-Frames. Voice packets represents the successful reception rate for the uplink and downlink voice packets. These results are in the presence of voice and video traffic only.

the network has reached saturation and cannot accommodate any additional traffic. The total network throughput in this scenario is approximately 25Mbps (by combining the rates achieved by each traffic flow). This is less than half of the physical data rate (54Mbps). The reason for such low MAC layer throughput is due to a number of factors including:

- Packet errors due to channel (retransmissions).
- Packet errors due to collision (retransmissions).
- Contention mechanism (idle slot times)
- Physical layer overhead (preamble and PLCP header)
- MAC layer overhead (802.11 headers)

The physical layer overhead is a function of the physical layer employed. For a fixed physical layer, this is little that can be done for improvement.

MAC layer overhead may be reduced by employing reduced size MAC headers as the 802.11e MAC headers are 32 bytes in length. In addition, use of the Stop and Wait ARQ mechanism means that acknowledgements must be received for each individual packet resulting in this additional MAC overhead.

Collision and excess idle times can be eliminated by use of a TDMA-based access scheme. The need is clear when examining the above scenario. The total time wasted in collisions and idle slots is approximately 16%³ of the total channel time which is a large percentage of wasted time.

Finally, packet errors due to the channel is a function of the propagation environment, however error control coding or rate adaptation can be used to reduce its effects. In addition, retransmissions of time-sensitive traffic may be reduced or eliminated.

4.2 Protocol Operation

In order to meet the demands required, this section introduces the design of TV-TDMA, an application-based TDMA MAC scheme. This MAC scheme is designed to

³Measured from the simulation of EDCA with video, voice and best-effort traffic.

provide QoS to four subscribing stations in a point-to-multipoint network. TV-TDMA addresses the limitations of existing schemes (such as DCF and EDCF) by providing a centralized scheduling mechanism to reduce overhead by eliminating collisions, idle times and per packet acknowledgement. TV-TDMA also provides a dynamic packet allocation scheme to meet QoS requirements.

4.2.1 TV-TDMA Frame

TV-TDMA operates frame-by-frame. Each TV-TDMA frame is divided into two sub-frames: downlink and uplink. This is similar to the 802.16 (WiMAX) scheme [34]. The downlink frame is used to transmit packets from the access point to the subscriber stations, while the uplink subframe is used to transmit packets from the individual subscriber stations to the access point. Guard intervals are instituted to eliminate collisions of downlink and uplink packets. The TV-TDMA frame is shown in Figure 4.2.

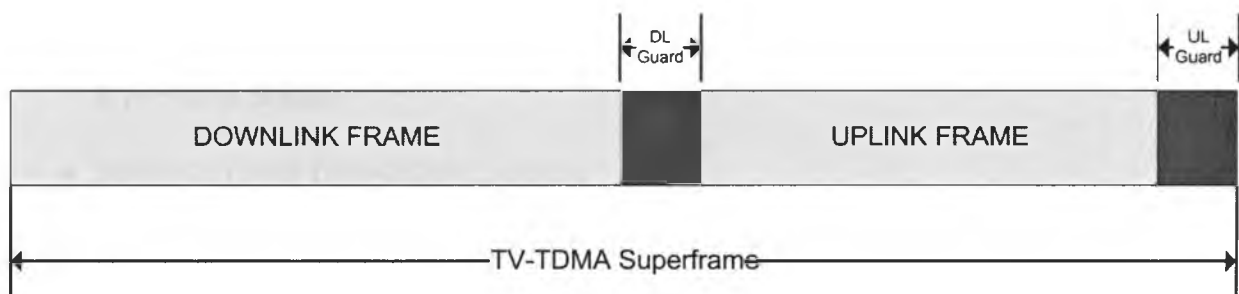

Figure 4.2: TV-TDMA Superframe

4.2.1.1 Downlink Frame

The design of the downlink frame is shown in Figure 4.3. The downlink first begins with a beacon packet. This packet contains information required to schedule all stations within this frame. Following this, the access point will send one voice packet if available to each station in sequence. The duration of these packets (and as such their location within the frame) is fixed to reduce jitter. The remainder of the frame is divided into four variable length downlink slots. Each slot transmits data to a given subscribing station. During this slot, the AP transmits in the following order:

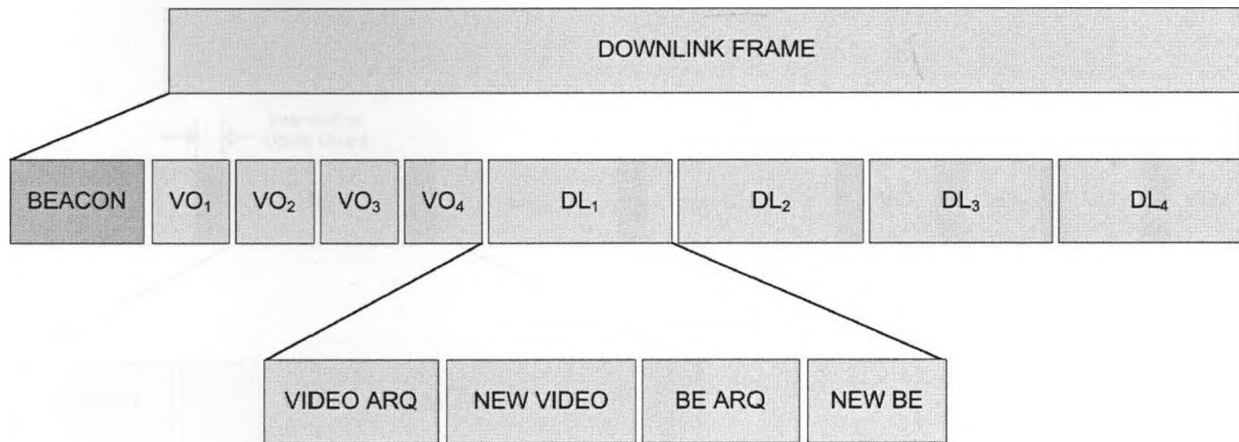

Figure 4.3: TV-TDMA Downlink Frame

- Video ARQ Queue (packets which are being retransmitted from a previous frame)
- Video Queue (newly arrived video packets)
- Best-Effort ARQ Queue (best-effort packets which are being retransmitted from a previous frame)
- Newly arrived Best-Effort packets

The number of packets of each type transmitted during each downlink slot is controlled by the allocation algorithm and is discussed in detail in Section 4.2.4.

4.2.1.2 Uplink Frame

The design of the uplink frame is shown in Figure 4.4. This frame is again divided into eight slots. The first four variable length slots are for best-effort packets (one slot for each station), while the latter four are for uplink voice packets (if available). The placement of the uplink voice packets is such that their location in each frame remains fixed to reduce jitter.

The size of each best-effort uplink slot is determined by the uplink map. This uplink map is contained in the beacon packet broadcast at the start of each frame. The AP assigns an uplink slot to each station based on the slot time requested. For this reason, all subscribing stations provide feedback of their current buffer sizes to the access point during each frame in the header of uplink voice packets. The AP utilizes this knowledge to schedule transmissions and allocate slots during the frame.

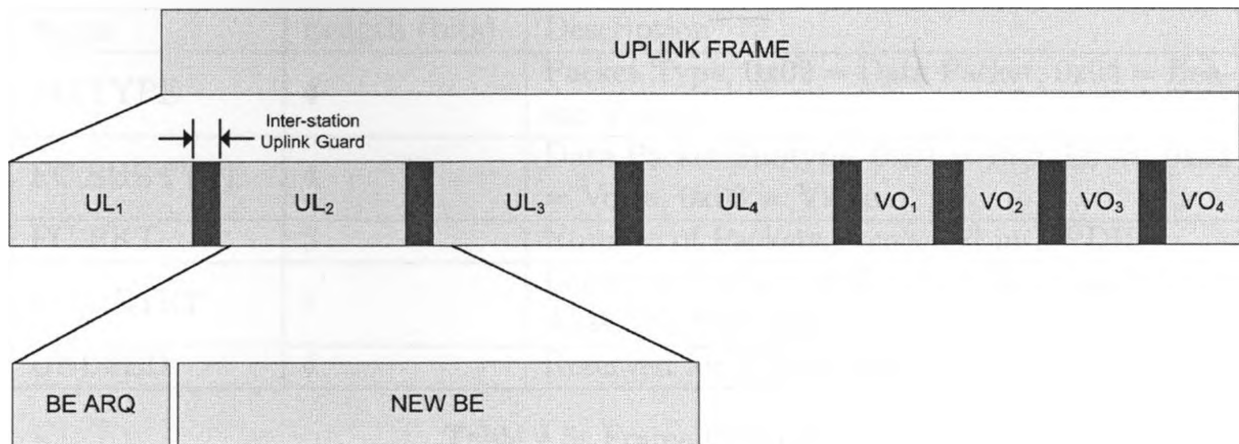

Figure 4.4: TV-TDMA Uplink Frame

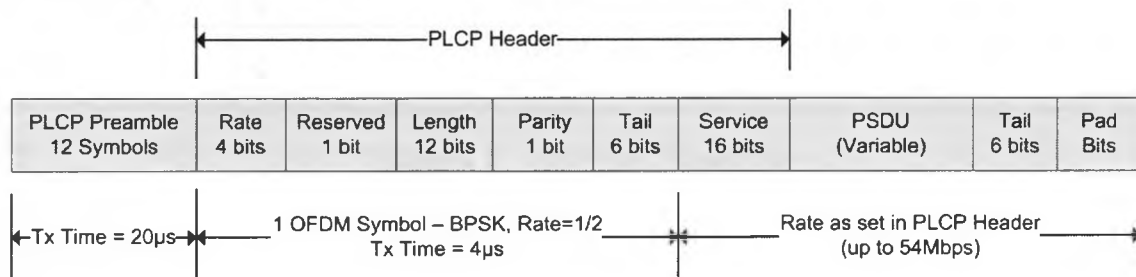

Figure 4.5: 802.11a Packet

4.2.2 Packet Formats

In this section, the packet formats are described. All packets contain the physical layer preamble as well as the PLCP header at the beginning of the frame. These are described in the 802.11a physical layer specifications [35]. This format is shown in Figure 4.5. The preamble is used to synchronize and prepare the receiver for packet reception while the PLCP header also contains the data rate at which the MAC payload will be transmitted. The PSDU shown in Figure 4.5 is the Physical layer Service Data Unit. This is the MAC payload data (including MAC headers). In all MAC payload headers, the first two bits are the Frame Control. The format of this entry is shown in Table 4.5. In addition, TV-TDMA utilizes a unique addressing scheme. An address entry is stored as 1 byte. Four bits are used to represent the network ID while the other four are used to denote the host ID. The network ID is shared among all subscriber stations while the host ID is unique. A host ID of 0x00 denotes the access point. Each bit in the host ID defines a particular station (i.e., bit 1 → Station 1, bit 2 → Station 2, etc.). With this method, a broadcast by the access point will involve setting all bits

Name	Length (bits)	Description
FC_TYPE	4	Packet Type, 0x02 = Data Packet, 0x04 = Beacon Packet
FC_SUBTYPE	4	Data Packet Subtype, 0x01 = Best-Effort, 0x02 = Voice, 0x03 = Video
FC_PKT	3	Number of Packets Contained in MPDU
FC_RETRY	1	Legacy Retry bit for Hardware Implementation, ALWAYS SET TO 1
UNUSED	4	Reserved for Future Use

Table 4.5: Frame Control

Name	Length (bits)	Description
NETWORK	4	Network ID Shared amongst stations in network
HOST	4	Station ID, 0x00 = Access Point, otherwise Station ⁴

Table 4.6: Address Structure

of the host id (or 0x0F). This addressing scheme is used to provide future support for multicast transmissions.

4.2.2.1 Beacon Packet

The beacon packet is responsible for disseminating frame information to all the subscriber stations. The structure of the beacon packet is shown in Figure 4.6. As shown the beacon packet contains the upload map (ULMAP). The ULMAP contains information regarding the upload slot location, duration and assigned station. Both the slot duration and the location of the slot is stored as a 16 bit integer representing the size in microseconds. This location is stored as an offset measurement. This offset measurement is referenced from the time of reception of the beacon packet. In total, there are 8 ULMAP entries: two allocated per station. The first slot is variable length and assigned to best-effort traffic. The latter is fixed length and allocated to voice traffic. The location of this slot is fixed at the end of the TV-TDMA frame to reduce voice jitter.

⁴To provide future support for multicast, stations logically AND these four bits with their station id (valid station ids are 0x01, 0x02, 0x04 and 0x08). A non-zero result means a given station is the one addressed

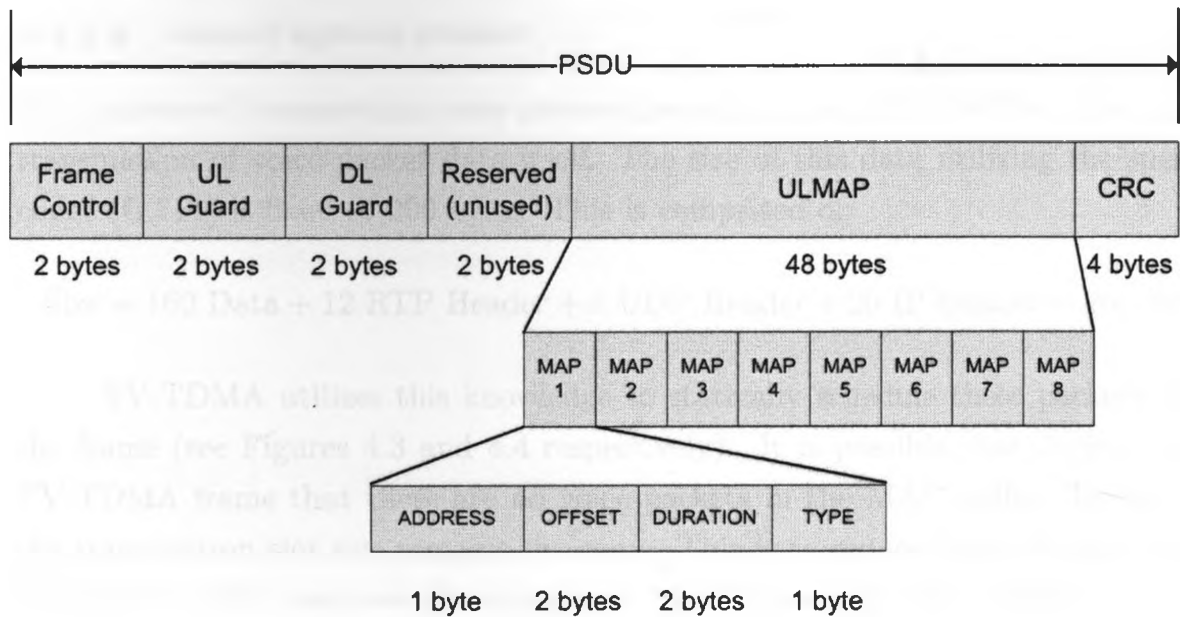

Figure 4.6: Beacon Packet

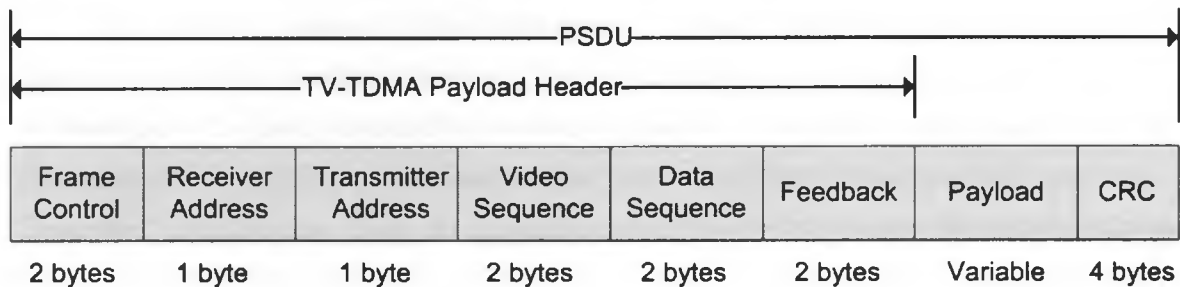

Figure 4.7: Payload Header

4.2.2.2 Payload Packets

All payload packets (Video, Voice and Best-Effort) utilize the MAC payload header in Figure 4.7. This header contains both the transmitter and receiver address, ARQ data and optional feedback. Following the MAC header is the data payload. Also, the MAC packet has an automatically appended⁵ 4 byte CRC field at the tail end of the packet.

⁵This field is automatically appended to the payload in the optional hardware implementation

4.2.2.3 Voice Payload Packet

The purpose of transmitting voice payload packets is two-fold. The first reason is the transmission of voice packet data itself. The size of this data utilizing the specified codec (G.711) is fixed to 200 bytes. This is comprised of:

$$\text{Size} = 160 \text{ Data} + 12 \text{ RTP Header} + 8 \text{ UDP Header} + 20 \text{ IP Header} = 200 \text{ bytes}$$

TV-TDMA utilizes this knowledge to statically schedule these packets within the frame (see Figures 4.3 and 4.4 respectively). It is possible that during a given TV-TDMA frame that there are no voice packets in the MAC buffer. In this case, the transmission slot size remains the same. This is to reduce jitter of voice packets destined for other stations. For this reason, the length of the TV-TDMA superframe should be no larger than the packet generation rate of the voice codec (or 20ms) and should be an even fraction of the generation rate (e.g., 20ms, 10ms, 5ms).

The second reason is that the voice payload header is used to exchange feedback information to the stations. The access point utilizes the *Data Sequence* field to feedback the last successful best-effort packet received in sequence for the ARQ mechanism. Subscribing stations utilize both the *Data Sequence* field and the *Video Sequence* field to relay back the last successfully received packet in sequence to the AP for both best-effort and video respectively. Voice packets do not contain a sequence number as there is no retransmission or acknowledgment of voice packets due to their real-time requirements.

In addition to ARQ feedback, subscribing stations also provide feedback on the length of time required to transmit its entire best-effort buffer in the *Feedback* field. The value of this field is:

$$\text{Feedback} = \min(65535, \text{Time_in_microseconds_to_transmit_buffer})$$

4.2.2.4 Video Payload Packet

Downlink video traffic is sent as a video payload. For these packets, the *Video Sequence* field is used with an incrementing sequence number to denote the packet id for ARQ operation. The AP maintains a separate sequence for each subscribing station video stream.

4.2.2.5 Best-Effort Payload Packet

Any traffic that does not fall within the constraints of the downlink video or uplink/downlink voice is termed best-effort. The allotment for these packets is low priority and is again scheduled by the MAC allocation scheme described later. The *Data Sequence* field is used with an incrementing sequence number to denote the packet id for ARQ operation. The AP also maintains a separate sequence for each subscribing station best-effort packets.

4.2.3 Association

Association/Re-Association in TV-TDMA is handled inherently by its implementation. As TV-TDMA is designed for a fixed point implementation and the set of subscriber stations is assigned statically to the access point, there is no need for an association mechanism in TV-TDMA. Association is done statically when the network is first configured. Each station has a host and network id. All stations in the local network (including the access point) share the network id, while the access point is assigned the host id of 0 and subscriber stations are assigned ids 1 – 4. Eliminating the need of an association scheme via proper initial configuration allows the entire TV-TDMA frame to be contention-free in that no station must request association with the access point.

4.2.4 MAC Scheduling Scheme

The MAC allocation scheme follows a series of steps to allocate the frame. Following any step, if the entire frame is allocated, the process exits. The allocation scheme does not determine the transmission sequence of the packets, alternatively it determines a) which packets are processed on the downlink; and b) the slot times allocated for uplink to each subscribing station. The steps for the allocation process are:

1. Determine the amount of transmission time in the frame $Frame_Time - Beacon - Upguard - Downguard$.
2. Allocate time required for transmission of all voice packets and their interpacket guard time.
3. Allocate Video ARQ buffer. These are video packets requiring retransmission.

4. Allocate Best-Effort ARQ buffer. These are best-effort class packets requiring retransmission.
5. Allocate newly arrived Video packets (see Section 4.2.4.1)
6. Allocate uplink and downlink best-effort packets (see Section 4.2.4.2)

4.2.4.1 Video Packet Allocation

Once voice and retransmitted packets are allocated, a video packet allocation scheme is used. As all other services are classified as best-effort, the video packet allocation scheme is exhaustive. This means that video packets are allocated until either a) the

Algorithm 1 Video Packet Allocation Scheme

```

1:  $\tau \leftarrow \text{Time\_Remaining\_for\_Allocation\_In\_This\_Frame}$ 
2:  $\delta \leftarrow \text{Interpacket\_Guardtime}$ 
3:  $\beta_i \leftarrow \text{Number\_of\_Packets\_in\_Video\_Queue\_for\_Station\_}i, i \in \{1, 2, 3, 4\}$ 
4:  $\gamma_i \leftarrow 0, i \in \{1, 2, 3, 4\}$ 
5: while  $\gamma_i \neq \beta_i$ , for any  $i$  do
6:    $S = \{s_i\} = \arg \min_j \left( \frac{\gamma_j}{\beta_j} \right)$ 
7:    $\varepsilon = |S|$ 
8:    $k = \xi, \xi \in S, \Pr[\xi = s_i] = \frac{1}{\varepsilon}$ 
9:   if  $\gamma_k \neq \beta_k$  then
10:     $P = \text{nextPacket}(k)$  // Next Packet in Queue  $k$ 
11:     $t = \text{TXTime}(P)$ 
12:    if  $t \leq \tau$  then
13:       $\text{SchedulePacket}(k)$ 
14:       $\tau = \tau - t - \delta$ 
15:       $\gamma_k = \gamma_k + 1$ 
16:    else
17:       $\gamma_k = \beta_k$  // No Time Remaining to Allocate Packet  $P$ 
18:    end if
19:  else
20:    return // No More Packets Can Be Allocated
21:  end if
22: end while

```

entire frame is allocated or b) all video transmission queues have been exhausted. Condition (a) is reached when the transmission time of the next packet in any video queue destined for a station is greater than the remaining time available for allocation.

In order to determine which packets are allocated to the given frame. A proportional fair access scheme is used where the number of packets allocated to each station is proportional to the number of video packet enqueued to the station of interest. The algorithm is explained in Algorithm 1.

4.2.4.2 Best-Effort Packet Allocation

Once all other traffic has been allocated, newly arrived best-effort traffic is scheduled. This only occurs if all possible video packets have been allocated. The remaining time to be allocated is split between uplink and download traffic subject to a predefined downlink-uplink ratio. This ratio can be specified to the suit the needs of the particular design criterion.

To avoid over allocation of uplink best-effort traffic, subscribing stations provide feedback to the AP in the header of their voice traffic on the amount of time required to transmit their entire best-effort buffer. Note that this feedback does not contain the amount of channel time required to transmit the ARQ buffer, as acknowledgement feedback is provided to stations in the next frame.

With this information, the access point will allocate the maximum amount of channel time requested subject to fair-share, and available channel time. The allocation scheme is described in detail in Algorithm 2.

Once uplink slot times have been allocated to each uplink station, the AP determines the slot location in the frame and encodes these uplink slot locations and durations into the ULMAP for transmission in the Beacon packet.

4.2.5 ARQ Mechanism

Error control in TV-TDMA is handled by a Go-Back-N type ARQ mechanism. This allows support for segmentation of the superframe into independent downlink and uplink slots. In this ARQ mechanism, packet are assigned a sequence number based on the order transmitted. Receiving stations maintain a log of the last successful packet sequence number. If the next received packet is not the next number in the sequence, the receiving station will assume that a packet loss has occurred and disregard any other packets of that type. When a station provides feedback to the transmitter, it will acknowledge the sequence number of the last packet received in sequential

Algorithm 2 Best-Effort Packet Allocation Scheme

```

1:  $\tau \leftarrow \text{Time\_Remaining\_for\_Packet\_Allocation}$ 
2:  $\delta \leftarrow \text{Interpacket\_Guardtime}$ 
3:  $\eta \leftarrow \text{Downlink\_Ratio}$ 
4:  $\chi_i \leftarrow \text{Uplink\_Time\_Requested\_By\_Station\_i}$ 
5:  $S = \{1, 2, 3, 4\}$  // Set of Uplinks That Remain to be Allocated
6:  $\lambda = \eta\tau$  // Time Available for Downlink Allocation
7:  $\mu = (1 - \eta)\tau/4$  // Fair-share Time Available per Station for Uplink
8: for  $j = 1$  to 4 do
9:   if  $\chi_j \leq \mu$  then
10:     $\text{Allocate\_Time\_to\_STA}(\chi_j, j)$  // Allocate Time to Station
11:     $\tau = \tau - \chi_j$ 
12:     $S = S \setminus \{j\}$  // Remove Station  $j$  from Unallocated Uplinks
13:   end if
14: end for
15:  $\beta_i \leftarrow \text{Number\_of\_Packets\_in\_BestEffort\_Queue\_for\_Station\_i}, i \in \{1, 2, 3, 4\}$ 
16:  $\gamma_i \leftarrow 0, i \in \{1, 2, 3, 4\}$ 
17:  $W = \{1, 2, 3, 4\}$ 
18: while  $\gamma_i \neq \beta_i$ , for any  $i$  do
19:    $\S \subset W, j \in W, \frac{\gamma_j}{\beta_j} < 1$ 
20:    $\varepsilon = |\S|$ 
21:    $k = \xi, \xi \in \S, \S = \{s_i\}, \Pr[\xi = s_i] = \frac{1}{\varepsilon}$ 
22:    $P = \text{nextPacket}(k)$  // Next Packet in Queue  $k$ 
23:    $t = \text{TXTime}(P)$ 
24:   if  $t \leq \lambda$  then
25:     $\text{SchedulePacket}(k)$ 
26:     $\lambda = \lambda - t - \delta$ 
27:     $\gamma_k = \gamma_k + 1$ 
28:   else
29:     $\gamma_k = \beta_k$  // No Time Remaining to Allocate Packet  $P$ 
30:   end if
31: end while
32:  $\tau = \tau + \lambda$  // Utilize Any Unallocated Downlink Time
33:  $\varphi = |S|$ 
34:  $\Phi = \frac{\tau}{\varphi}$  // Split Remaining Time Among Unallocated Stations
35: for all  $j \in S$  do
36:    $\text{Allocate\_Time\_to\_STA}(\Phi, j)$ 
37: end for

```

order. The transmitting station must then retransmit all packets transmitted after that sequence number.

In TV-TDMA, sequence numbers are segmented by station and by traffic type. Both video and best-effort packets maintain independent ARQ queues. In addition, the access point maintains a separate set of sequence number for each destination station. As previously explained, sequence numbers are stored in the specific header field of the video and best-effort packets and acknowledgment feedback is provided in the header of voice packets.

4.3 Performance Results

In this section, the performance of the proposed scheme is evaluated. Results are compared versus the existing 802.11 EDCF protocol. The scenario used for comparison is the one presented in Section 4.1.3.1 with voice, video and best-effort services provided to each station. Parameters from Tables 4.2 and 4.3 are used with additional parameters for TV-TDMA summarized in Table 4.7.

Table 4.7: TV-TDMA Parameters

Parameter	Value	Parameter	Value
Uplink Guard	200 μ s	Downlink Guard	200 μ s
Inter-station Uplink Guard	50 μ s	TV-TDMA Beacon Period	10ms
Physical Layer Used	802.11a	Downlink Ratio	0.66

4.3.1 Video Performance

The jitter performance of the video streams for both protocols is shown for the first and third video streams in Figures 4.8 and 4.9 respectively (Stations 2 and 4 are not shown for brevity). The difference in profile of TV-TDMA from EDCF is a result of the frame based structure of the scheme. This is because in TV-TDMA, a packet arriving during a frame will not have the opportunity to be transmitted until the following frame. For this reason, the TV-TDMA PDFs have two large peaks separated in distance approximately by the length of the frame (10ms). EDCF

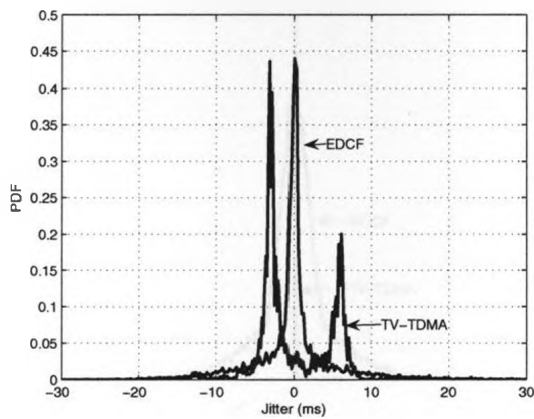

Figure 4.8: Video Jitter of Station 1

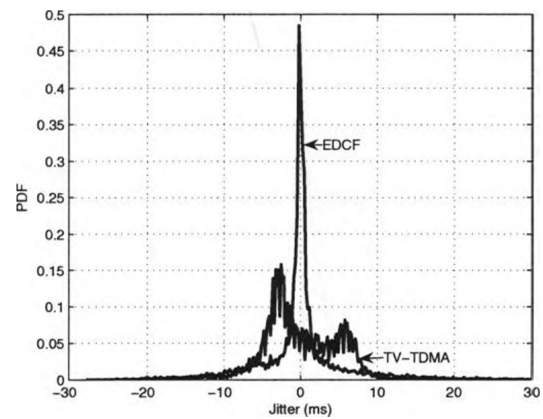

Figure 4.9: Video Jitter of Station 3

however has the jitter profile centered around the origin (or 0ms). From these graphs it is unclear which protocol offers better performance.

Table 4.8 provides more detailed statistics on this performance. It shows that

Table 4.8: TV-TDMA Video Stream Frame Statistics

Station Number:	1	2	3	4
Number of Transmitted Frames:	15000	15000	14994	14999
	<u>EDCF</u>			
Successfully Received Frames:	14535	14543	14535	14548
Unsuccessful Frames:	465	457	459	451
Minimum Frame Delay (ms):	0.09	0.09	0.10	0.10
Maximum Frame Delay (ms):	117.7	117.8	117.5	126.7
Avg. Frame Delay (ms):	11.67	11.72	11.76	11.82
Standard Deviation of Frame Delay:	23.73	23.80	23.82	24.00
	<u>TV-TDMA</u>			
Received Frames:	15000	15000	14994	14999
Dropped Frames:	0	0	0	0
Minimum Frame Delay (ms):	0.5	1.2	1.98	3.3
Maximum Frame Delay (ms):	32.7	33.68	38.76	37.97
Avg. Frame Delay (ms):	6.28	7.71	9.35	10.72
Standard Deviation of Frame Delay:	3.13	3.22	3.37	3.24

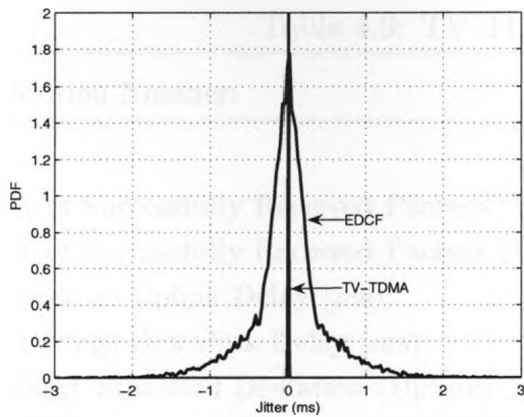

Figure 4.10: Voice Downlink Jitter for Station 4

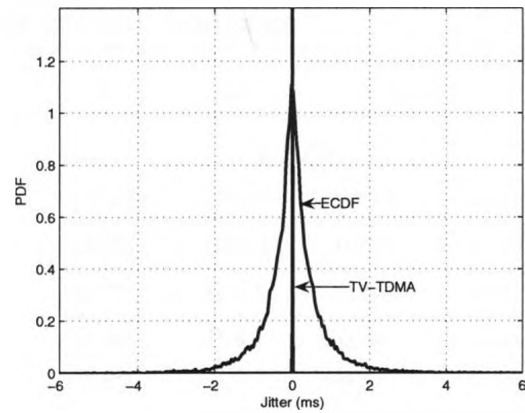

Figure 4.11: Voice Uplink Jitter for Station 4

TV-TDMA is able to provide more bounded delay for the variable bitrate video. This is clear by observing both the variation in delay (through the maximum/minimum delay) as well as the large difference in the delay standard deviation. Although EDCF is able to offer a lower minimum delay, the upper delay bound is a factor of 4 larger than TV-TDMA. Additionally, TV-TDMA is able to offer a better successful delivery percentage of video frames.

4.3.2 Voice Performance

The performance of the voice streams is also an important measure when comparing both schemes. The jitter performance for a station's downlink voice is shown in Figure 4.10 and the uplink voice in Figure 4.11. Performance of additional stations is similar and not shown for brevity. These graphs show much better performance for the TV-TDMA scheme. This is due to the fixed scheduling of voice packets within the TV-TDMA frame resulting in negligible jitter for voice irrespective of other traffic levels. Additional statistics for all stations is presented in Table 4.9. From this, the trade-offs associated with each scheme are clear. The individual packet delay for uplink in TV-TDMA is much higher than the downlink delay and that of EDCF. This is due to the packet being transmitted at the end of the frame. This amount of delay however is still acceptable as the variation in delay is negligible.

Table 4.9: TV-TDMA Voice Stream Statistics

Station Number:	1	2	3	4
	<u>EDCF</u>			
% of Successfully Received Packets (Uplink):	100%	100%	100%	100%
% of Successfully Received Packets (Downlink):	100%	100%	100%	100%
Average Uplink Delay (ms):	0.59	0.73	0.60	0.61
Average Downlink Delay (ms):	0.40	0.42	0.53	0.44
Delay Standard Deviation (Uplink):	0.62	0.72	0.56	0.56
Delay Standard Deviation (Downlink):	0.31	0.33	0.38	0.36
	<u>TV-TDMA</u>			
% of Successfully Received Packets (Uplink):	98.98%	98.92%	99.10%	99.07%
% of Successfully Received Packets (Downlink):	99.04%	98.98%	98.89%	99.00%
Average Uplink Delay (ms):	9.50	9.60	9.71	9.83
Average Downlink Delay (ms):	0.213	0.277	0.341	0.406
Delay Standard Deviation (Uplink):	0	0	0	0
Delay Standard Deviation (Downlink):	0	0	0	0

Regarding packet success rates, as TV-TDMA does not support retransmission of voice traffic due to its time-sensitivity, the packet success rate is less than EDCF.

4.3.3 Best-Effort Performance

Finally, observations are done on the best-effort stream in this scenario. The delay PDFs for Station 3's downlink and uplink best-effort streams is shown in Figures 4.12 and 4.13 respectively.

These Figures show that the delay performance for best-effort data is better for EDCF than TV-TDMA. This is a result of TV-TDMA using an exclusive priority scheme for video traffic, versus the preferred priority in EDCF by use of the configured window sizes. TV-TDMA however is able to take advantage of segments of lower bitrate video to offer improved overall throughput for these best-effort services. This is shown in Table 4.10 where the best-effort throughput for the downlink in TV-TDMA is nearly twice the available throughput for EDCF. The uplink best-effort datarate for both schemes is the same as these stations were not under saturation.

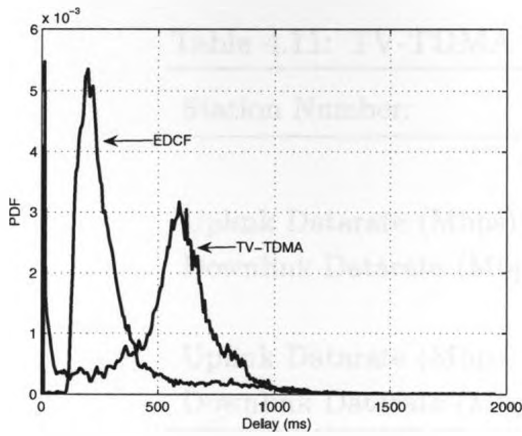

Figure 4.12: Downlink Best-Effort Delay PDF - Station 3

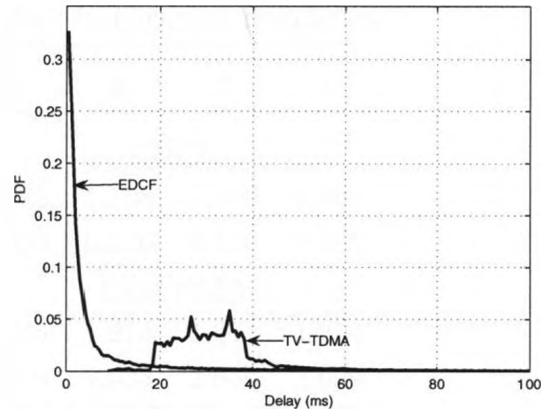

Figure 4.13: Uplink Best-Effort Delay PDF - Station 3

Table 4.10: TV-TDMA Best-Effort Throughput Statistics

Station Number:	1	2	3	4
	<u>EDCF</u>			
Uplink Datarate (Mbps):	1.000	1.000	1.000	1.000
Downlink Datarate (Mbps):	1.167	1.121	1.742	1.689
	<u>TV-TDMA</u>			
Uplink Datarate (Mbps):	1.00	1.000	1.000	1.000
Downlink Datarate (Mbps):	2.602	2.605	2.606	2.603

4.3.4 Best-Effort Saturation Rates

To observe that maximum throughput of best-effort for both these schemes, the configured best-effort datarate is increased for both downlink and uplink to 5Mbps. The saturation throughput for this case is shown in Table 4.11. As shown the combined uplink and downlink throughput for TV-TDMA is nearly twice that of EDCF. In addition, the dynamic allocation scheme allows the protocol to perform some admission control on the allowed best-effort flow. This allows the system to provide appropriate relations between the uplink and downlink achievable rates. This is needed as end users frequently require less uplink than downlink traffic. The results from EDCF demonstrate that under saturation, the distributed protocol does not tend to these needs.

Table 4.11: TV-TDMA Best-Effort Saturation Statistics

Station Number:	1	2	3	4
	<u>EDCF</u>			
Uplink Datarate (Mbps):	1.775	1.708	1.686	1.691
Downlink Datarate (Mbps):	0.520	0.526	0.576	0.865
	<u>TV-TDMA</u>			
Uplink Datarate (Mbps):	1.275	1.274	1.274	1.274
Downlink Datarate (Mbps):	2.640	2.633	2.650	2.629

4.4 Protocol Remarks

In this Chapter, the TV-TDMA MAC protocol for use in point-to-multipoint networks has been proposed. This work has shown that the use of a TDMA-based MAC scheme can improve system performance by eliminating time wasted by during idle slots and during collisions.

The proposed scheme has shown to improve delay and jitter performance of both video and voice versus the existing EDCF scheme. This is accomplished via a dynamic packet allocation scheme which uses knowledge of the buffered video streams to dynamically design transmission schedules during each frame. Furthermore, under saturation conditions, the protocol has shown to provide better admission control of best-effort data packets in order to provide more designer flexibility during implementation.

Chapter 5

Conclusion

In order to ensure successful operation of wireless local area networks, the need for medium access control schemes is clear. As performance requirements increase, as does the resulting research in methods of offering improved performance.

As shown in this thesis, improvements on MAC schemes can be accomplished in a number of ways. One such method is to improve the MAC layer data transfer rate. In this thesis a novel contribution was made in the development of a MIMO-Aware MAC scheme that utilizes MIMO antenna systems to allow multiple stations to simultaneously schedule data transmission. This effectively improved the overall network throughput and reduced the amount of packet delay.

Another such method is to provide better handling of different traffic types, such as video and voice. The work in this thesis analyzed the existing protocols for handling service differentiation and found that there are a large amount of wasted resources when used in a point-to-multipoint network. In addition, these existing schemes were unable to meet real-time service requirements when faced with variable bitrate video. A new TDMA-based scheme was then proposed to reduce overhead and dynamically schedule packets. The TV-TDMA scheme was shown capable of improving the networks capability of handling these real-time services.

5.1 Future Research Work

Furthering improvements to the MAC are possible. With demand increasing each day, the need for more efficient MAC protocols is a priority. One such possible direction in offering better MAC performance is examining methods of achieving the capacity offered by MIMO channels. In this work, the ability of MIMO to offer major improvements in throughput have been demonstrated. Methods of achieving this capacity and development the respective hardware is still an open issue in the community.

In continuing work, evaluation of proposed protocols in a hardware test-bed will also be performed. This work will make use of commodity 802.11x based hardware in conjunction with the open-source MADWIFI [36]. This will provide more accurate performance results without design of customized hardware.

References

- [1] *International Standard [for] Information Technology - Telecommunications and information exchange between systems-Local and metropolitan area networks - Specific Requirements - Part 11: Wireless LAN Medium Access Control (MAC) and Physical Layer (PHY) specifications*, 1999th ed., IEEE 802.11 WG, Reference number ISO/IEC 8802-11: 1999 (E) IEEE STD 802.11, 1999.
- [2] D-Link Corporation, "D-Link Canada," ONLINE, <http://www.dlink.ca>.
- [3] Cisco Systems, "Linksys: A Division of Cisco Systems," ONLINE, <http://www.linksys.com/>.
- [4] Netgear, "Netgear," ONLINE, <http://www.netgear.com/>.
- [5] Logitech, "diNovo Mini," ONLINE, <http://www.logitech.com/index.cfm/keyboards/keyboard/devices/3848>.
- [6] HP, "HP Jetdirect ew2400," ONLINE, <http://h10010.www1.hp.com/wwpc/us/en/sm/WF05a/18972-18972-236253-34210-396578-408888.html>.
- [7] Bluetooth SIG, Inc., "The Official Bluetooth Technology Info Site," ONLINE, <http://www.bluetooth.com/>.
- [8] Wi-Fi Alliance, "Wi-Fi Alliance Home Page," ONLINE, <http://www.wi-fi.org/>.
- [9] M. M. Group, "World internet users: December 2007," ONLINE, available: <http://www.internetworldstats.com/stats.htm>.
- [10] S. McCanne and S. Floyd, "ns Network Simulator," ONLINE, available: <http://www.isi.edu/nsnam>.
- [11] Y. Xiao, "IEEE 802.11n: Enhancements for Higher Throughput in Wireless LANs," *IEEE Wireless Communications Magazine*, vol. 12, no. 6, Dec. 2005.
- [12] Linksys: A Division of Cisco Systems, "Wireless-N Broadband Router," ONLINE, <http://www.linksys.com/>.
- [13] D-Link Canada, "DIR-655 Xtreme N Gigabit Router," ONLINE, <http://www.dlink.ca/>.
- [14] C. E. Shannon, "A Mathematical Theory of Communication," *Bell System Technical Journal*, vol. 27, pp. 379–423 and 623–656, July and October 1948.

-
- [15] A. Paulraj, R. Nabar, and D. Gore, *Introduction to Space-Time Wireless Communications*. Cambridge University Press, 2003.
- [16] E. Telatar, “Capacity of Multi-Antenna Gaussian Channels,” *AT&T-Bell Labs Internal Tech. Memo*, June 1995.
- [17] J. Park, A. Nandan, M. Gerla, and L. Heecheon, “SPACE-MAC: Enabling Spatial Reuse Using MIMO Channel-Aware MAC,” *IEEE ICC 2005*, 2005.
- [18] J. C. Mundarath, P. Ramanathan, and B. D. V. Veen, “NULLHOC: A MAC Protocol for Adaptive Antenna Array Based Wireless Ad Hoc Networks in Multipath Environments,” *IEEE GLOBECOM 2004*, 2004.
- [19] *Information technology Generic Coding of Moving Pictures and Associated Audio Information*, ISO/IEC 13818-1:1996, 1996.
- [20] S. Harada, Y. Hamamoto, Y. Ohta, and M. Nishino, “Development of Audio and Video Synchronous Transmission System Based on IEEE802.11a,” *Consumer Communications and Networking Conference*, pp. 316–319, January 2004.
- [21] “ffmpeg,” ONLINE, available: <http://ffmpeg.mplayerhq.hu>.
- [22] “Monarch Project: Rice Monarch Extensions to ns-2,” ONLINE, available: <http://www.monarch.cs.rice.edu/cmu-ns.html>.
- [23] R. J. Punnoose, P. V. Nikitin, and D. D. Stancil, “Efficient Simulation of Rician Fading Within a Packet Simulator,” *Proc. Vehicular Technology Conf.*, vol. 2, pp. 764–767, 2000.
- [24] S. Wiethölter and C. Hoene, “Design and Verification of an IEEE 802.11e EDCF Simulation Model in ns-2.26,” *TKN-03-19 Technical Report Series*, November 2003.
- [25] C. Cicconetti, L. Lenzini, E. Mingozzi, and G. Stea, “A Software Architecture for Simulating IEEE 802.11e HCCA,” *IPS-MoMe*, March 2005.
- [26] J. Klaue, B. Rathke, and A. Wolisz, “EvalVid - A Framework for Video Transmission and Quality Evaluation,” *In Proc. of the 13th International Conf. on Modelling Techniques and Tools for Computer Performance Evaluation*, September 2003.
- [27] M. Park, C. Soon-Hyeok, and S. M. Nettles, “Cross-Layer MAC Design for Wireless Networks Using MIMO,” *IEEE GLOBECOM*, 2005.
- [28] M. Park, R. W. Heath, and S. M. Nettles, “Improving Throughput and Fairness for MIMO Ad Hoc Networks Using Antenna Selection Diversity,” *IEEE GLOBECOM*, 2004.

-
- [29] C. Doerr, M. Neufeld, J. Filfield, T. Weingart, D. C. Sicker, and D. Grunwald, "MultiMAC - An Adaptive MAC Framework for Dynamic Radio Networking," *In Proc. IEEE DySPAN*, November 2005.
- [30] M. Neufeld, J. Fifield, C. Doerr, A. Sheth, and D. Grunwald, "SoftMAC - Flexible Wireless Research Platform," *In HotNets-IV*, November 2005.
- [31] A. Sharma, M. Tiwari, and H. Zheng, "MadMAC: Building a Reconfigurable Radio Testbed Using Commodity 802.11 Hardware," *In Proc. IEEE SECON 2006 Workshop*, September 2006.
- [32] Rogers Communications Inc., "Rogers Home Page," ONLINE, <http://www.rogers.com>.
- [33] Cogeco Cable Inc., "Cogeco," ONLINE, <http://www.cogeco.ca/>.
- [34] *International Standard [for] Local and Metropolitan Area Networks - Part 16: Air Interface for Fixed Broadband Wireless Access Systems*, 2004th ed., IEEE 802.16 WG, IEEE STD 802.16-2004, 2004.
- [35] *Suppliment to IEEE Standard for Information Technology - Telecommunications and information exchange between systems-Local and metropolitan area networks - Specific Requirements - Part 11: Wireless LAN Medium Access Control (MAC) and Physical Layer (PHY) specifications. High-speed Physical Layer in the 5GHz Band*, 1999th ed., IEEE 802.11 WG, Reference number ISO/IEC 8802-11: 1999/Amd 1:2000(E) IEEE STD 802.11a-1999(R2003), 1999.
- [36] "MADWIFI: Multiband Atheros Driver for Wireless Fidelity," ONLINE, <http://www.madwifi.org/>.

Appendix A

Packet Overhead Calculations for 802.11a

The calculation of transmission time for a packet using 802.11a is divided into three components: PLCP Preamble, SIGNAL symbol and the coded symbol (containing the data). Defining the various quantities, the transmission time can be expressed as:

$$T_{TX} = T_{PREMABLE} + T_{SIGNAL} + T_{CODED} \quad (\text{A.1})$$

Both $T_{PREMABLE}$ and T_{SIGNAL} are defined in the 802.11a specifications and are equal to $16\mu\text{s}$ and $4\mu\text{s}$ respectively. The transmission time for T_{CODED} is dependant on the size of the data packet as well datarate. In addition, 802.11a requires that the number of bits contained in the data portion of the coded symbol is a multiple of the number of data bits encoded per symbol. For a 54Mbps datarate, this is 216 bits. In order to achieve this, pad bits are added to the tail end of the packet. The number of pad bits depends on the length of data. In these calculations, the number of pad bits is assumed to be zero which provides a lower bound on the transmission time (thus a lower bound on the percentage overhead) of the coded symbol for an arbitrary data packet.

Defining the size of a data packet as X in bytes, the transmission time at 54Mbps of the coded symbol is (derived from the specifications):

$$T_{CODED} = \frac{OVERHEAD + 8X + 22}{54 \times 10^6} \quad \text{seconds} \quad (\text{A.2})$$

Where the $OVERHEAD$ denotes the MAC, IP and RTP overhead. If the packet only attaches 802.11 MAC headers to the packet, $OVERHEAD = 24 \times 8$ bits. The resulting expression for transmission time of the coded symbol becomes:

$$T_{CODED} = \frac{214 + 8X}{54 \times 10^6} \quad \text{seconds} \quad (\text{A.3})$$

Finally, in order to find the percentage of overhead, the transmission time of the data packet alone must be computed. This is given as:

$$T_{DATA} = \frac{8X}{54 \times 10^6} \quad \text{seconds} \quad (\text{A.4})$$

Using (A.3) and (A.4), the physical layer overhead as a percentage for a given data packet size is:

$$\eta = \left(1 - \frac{\frac{8X}{54 \times 10^6}}{\frac{214+8X}{54 \times 10^6} + 20 \times 10^{-6}} \right) \times 100\% \quad (\text{A.5})$$

Applying (A.5) to the example in Chapter 2 of a 188 byte MPEG2-TS packet, the percentage of overhead is:

$$\eta = \left(1 - \frac{\frac{8 \times 188}{54 \times 10^6}}{\frac{214+8 \times 188}{54 \times 10^6} + 20 \times 10^{-6}} \right) \times 100\% = 46.2\% \quad (\text{A.6})$$