

Electronic Thesis and Dissertation Repository

6-16-2011 12:00 AM

Contextual control of orienting eye-head gaze shifts in the monkey

Brendan B. Chapman, *University of Western Ontario*

Supervisor: Dr. Brian D. Corneil, *The University of Western Ontario*

A thesis submitted in partial fulfillment of the requirements for the Doctor of Philosophy degree in Neuroscience

© Brendan B. Chapman 2011

Follow this and additional works at: <https://ir.lib.uwo.ca/etd>



Part of the [Behavior and Behavior Mechanisms Commons](#)

Recommended Citation

Chapman, Brendan B., "Contextual control of orienting eye-head gaze shifts in the monkey" (2011). *Electronic Thesis and Dissertation Repository*. 184.
<https://ir.lib.uwo.ca/etd/184>

This Dissertation/Thesis is brought to you for free and open access by Scholarship@Western. It has been accepted for inclusion in Electronic Thesis and Dissertation Repository by an authorized administrator of Scholarship@Western. For more information, please contact wlsadmin@uwo.ca.

Contextual control of orienting eye-head gaze shifts in the monkey

(Spine title: Neuromuscular control of orienting head movements)

(Thesis format: Integrated-Article)

by

Brendan B. Chapman

Graduate Program in Neuroscience

A thesis submitted in partial fulfillment
of the requirements for the degree of
Doctorate of Philosophy

The School of Graduate and Postdoctoral Studies
The University of Western Ontario
London, Ontario, Canada

© Brendan B. Chapman 2011

THE UNIVERSITY OF WESTERN ONTARIO
SCHOOL OF GRADUATE AND POSTDOCTORAL STUDIES

CERTIFICATE OF EXAMINATION

Supervisor

Dr. Brian Corneil

Supervisory Committee

Dr. Stefan Everling

Dr. Jody Culham

Examiners

Dr. Stephen Lomber

Dr. Tutis Vilis

Dr. Ewan MacPherson

Dr. Neeraj Gandhi

The thesis by

Brendan Blair Chapman

entitled:

Contextual control of eye-head gaze shifts in the monkey

is accepted in partial fulfillment of the
requirements for the degree of
Doctor of Philosophy

Date _____

Chair of the Thesis Examination Board

Abstract

Vision is one of the principal methods used by primates to acquire information about the surrounding environment. As a result, both humans and monkeys have a highly evolved oculomotor system that functions to rapidly relocate the line of sight to areas of interest. These orienting movements are called gaze shifts. Gaze shifts commonly include the coordinated movement of the eyes-in-head and the head-in-space. This thesis examines the muscular and neural control of orienting head movements.

The contextual control of behavior is important as it allows one to act appropriately in response to different situations. A common task used to examine the contextual control of behavior is the pro- and anti-saccade task. Pro-saccades simply require a subject to look towards a stimulus. Anti-saccades require a subject to inhibit a movement towards a stimulus in favor of a volitional movement to the diametrically opposite position. This task can reveal capabilities of the oculomotor system and its response to varying behavioral states. To understand the neuromuscular control of orienting head movements during various tasks, we recorded the electromyographic (EMG) activity in ten neck muscles that can orient the head either horizontally or vertically. Recording neck EMGs provides an objective and precise measurement of the neural signals received by neck muscles, circumventing some of the structural and biomechanical complexities of head motion.

Chapter two examines neck muscle activity in a pro- and anti-saccade task. Many neural areas and certain neck muscles become active in response to the presentation of a visual stimulus. This visual response on the neck muscles can result in a head turning

synergy that orients the head towards the stimulus. By dissociating the typical stimulus-response paradigm, we can analyze if and how the bottom-up visual activity changes in relation to different contexts. A number of cortical and subcortical areas are involved in the generation of correct anti-saccades. By combining EMG recordings while subjects perform this task, we can examine whether top-down task-related activity is present in the neck muscles. This experiment could reveal flexibility in the eye-head gaze shift system that has previously gone unreported.

Chapter three will elucidate the supplementary eye field's (SEF) role in the control of orienting eye-head gaze shifts. Neck EMG activity was recorded while providing electrical microstimulation to the SEF in a pro-saccade task. Combining EMGs and SEF stimulation permits the systematic examination of cephalomotor commands during head-restrained and head-unrestrained orienting eye-head gaze shifts. The evoked activity of EMGs could reveal functional properties of the neural circuitry between the SEF and the motor related neurons responsible for eye and head movements. The timing and metrics of evoked EMG activity and eye-head gaze shifts are consistent with other frontal areas suggesting a functional role of the frontal cortex in influencing eye-head gaze shifts.

Chapter four will combine EMG recordings with SEF stimulation during a pro- and anti-saccade task. The SEF is thought to serve as an interface between high-level cognitive control of gaze shifts and low-level activity associated with the production of saccades. As will be described later in the thesis, neck muscles demonstrate top-down task related activity during anti-saccades. The SEF is a likely candidate for the generation of task-dependent signals observed during anti-saccades. By combining SEF

stimulation and neck EMGs in an anti-saccade task, we can reveal if neck muscle activity is modulated by the behavioral task.

In summary, this thesis identifies three central themes concerning orienting eye-head gaze shifts. First, chapter two emphasizes the complex interaction of sensori-motor processes in orienting head movements. Second, chapter three attests to the consistent nature of certain areas in frontal cortex and their impact on eye-head gaze shifts. Finally, chapter four demonstrates a potential candidate for influencing the contextual control of cephalomotor commands. Combined, these results highlight the complex interactions of sensori-motor transformations in the motor periphery and emphasize the parallel nature of information processing during the contextual control of eye-head gaze shifts.

Key words

Saccade

Eye-head gaze shifts

Non-human primate

Electromyography

Microstimulation

Supplementary eye fields

Pro- and anti-saccade

Neck muscles

Oculomotor control

Sensori-motor transformations

Co-authorship

Brendan B. Chapman M.Sc., Michael A. Pace M.Sc., Sharon Cushing MD, Brian D. Corneil Ph.D.

As the author of this thesis and the primary author of each manuscript comprising the three experimental chapters, I can attest that I, Brendan Chapman, was the primary contributor at all stages of the described experiments including experimental design, data collection, data analysis and writing of each of the resulting manuscripts. Dr. Brian D. Corneil provided expert advice and supervision pertaining to experimental design and analysis and assisted in the preparation of the manuscripts for this thesis and for publication. M.A. Pace, M.Sc. assisted with data collection described in chapter two. Dr. Sharon Cushing provided technical assistance, providing expertise in implanting the chronically indwelling neck muscle electrodes.

Acknowledgments

First, I would like to offer my sincere gratitude and extend a heart-felt thank you to Brian for guiding me through some very formative years. When I sent Brian the initial e-mail several years ago, I could not foresee how remarkable the next chapter in my life would be. From his nearly infinite patience with me to his good-natured, fun-loving personality, I am proud not only to call Brian an advisor but also a friend. Once again, thank you.

The nature of our research requires exceptional assistance from several people. First, I would like to thank Darren for his support and care of the animals and Sarah for her consultations on all things monkey related. Next, I would like to thank Sharon for her surgical expertise and Kevin for his technical expertise. Finally, I would like to thank Kat for keeping the monkeys healthy and happy and for making the monkey unit a more tolerable workplace.

I would also like to thank all the past and present members of the Corneil Lab. A special thank you goes out to Mike for assisting in data collection. Scott, I will always remember our golf days. What can I say about Jim, Sam and Ben? The many hours we spent in the windowless basement of Robarts Research Institute were made note-worthy with all the games we played and invented (Collicular explosions, the lacrosse ball, flying monkeys etc.). Go Jets Go !!! Thanks to Ben, Mike and Tyler for all computer related help.

A large and well deserved thank you goes out to my parents, Brad and Karen, for their continued support. Whether it be financial or emotional, my parents were always around to help and I do not know how I could have made it through the last few years

without their encouragement and assistance. I would like to also thank the rest of my family and friends for their interest over the years; however, I believe their interest was more in the monkeys than the actual research.

Finally, I would like to thank my finace, Taylor. Words do not do justice to the amount of support and encouragement she has provided over the years. For this, I dedicate my thesis to her.

Table of contents

Certificate of Examination	ii
Abstract	iii
Key words	vi
Co-authorship	vii
Acknowledgment	viii
List of Tables	xv
List of Figures	xvi
List of Appendices	xviii
Abbreviations	xix
<u>CHAPTER 1</u>	<u>1</u>
1.1 General introduction	1
1.2 Saccades: neural circuitry	2
1.3 Concepts of saccade production	6
1.4 Eye-head gaze shifts	12
1.5 Pro- and anti-saccade task as a tool to assess contextual control	17
1.6 Visual responses on neck muscles	20
1.7 SEF and eye-head gaze shifts	21
1.8 Conclusion	23
Reference list	25
<u>CHAPTER 2</u>	<u>37</u>
Abstract	38
2.1 Introduction	39
2.2 Methods	40
2.2.1 Subjects and surgical procedures	40

2.2.2 Training and behavioral paradigm	41
2.2.3 Data collection and processing	44
2.2.4 Data analysis	45
2.3 Results	46
2.3.1 Behavioral assessment of head-unrestrained anti-saccades	46
2.3.2 Neck muscle activity during head-unrestrained anti-saccades	47
2.3.3 Timing and visual response on neck muscles	54
2.3.4 Comparative characteristics of visual response on neck muscles with trial type	59
2.3.5 Emergence of top-down influences on neck EMG activity before stimulus presentation	64
2.3.6 Background neck muscle activity reflects performance on anti-saccade trials	66
2.3.7 Subtle head movements in response to stimulus presentation	67
2.4 Discussion	72
2.4.1 Potential neural circuits mediating bottom-up and top-down aspects of neck muscle recruitment	72
2.4.2 Blurring the sensorimotor transformation for anti-saccades	75
2.4.3 Biomechanical consequences of the visual response on neck muscles	76
2.4.4 Summary	77
Reference list	78

CHAPTER 3	85
Abstract	86
3.1 Introduction	87
3.2 Methods	89
3.2.1 Subjects and surgical procedures	89
3.2.2 Microstimulation parameters	90
3.2.3 Behavioral task and experimental parameters	92
3.2.4 Data collection and analysis	94
3.3 Results	95
3.3.1 Timing and metrics of evoked movements	98
3.3.2 Analysis of neck muscle EMG activity evoked by SEF stimulation	102
3.3.3 Influence of head restraint on evoked neck muscle responses	106
3.3.4 Quantification of evoked neck EMG responses from SEF	109
3.3.5 Timing of evoked neck EMG responses relative to gaze onset	112
3.3.6 Timing and magnitude of evoked neck EMG responses relative to the evoked head movement	118
3.3.7 EMG activity associated with no gaze movements	121
3.3.8 Head movement parameters on stimulation trials without a gaze shift	123
3.3.9 Comparison of volitional vs. evoked movements	126
3.3.10 Evoked neck muscle responses on extensors	127
3.4 Discussion	132
3.4.1 Comparison to previous SEF studies	134
3.4.2 Comparison to previous studies in the oculomotor system	136

3.4.3 Possible pathways	138
3.4.4 Summary	138
Reference list	140
CHAPTER 4	146
Abstract	147
4.1 Introduction	149
4.2 Methods	151
4.2.1 Subjects and surgical procedures	151
4.2.2 Microstimulation parameters	152
4.2.3 Behavioral and experimental parameters	156
4.2.4 Data collection and processing	158
4.3 Results	159
4.3.1 Task specific behavioral effects following short-duration stimulation of the SEF	160
4.3.2 Profile of neck EMG evoked by short-duration SEF stimulation	165
4.3.3 Increased evoked neck EMG activity during the preparation for anti- vs. pro-saccades	168
4.3.4 Task dependent modulation in the post-stimulus period	174
4.4 Discussion	177
4.4.1 Behavioral effects of stimulation	177
4.4.2 Neuromuscular responses to SEF stimulation	178
4.4.3 Contextual control of eye-head gaze shifts	180

4.4.4 Summary	182
Reference list	183
CHAPTER 5	190
5.1 General discussion	190
5.2 Objective One: top-down and bottom-up EMG activity	190
5.3 Objective Two: examining the SEFs role in neuromuscular control	192
5.4 Objective Three: contextual recruitment of neck muscles following SEF stimulation	194
5.5 Implications of our results in sensori-motor transformations	195
5.6 Methodological issues	197
5.7 General limitations	201
5.8 Future directions	202
5.9 Conclusions	204
Reference list	205
Curriculum vitae	212

List of Tables

Table 2-1 Quantification of pro- and anti-saccade metrics	48
---	----

List of Figures

Figure 1-1 Simplified schematic of oculomotor areas	4
Figure 1-2 Simplified schematic of major efferent pathways from the SEF	8
Figure 1-3 Schematic representation of concepts of saccade production	11
Figure 1-4 Schematic of the pro- and anti-saccade task	18
Figure 2-1 Schematic line drawings of implanted neck muscles and pro- and anti-saccade task	42
Figure 2-2 Representation of head-unrestrained neck muscle activity	50
Figure 2-3 Representation of head-restrained and –unrestrained neck muscle activity	53
Figure 2-4 Analysis for determining timing of visual response	56
Figure 2-5 Scatterplots of pro- and anti- saccade discrimination times	60
Figure 2-6 Histograms of the modulation indices of neck muscle activity	62
Figure 2-7 Time course of neck muscle activity	65
Figure 2-8 Normalized EMG activity during the fixation interval	68
Figure 2-9 Eye, head and gaze velocity traces	70
Figure 3-1 Schematic line drawings of implanted neck muscles	91
Figure 3-2 SEF grid locations and plots of evoked movements	97
Figure 3-3 Head contribution, gaze-head lead times and amplitude-velocity main sequence relationships	101
Figure 3-4 Representation of EMG activity	105

Figure 3-5 Scatterplots of peak magnitudes and facilitation latencies	108
Figure 3-6 Scatterplots of timing and magnitudes of EMG activity	111
Figure 3-7 Plots of facilitation latency against latency of evoked gaze shift	114
Figure 3-8 Plots of EMG and gaze latencies	116
Figure 3-9 Plots of EMG and head latencies	120
Figure 3-10 Timing and magnitude of EMG responses on gaze and no-gaze trials	122
Figure 3-11 Dynamics of gaze and no-gaze trials	125
Figure 3-12 Representation and plots of stimulation and control trials	129
Figure 3-13 Representation of EMG activity during vertical gaze shifts	131
Figure 3-14 Plots of various parameters on extensor muscles	133
Figure 4-1 Schematic line drawings of implanted neck muscles and task	154
Figure 4-2 Schematic of sampled SEF locations	155
Figure 4-3 Plots of pro- and anti-saccade RTs	161
Figure 4-4 Plots of pro- and anti-saccade error rates	164
Figure 4-5 Plots of representative EMG activity	167
Figure 4-6 Background and evoked EMG activity during fixation interval	170
Figure 4-7 Population plots of EMG activity during fixation interval	171
Figure 4-8 Background and evoked EMG activity during post-stimulus interval	173
Figure 4-9 Population plots of EMG activity during post-stimulus interval	176

List of Appendices

Appendix 1: Ethics approval

211

Abbreviations

°	degrees
±	plus or minus
μA	microamps
μV	microvolts
BC	biventer cervicis
BG	basal ganglia
cMRF	central mesencephalic reticular formation
CNS	central nervous system
COM	complexus
dIPFC	dorso-lateral prefrontal cortex
EMG	electromyography or electromyographic
FEF	frontal eye fields
Fig	figure
FP	fixation point
Gh	horizontal gaze
Gv	vertical gaze
Hz	hertz
INC	interstitial nucleus of Cajal
iSC	intermediate and deep layers of the superior colliculus
L-	denotes left muscle
LED	light emitting diode

LIP	lateral intraparietal area
ms	milliseconds
MRF	mesencephalic reticular formation
NPRc	nucleus reticularis pontis caudalis
NPRo	nucleus reticularis pontis oralis
NRGc	nucleus reticularis gigantocellularis
OCI	obliquus capitis inferior
P	probability value
PRF	pontine reticular formation
R-	denotes right muscle
RCM	rectus capitis posterior major
riMLF	rostral interstitial nucleus of the medial longitudinal fasciculus
RT	reaction time
S	stimulus
SC	superior colliculus
SEF	supplementary eye fields
SP	splenius capitis
Stim	stimulation
TMS	transcranial magnetic stimulation
U	up
VC	visual cortex
Vs.	versus

Chapter 1

1.1 - General introduction

The scientific study of information processing within the central nervous system (CNS) is one of the primary objectives of neuroscientists. Although many experimental designs are available, a common approach to examining these neural mechanisms is to provide sensory input and measure motor output. These sensori-motor transformations can range from simple responses, such as pressing a button, to more complex responses, such as operating a motor vehicle. Even though we have a large repertoire of motor responses, the focal point of this dissertation will center on the sensori-motor transformation known as the orienting response. A broad range of movements can be classified as ‘orienting responses’; however, one sub-category will be of particular importance for this thesis: the gaze shift. Gaze shifts involve orienting the line of sight to an area or object of interest.

Humans and non-human primates commonly use eye movements to examine their environment. However, the primate retina is not organized in a homogeneous manner. A high concentration of cone photoreceptors are clustered in a small area called the fovea. This specialized area is $\sim 1 \text{ mm}^2$ and is responsible for sharp central vision that is necessary for any activity where visual detail is of primary importance. If images of interest fall outside this region, eye movements can appropriately reposition the image on the fovea. These eye movements are called *saccades*, which are rapid, conjugate movements of both eyes.

Both physical and neural limitations are placed on how far the eye can move. These limits become readily apparent when, holding your head still, you try to look towards an object directly behind you. Eye movements alone can allow you to view $\sim 100^\circ$ of visual angle; however, objects of interest can fall outside of this range. To overcome this problem, we can combine a coordinated movement of the eyes-in-head and the head-in-space to acquire almost any desired object. Although we have a large field-of-view with eye movements only, head movements are often utilized well within the physical limits of the eyes due to neurally imposed restrictions on eye movements (Guitton and Volle 1987). The combination of eye and head movements allows for almost total coverage of the field-of-view except for a small area directly behind the head (Carpenter 1991). To avoid future confusion, I will clarify some nomenclature at this point. Saccades will refer to movement of the eye-in-head only while gaze shifts will refer to a combined movement of the eye-in-head and the head-in-space. Although much research has been conducted on saccades, relatively little is known about orienting head movements and the underlying neuromuscular commands. The goal of this thesis is to examine neck muscle activity associated with gaze shifts, specifically focusing on behavioral (Chapter two) and neural (Chapters three and four) aspects of orienting head movements, and their relationship to gaze shifts.

1.2 - Saccades: neural circuitry

Saccades are rapid, conjugate movements of the eyes that allow for the orientation of the fovea to areas of interest. Saccades can last between 20-200 ms depending on the

amplitude of the movement. Because we are effectively blind during a saccade, an optimum is placed on generating these eye movements as fast as possible. Consequently, saccadic eye movements are one of the fastest movements made by primates, reaching angular speeds of up to 1000 °/s. Saccadic eye movements have been extensively examined over the previous 40 years providing a well-refined understanding of the behaviour and neurophysiology of saccades (Leigh and Zee 2006). Previous research has demonstrated that saccades are generated by high frequency bursts of activity in brainstem nuclei that project directly to the extraocular muscles (Fuchs et al. 1985; Scudder et al. 2002). Although the oculomotor system includes many cortical and subcortical areas within the brain (Hall and Moschovakis 2004), of particular relevance for this thesis are three areas: the superior colliculus (SC), the frontal eye fields (FEF) and the supplementary eye fields (SEF, see Fig. 1-1).

The SC is located on the dorsal surface of the midbrain and the intermediate and deep layers (iSC) are known to play a central role in the production of saccades. Stimulation of the iSC at a sufficient current produces saccadic eye movements that are virtually identical to volitionally generated saccades (Robinson 1972; Syka and Radil-Weiss 1971; Sparks and Hartwich-Young 1989). Researchers have recorded neural activity in the iSC during saccades and have found high-frequency bursts of activity associated with saccade onset (Wurtz and Goldberg 1972; Munoz and Wurtz 1995). The iSC also has been shown to project directly to the premotor nuclei involved in producing eye movements (Moschovakis et al. 1988; Scudder et al. 1996; Gandhi and Keller 1997).

Second, the FEF is found bilaterally in the anterior bank of the arcuate sulcus of the monkey brain and is also considered an important structure in generating visually

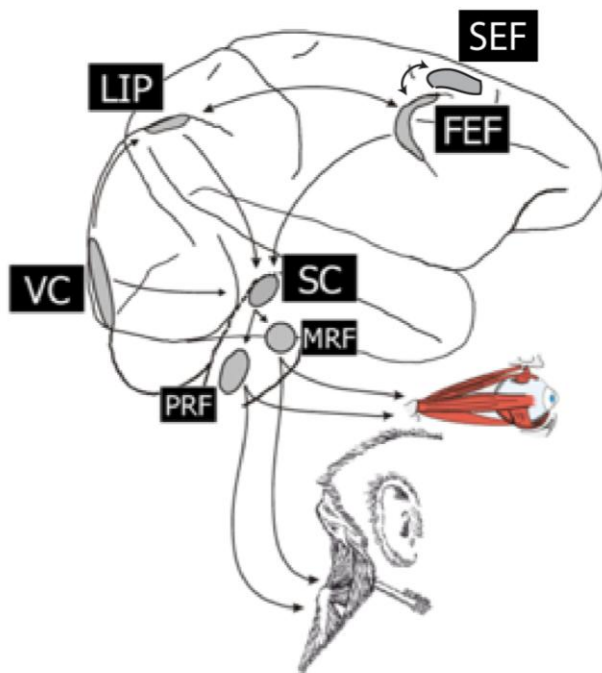

Figure 1-1: Simplified schematic diagram of oculomotor areas and pathways involved producing eye and head movements. SC: superior colliculus, FEF: frontal eye fields, SEF: supplementary eye fields, LIP: lateral intraparietal area, VC: visual cortex, MRF: mesencephalic reticular formation, PRF: pontine reticular formation.

guided saccades. The FEF has efferent and reciprocal connections with many cortical and subcortical neural areas involved in oculomotor control (Segraves 1992; Huerta et al. 1986; Stanton et al. 1988b; Stanton et al. 1993; Stanton et al. 1995). Similar to the SC, microstimulation of the FEF results in eye movements (Bruce et al. 1985) and recording studies have identified activity associated with saccade onset (Bruce and Goldberg 1985). These studies have shown that the evoked vector from a population of neurons is similar to the movement field of a neuron in the same area. Because the FEF and SC are integral to the production of saccadic eye movements, temporary or permanent inactivation of either structure results in some degradation of saccade performance [i.e. longer latencies, slower velocity and longer duration (Aizawa and Wurtz 1998; Hikosaka and Wurtz 1983; Quaia et al. 1998)]. Inactivation of both neural areas results in a severe impairment in the ability to produce eye movements (Schiller and Sandell 1983; Keating and Gooley 1988).

Finally, the Supplementary Eye Fields (SEF) is located in the dorsomedial section of the frontal cortex. The SEF has both direct and indirect projections to cortical areas and the brainstem nuclei involved in oculomotor control (Shook et al. 1990; Shook et al. 1991) suggesting a role for mediating saccades; however, this role differs from both the SC and FEF. Although stimulation of the SEF results in eye movements, inactivation of the SEF suggests it is not integral for the production of saccades (Schiller and Chou 1998). It is likely that the SEF is involved in the cognitive control of saccades, as it displays activity related to the context and consequences of saccades, visuomotor associations, error monitoring and reward (Stuphorn et al. 2000a; Chen and Wise 1995; Stuphorn and Schall 2006; Stuphorn et al. 2000b).

The SEF, FEF and SC have extensive reciprocal connections with each other in addition to direct connections with the pre-motor nuclei that themselves project to the extra-ocular muscles [see Fig. 1-2 (Hall and Moschovakis 2004)]. Consider the neurophysiological events in these areas that occur when a monkey is required to make a horizontal saccade to a visual stimulus presented in the right visual field. First, the appearance of a visual stimulus in the right visual field leads to phasic activation of visually responsive neurons in the SEF, FEF and SC on the contralateral (left) side of the brain. This activity occurs ~50-70 ms after stimulus presentation; although, onset of the visual response may vary slightly between the areas depending their position in the anatomical hierarchy (Schmolesky et al. 1998). A high-frequency burst of activity is produced some time after the visual burst in saccade related neurons in SEF, FEF and SC on the contralateral (left) side that is responsible for a rightward saccade. Signal flow leaving the cortex represents activity at nearly every stage of the sensori-motor transformation as well as post-saccadic, anticipatory and reward-related activity (Sommer and Wurtz 2001; Segraves and Goldberg 1987). This is a general overview of saccade production and due to space constraints other neural areas that influence saccade and gaze shift production such as the dorso-lateral prefrontal cortex (dlPFC), lateral intraparietal area (LIP) and the basal ganglia (BG) will not be discussed.

1.3 - Concepts of saccade production

The previous section discussed visual and motor related activity in a number of areas involved in saccade production. However, the terms ‘visual burst’ and ‘motor burst’ are

Figure 1-2. Simplified schematic drawing of the major relays from the supplementary eye fields (SEF) and frontal eye fields (FEF) to the eye or head. Black lines denote pathways between areas, with arrows representing the signal direction. Black lines with arrows pointing both ways show reciprocal connections between areas. The SEF is shown to target 5 areas either directly or indirectly. Direct connections are made to: i) FEF. ii) Superior colliculus (SC). iii) mesencephalic areas containing the rostral interstitial nucleus of the medial longitudinal fasciculus (riMLF), interstitial nucleus of Cajal (INC) and central mesencephalic reticular formation (cMRF). Indirect connections are made to: iv) a pontine area containing the nucleus reticularis pontis oralis (NRPo) and the nucleus reticularis pontis caudalis (NRPc). v) the pontomedullary nucleus reticularis gigantocellularis (NRGc). The mesencephalic, pontine and pontomedullary areas project onto the extraocular and/or neck muscles.

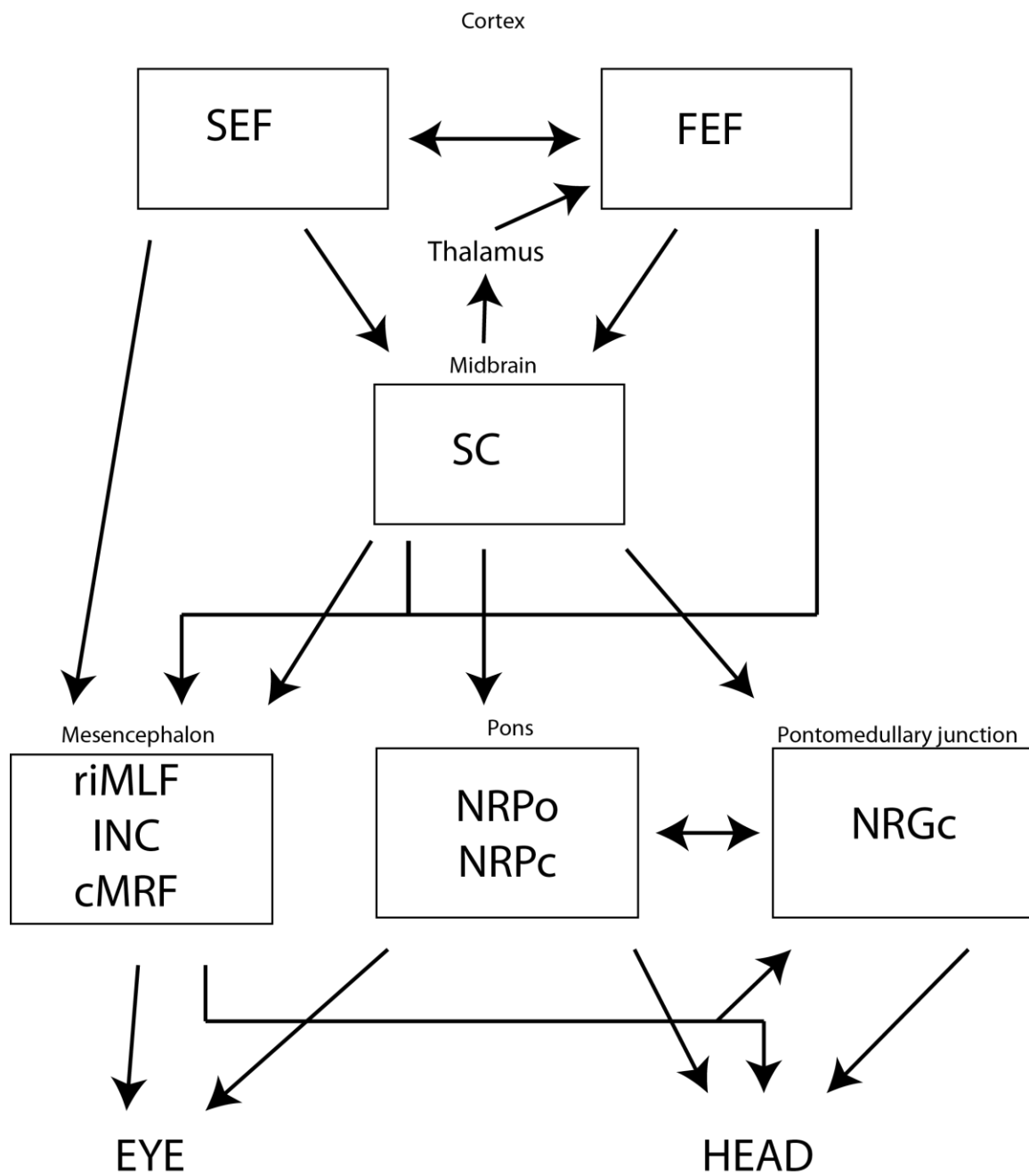

simply descriptions of a series of action potentials that are temporally aligned to sensory or motor events. The SC does appear to send visual signals downstream to nuclei responsible for generating a saccade (Rodgers et al. 2006). Since the visual and motor bursts refer to the activation of a neuron, why does the visual burst fail to elicit a saccade? A common model of saccade production can be utilized to answer this question: the accumulator model (see Fig 1-3A). To initiate a saccade, neural activity in an area (i.e. the FEF or SC) accumulates from a baseline until it exceeds a threshold. Neurophysiological studies have shown that variations in the rate of rise of FEF and SC activity after stimulus presentation can account for variations in reaction times (Paré and Hanes 2003; Hanes and Schall 1996) consistent with behavioral results (Hanes and Carpenter 1999; Carpenter and Williams 1995). Other studies have revealed that activity in the FEF or SC at the time of target appearance, referred to as baseline activity, can also affect reaction times (RTs, Everling et al. 1999; Dorris et al. 1997; Everling and Munoz 2000). If the visual response summates with neural activity, fast latency ‘express’ saccades can be produced, suggesting the visual burst can affect motor output under certain conditions (Sparks et al. 2000; Edelman and Keller 1996; Dorris et al. 1997).

The extraocular muscles are very responsive to input from the extraocular motoneurons. A single action potential from these extraocular motoneurons can alter eye position (Sparks et al. 2002). If the extraocular muscles are so sensitive, then the visual burst would consistently result in saccades; however, the visual burst usually does not trigger a saccade since it does not reach threshold. It is speculated that a group of neurons called omni-pause neurons (OPNs) act as a ‘gate’, potentially inhibiting visually-related activity from influencing extraocular moto-neurons (see Fig 1-3B). OPNs lie in

Figure 1-3. A) Schematic of the accumulator model demonstrating express and regular latency saccades. A fixation point (FP) is provided and immediately after FP removal a stimulus appears at an eccentric location. Threshold (horizontal dashed line) is placed arbitrarily. If the visual response sums with a sufficient amount of background activity, an express saccade will be generated. If the visual response sums with an insufficient amount of background activity, a regular latency saccade will be generated B) Schematic representation of ‘selective gating’, emphasizing that OPNs only inhibit the eye premotor circuitry. The superior colliculus projects to the eye and head premotor circuitry which subsequently projects to the eye and head as shown in Fig. 1-2. The omnipause neurons (OPNs) act as a ‘gate’ effectively preventing information from reaching the eye premotor circuitry. For information to pass through this gate and generate a saccade, the OPNs need to be inhibited.

A.

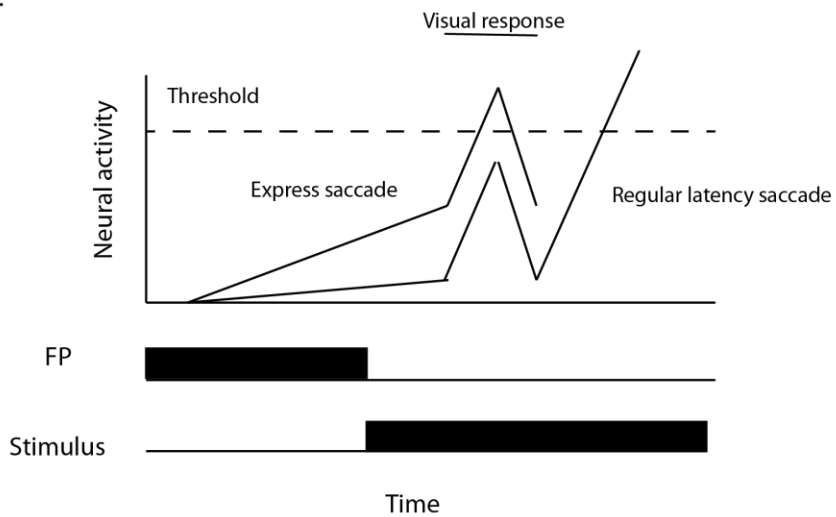

B.

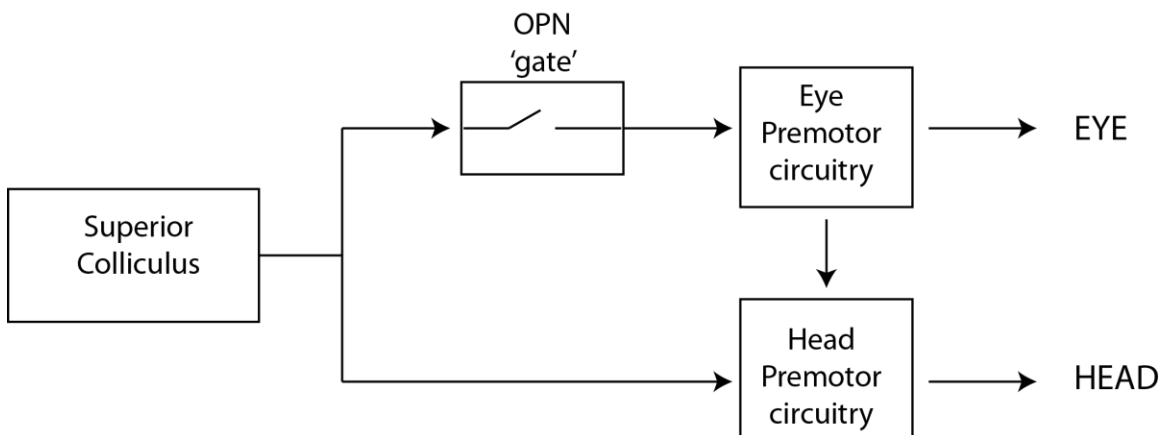

the nucleus raphe interpositus and a number of structures have connections with this region including the rostral pole of the SEF, FEF or SC (Shook et al. 1988; Buttner-Ennever et al. 1999; Gandhi and Keller 1997; Stanton et al. 1988a). OPNs discharge continuously during visual fixation and cease firing immediately before and during saccades in any direction. It has been suggested that inhibition of the OPNs is maintained during the saccade by short-lead burst neurons (Scudder et al. 2002). During visual fixation, OPNs tonically inhibit burst neurons that are responsible for generating saccades. OPNs have been speculated to relate to the threshold, via their potent inhibition; therefore, these neurons must be inhibited prior to the cascade of events involved in saccade onset.

1.4 - Eye-head gaze shifts

The saccade system, as described above, is ideal for examining current issues in motor control. Eye movements are easily measured via a number of different techniques, ranging from electro-oculography to more advanced video imaging systems. Different categories of eye movements are very distinct in nature and are controlled by three pairs of extraocular muscles. In contrast, the head is a much larger structure and has significant inertia. The neck musculature is also much more complex with > 24 neck muscles potentially influencing head movements. The development of neural activity preceding head movement cannot be inferred through head movement kinematics and issues regarding head movements are not as well understood as the eye movement system.

Saccades are ballistic in nature and movements are very stereotypical. The same cannot be said about the head. Unlike the eye, orienting head movements do not have a distinct repertoire of movements. The kinematics of head movement can vary, producing different velocity and acceleration profiles. A number of elastic, viscous and inertial forces can also affect head movements. Consider, for example, a volitional 15° head movement to the right. This can be carried out using a quick, high velocity orienting head movement, a slow, low velocity orienting head movement or a head movement using any desired velocity. Because the timing and metrics of saccades follow well known relationships, the underlying patterns of extraocular electromyographic (EMG) activity are relatively predictable. However, because of the large variation in timing and metrics of head movements and the apparent redundant musculature of the neck, we cannot be certain which muscles are moving the head. Our understanding of the neural control of head movement is, therefore, comparatively poor, certainly when compared to eye movements.

The SEF, FEF and SC have an important role in influencing saccades but also appear to be involved in controlling eye-head gaze shifts. Early experiments did not observe coordinated movement of the eye and head following SC stimulation (Stryker and Schiller 1975), and single unit recordings failed to identify activity related to head movements (Robinson and Jarvis 1974). In contrast to these results, stimulation experiments that sampled a larger portion of the SC evoked coordinated eye-head gaze shifts that are similar to volitionally generated gaze shifts (Freedman et al. 1996). Like volitional gaze shifts, when initial position of the eyes is deviated in the direction of the evoked gaze shifts the head contribution increases and latency of head movement onset

decreases. Head contribution to evoked gaze shifts also depends on the direction of the ensuing gaze shift, contributing less to vertical movements (Freedman and Sparks 1997b). Further, stimulation of the SC results in neck EMG responses that could vary in magnitude depending on the initial position of the eyes (Corneil et al. 2002). Recording studies reinforced the SC's role in eye-head gaze shifts. Activity was correlated with amplitude and direction of gaze regardless of the component movement of the eyes and head, suggesting that neural activity encoded with a single gaze command (Freedman and Sparks 1997a). Releasing the head also demonstrated a subset of neurons in the SC that were modulated in association with head movements even in the absence of gaze shifts (Walton et al. 2007). Thus certain neurons in the SC appear to encode a gaze command, while others are predominantly involved in generating head-only movements.

Microstimulation of the FEF has produced similar results to the SC. Stimulation of the FEF produces gaze shifts comprised of both eye and head movements that are similar to volitionally generated movements (Knight and Fuchs 2007; Tu and Keating 2000). Stimulation of the same FEF site resulted in constant amplitude gaze shifts that could have differing contributions of the eyes and head depending upon their respective starting positions (Tu and Keating 2000). Large gaze shifts with considerable head contribution were also evoked from the dorso-medial FEF. At some FEF sites and with varying initial position of the eyes, head-only movements could be evoked. Extracellular recording of a population of FEF cells has been identified that are exclusively related to head turning (Bizzi and Schiller 1970). The combined electrophysiological results suggest that the FEF, similar to the SC, encodes single gaze commands rather than separate commands for the eye and head. These signals are likely separated into the eye

and head components below the SC. The notion of a single gaze command was recently challenged following the stimulation of the FEF that resulted in head movements that did not contribute to the gaze shift (Chen 2006). However, recent evidence has shown widespread recruitment of neck muscle recruitment following FEF stimulation (Elsley et al. 2007). The implications of these findings would suggest that a gaze command is likely issued from the FEF.

Recent studies of head-unrestrained stimulation of the SEF resulted in primarily horizontal coordinated movements of the eyes and the head (Martinez-Trujillo et al. 2003). Additionally SEF stimulation produced similar amplitude-velocity relationships and head contributions as volitional gaze shifts (Martinez-Trujillo et al. 2003). These results suggest that the SEF issues a single gaze command that is decomposed into the eye and head components downstream. Head-alone movements were also elicited and occurred more frequently when the eyes were deviated to the side contralateral of stimulation (Chen and Walton 2005) suggesting that the SEF is involved in the control of head movements even in the absence of gaze shifts. Each SEF stimulation site specified a specific spatial location when plotted within its specific reference frame suggesting a variety of coding schemes that provides the SEF the ability to implement arbitrary reference frame transformations (Martinez-Trujillo et al. 2004). No neuronal recording studies have been conducted in the SEF with the head unrestrained.

As illustrated in Fig 1-3B, selective gating refers to the concept that OPNs act as a gate, preventing signals from reaching the extraocular muscles but do not gate signals related to head movements. A recent study has shown that stimulation of the OPNs during an eye-head gaze shift results in inhibiting the eye component but allows the head

to move along its trajectory (Gandhi and Sparks 2007). OPNs may be influenced by other gaze parameters such as eye counter-rotation (Phillips et al. 1999); however, it appears that the OPNs do not prevent signals from reaching the neck muscles.

Many issues regarding eye and head control still remain unsolved. There is an uncertainty regarding the timing of activity in premotor nuclei that generate head movements. Unlike the eye, there appears to be large variations in the timing and metrics of head movements. Also there is a redundant musculature of neck muscles with the possibility of multiple neck muscles being activated for the same movement. Therefore, we cannot assume that head movement kinematics is informative of the underlying neck muscle activity. In addition, the cortical and subcortical events that contribute to eye-head coordination are only beginning to be addressed. **The overall theme of this thesis will be to elucidate behavioral, muscular and neural processes involved in orienting head movements and also examine the contextual control of head orienting.** To accomplish this goal we will combine different behavioral tasks and cortical microstimulation with EMG recordings of neck muscles. As the kinematics of head movements is unreliable in addressing the neuromuscular commands, a direct measure of neck muscle activity is needed. EMGs provide high temporal resolution of neck muscle activity, on a ms by ms basis. Additionally, it provides information on which muscles are involved in particular movements and the timing and duration of neck muscle recruitment. To adequately and objectively assess neck muscle activity we utilize EMGs.

1.5 - Pro- and Anti-saccade task as a tool to assess contextual control

An important aspect of behavior is the ability to respond appropriately to varying contextual situations. In one situation, it may be appropriate to respond rapidly; however, in other situations, the suppression of a response would be ideal. The anti-saccade task is a well-utilized tool for studying the contextual control of movement [see Fig 1-4 (Hallett 1978)]. Unlike pro-saccades which require a subject to look towards a stimulus, anti-saccades require a subject to look to the diametrically opposite position of a stimulus. This task provides a stimulus-response incongruency that dissociates the stimulus location from the ensuing motor related response. Neuroimaging and electrophysiology studies have demonstrated many areas involved in the generation of correct anti-saccades including the SC, FEF, SEF, LIP and dIPFC (Schlag-Rey et al. 1997; Toth and Assad 2002; Zhang and Barash 2000; Everling et al. 1998; Everling and Munoz 2000; DeSouza et al. 2003; Everling et al. 1999; Funahashi et al. 1993; Zhang and Barash 2004; Gottlieb and Goldberg 1999; Olson and Gettner 2002; Amador et al. 2004; Sato and Schall 2003).

To correctly perform this task, one must first suppress a saccade towards the visual stimulus. When holding gaze on a fixation point (which also serves as an instruction on which task to perform) both the FEF and SC have well-defined populations of neurons that are related to fixation and saccades (Munoz and Schall 2003). These two

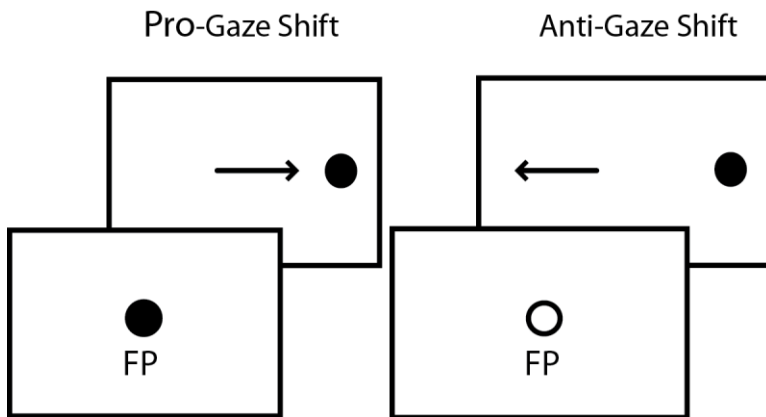

Figure 1-4. Schematic of the pro- and anti-saccade task. Based on the colour of the fixation point, a subject is required to either look towards a stimulus (pro-saccade) or away from a stimulus (anti-saccade).

neuronal populations work in a reciprocal fashion during the anti-saccade task (Everling and Munoz 2000; Everling et al. 1999). During anti-saccade trials, neurons associated with visual fixation in the FEF and SC are more active when compared to pro-saccades. Consider for example a stimulus that is presented to the right of the FP. On both pro- and anti-saccades, the onset of a visual stimulus results in a brief activation in the contralateral (left) neural areas. Following the visual burst, on pro-saccade trials, a high frequency burst of activity occurs in the left FEF and SC to generate a rightward pro-saccade. On anti-saccade trials, neurons in the left FEF and SC are inhibited while activity in the right FEF and SC can drive a movement to the left (away from the stimulus). At the level of individual neurons we can therefore see aspects of both ‘bottom- up’ visual related responses and ‘top down’ contextual control producing inhibition of a saccade towards the stimulus and generation of a volitional movement away from a stimulus. Interestingly, volitional activity in the right FEF and SC does not reach the same threshold required to generate a volitional pro-saccade (see *1.3 - Concepts saccade production*). For saccade neurons in the FEF and SC, the activity to produce a saccade is smaller compared to the magnitude of a response to a stimulus in its receptive field (Everling and Munoz 2000; Everling et al. 1999). This finding has led some to suggest the generation of correct anti-saccades requires additional input from other neural areas. Two likely candidates to provide this additional activity are the SEF and dIPFC (Schlag and Schlag-Rey 1987; Schlag and Schlag-Rey 1985). Both the SEF and dIPFC have visual and motor related responses and larger neuronal activity is observed during anti-saccades when compared to pro-saccades (Amador et al. 2004; Schlag-Rey et al. 1997). Similar to the SEF, the dIPFC also has connections with the FEF and SC

(Leichnetz et al. 1981; Goldman and Nauta 1976; Selemon and Goldman-Rakic 1988). It is possible that summation of activity from the FEF, SC, SEF and DLPFC allows a subject to generate a saccade away from a stimulus (Munoz and Everling 2004)

1.6 – Visual responses on neck muscles

Presentation of a visual stimulus leads to a short-latency, time-locked recruitment of the SEF, FEF and SC and this information is carried along the efferent SC pathway that targets both eye and head premotor centers (Rodgers et al. 2006). Because OPNs do not appear to inhibit head premotor structures, one can predict that the visual responses in the SC should produce a corresponding recruitment of neck muscles. Research has demonstrated that this response on neck muscles does occur and is time-locked to the presentation of the visual stimulus and is not dependent upon the timing of the ensuing movement (Corneil et al. 2004). In a more recent study, it was demonstrated that such time-locked visual responses of neck EMG activity are influenced by the allocation of visuo-spatial attention in a manner that resembles what is observed in the iSC (Corneil et al. 2008). One limitation of these two studies is that they have relied on behavioural tasks that encouraged reflexive orienting. Although much can be learned using this approach, it does not reveal the natural capabilities of a system able to produce flexible stimulus-response associations. Thus, it remains unclear whether the concept of selective gating of a head movement command will generalize to more complex tasks. The goal of chapter two is to examine neck muscle recruitment while monkeys perform pro- and anti-saccades. We are particularly interested in whether aspects of bottom-up and top-down

activity are reflected in neck muscle recruitment. Based on the hypothesis that OPNs do not inhibit oculomotor signals from accessing the premotor nuclei of the head, **we predict that aspects of bottom-up activity related to stimulus onset and top-down task dependent signals will occur on the neck muscles.** Because subjects are required to volitionally orient gaze away from a peripheral stimulus, this raises some important questions about signals arriving at the neck. Does the bottom-up visual response occur on anti-saccades? If so, is the visual burst dependent upon stimulus location or can the visual response vary depending on the contextual situation? In addition, will top-down task dependent signals during the anti-saccade task be reflected in neck muscle activity? By combining a task that requires the contextual control of movement with EMG recordings, we can potentially identify aspects of the signal content relayed along the tecto-reticulo-spinal or reticulo-spinal pathways.

1.7 - SEF and eye-head gaze shifts

As I will discuss shortly, the top-down task-dependent results we show in chapter two implicate structures in the frontal cortex, as indicated by imaging studies and data from clinical populations. Although areas such as the FEF, dlPFC and SEF would all be logical areas to investigate the task-dependent signals, the focal points of our research center around the SEF because of its confirmed involvement in eye-head gaze shifts (Chen and Walton 2005b; Martinez-Trujillo et al. 2003b) and its contextual modulation of neural activity (Schlag-Rey et al. 1997).

Although early work identified the SEF and its role in saccades, the systematic examination of the SEF was conducted many years after (Schlag and Schlag-Rey 1987).

Low-current stimulation of the SEF results in saccadic eye movements kinematically similar to volitional gaze shifts. The role for the SEF in eye movements is indicated by its anatomical connectivity with a number of cortical and subcortical oculomotor structures. Generally speaking, the SEF has connectivity patterns similar to the FEF, with which it is also interconnected. Microstimulation of the SEF can elicit saccades following lesions of the FEF or SC (Tehovnik et al. 1994). However, the function of direct brainstem projections from the SEF have been questioned as lesions of both the FEF and SC eliminate almost all saccadic eye movements.

Recently, research has shown that stimulation of the SEF can elicit coordinated movements of the eyes and head (Martinez-Trujillo et al. 2003b; Chen and Walton 2005b). Researchers have elicited kinematically normal eye-head gaze shifts suggesting that the SEF encodes a gaze command, providing further evidence that the independent control of the eye and head takes place downstream of the SC. However, the neuromuscular command issued by the SEF has yet to be systematically examined. The goal of project two is to examine the neuromuscular recruitment patterns following SEF stimulation. **We predict that SEF stimulation will produce neck EMG activity that relates to certain kinematics of the gaze shift such as direction and amplitude.** Based on the similar efferent connections with the brainstem, we could predict that low-current stimulation of the SEF will evoke neck muscle responses comparable to those evoked from the FEF. This would result in neck muscle activity that is stimulation-locked and would occur regardless of an accompanying gaze shift.

Although the SEF is involved in generating eye-head gaze shifts, its role is not simply as a motor structure. The SEF is also proposed to be involved in higher level,

cognitive capabilities such as, but not limited to, signalling the context and consequences of saccades. Neural recording studies during a countermanding task (where subjects attempt to cancel a planned movement) has demonstrated neuronal activity related to error-detection, reward, task difficulty and the degree of conflict between competing plans (Schall et al. 2002; Stuphorn et al. 2000a). Once again, these studies have been conducted with the head-restrained, and therefore unable to comment of the SEF's role in the contextual control of eye-head gaze shifts. Although the SEF has been implicated in generating head-fixed anti-saccades, little is known about the SEF's role in the contextual control of eye-head gaze shifts. To address this question, we will examine the influence of microstimulation on the SEF during anti-gaze shifts while monitoring neck EMG responses. **We predict that the SEF exerts contextual control over orienting head movements and that applying short duration stimulation in the SEF will result in greater modulation of neck muscle activity during anti-saccades.** This project is of importance as it is the first to address the potential role of the SEF in the contextual control of eye-head gaze shifts.

1.8 - Conclusion

This dissertation involves an experimental design using the rhesus macaque (*Macaca mulatta*) monkey to elucidate mechanisms of eye-head control. Specifically, I will focus on three objectives. First, to determine if top-down and bottom-up activity is present on the neck muscles during relatively complex tasks. Second, to examine the basic cephalomotor command issued from the SEF. Third, to identify if the SEFs are a potential source of top-down activity present on neck muscles. Chapters 2-4 will attempt

to address each objective respectively and have either been published or are in preparation to be published. This dissertation has been written in manuscript form and therefore each chapter is a distinct and novel project. The EMG results from chapter two raised questions regarding the origin of contextual signals which chapter four addressed. Chapter three provided the basic EMG responses that were necessary before initiating chapter four. Finally, chapter five will interpret the results and summarize the implications and limitations from the previous three chapters.

Reference List

- Aizawa H, Wurtz RH (1998) Reversible inactivation of monkey superior colliculus. I. Curvature of saccadic trajectory. *J Neurophysiol* 79:2082-2096
- Amador N, Schlag-Rey M, Schlag J (2004) Primate antisaccade. II. Supplementary eye field neuronal activity predicts correct performance. *J Neurophysiol* 91:1672-1689
- Bizzi E, Schiller PH (1970) Single unit activity in the frontal eye fields of unanesthetized monkeys during eye and head movement. *Exp Brain Res* 10:150-158
- Bruce CJ, Goldberg ME (1985) Primate frontal eye fields. I. Single neurons discharging before saccades. *J Neurophysiol* 53:603-635
- Bruce CJ, Goldberg ME, Bushnell MC, Stanton GB (1985) Primate frontal eye fields. II. Physiological and anatomical correlates of electrically evoked eye movements. *J Neurophysiol* 54:714-734
- Buttner-Ennever JA, Horn AK, Henn V, Cohen B (1999) Projections from the superior colliculus motor map to omnipause neurons in monkey. *J Comp Neurol* 413:55-67
- Carpenter RH, Williams ML (1995) Neural computation of log likelihood in control of saccadic eye movements. *Nature* 377:59-62
- Carpenter RHS (1991) *Visual origins of ocular motility*. MacMillan Press, London

- Chen LL (2006) Head movements evoked by electrical stimulation in the frontal eye field of the monkey: evidence for independent eye and head control. *J Neurophysiol* 95:3528-3542
- Chen LL, Walton MM (2005) Head movement evoked by electrical stimulation in the supplementary eye field of the rhesus monkey. *J Neurophysiol* 94:4502-4519
- Chen LL, Wise SP (1995) Neuronal activity in the supplementary eye field during acquisition of conditional oculomotor associations. *J Neurophysiol* 73:1101-1121
- Corneil BD, Munoz DP, Chapman BB, Admans T, Cushing SL (2008) Neuromuscular consequences of reflexive covert orienting. *Nat Neurosci* 11:13-15
- Corneil BD, Olivier E, Munoz DP (2002) Neck muscle responses to stimulation of monkey superior colliculus. I. Topography and manipulation of stimulation parameters. *J Neurophysiol* 88:1980-1999
- Corneil BD, Olivier E, Munoz DP (2004) Visual responses on neck muscles reveal selective gating that prevents express saccades. *Neuron* 42:831-841
- DeSouza JF, Menon RS, Everling S (2003) Preparatory set associated with pro-saccades and anti-saccades in humans investigated with event-related FMRI. *J Neurophysiol* 89:1016-1023
- Dorris MC, Paré M, Munoz DP (1997) Neuronal activity in monkey superior colliculus related to the initiation of saccadic eye movements. *J Neurosci* 17:8566-8579

- Edelman JA, Keller EL (1996) Activity of visuomotor burst neurons in the superior colliculus accompanying express saccades. *J Neurophysiol* 76:908-926
- Elsley JK, Nagy B, Cushing SL, Corneil BD (2007) Widespread presaccadic recruitment of neck muscles by stimulation of the primate frontal eye fields. *J Neurophysiol* 98:1333-1354
- Everling S, Dorris MC, Klein RM, Munoz DP (1999) Role of primate superior colliculus in preparation and execution of anti-saccades and pro-saccades. *J Neurosci* 19:2740-2754
- Everling S, Dorris MC, Munoz DP (1998) Reflex suppression in the anti-saccade task is dependent on prestimulus neural processes. *J Neurophysiol* 80:1584-1589
- Everling S, Munoz DP (2000) Neuronal correlates for preparatory set associated with pro-saccades and anti-saccades in the primate frontal eye field. *J Neurosci* 20:387-400
- Freedman EG, Sparks DL (1997a) Activity of cells in the deeper layers of the superior colliculus of the rhesus monkey: evidence for a gaze displacement command. *J Neurophysiol* 78:1669-1690
- Freedman EG, Sparks DL (1997b) Eye-head coordination during head-unrestrained gaze shifts in rhesus monkeys. *J Neurophysiol* 77:2328-2348

- Freedman EG, Stanford TR, Sparks DL (1996) Combined eye-head gaze shifts produced by electrical stimulation of the superior colliculus in rhesus monkeys. *J Neurophysiol* 76:927-952
- Fuchs AF, Kaneko CR, Scudder CA (1985) Brainstem control of saccadic eye movements. *Annu Rev Neurosci* 8:307-337
- Funahashi S, Chafee MV, Goldman-Rakic PS (1993) Prefrontal neuronal activity in rhesus monkeys performing a delayed anti-saccade task. *Nature* 365:753-756
- Gandhi NJ, Keller EL (1997) Spatial distribution and discharge characteristics of superior colliculus neurons antidromically activated from the omnipause region in monkey. *J Neurophysiol* 78:2221-2225
- Gandhi NJ, Sparks DL (2007) Dissociation of eye and head components of gaze shifts by stimulation of the omnipause neuron region. *J Neurophysiol* 98:360-373
- Goldman PS, Nauta WJ (1976) Autoradiographic demonstration of a projection from prefrontal association cortex to the superior colliculus in the rhesus monkey. *Brain Res* 116:145-149
- Gottlieb J, Goldberg ME (1999) Activity of neurons in the lateral intraparietal area of the monkey during an antisaccade task. *Nat Neurosci* 2:906-912
- Guitton D, Volle M (1987) Gaze control in humans: eye-head coordination during orienting movements to targets within and beyond the oculomotor range. *J Neurophysiol* 58:427-459

- Hall WC, Moschovakis A (2004) The Superior Colliculus: New approaches for studying sensorimotor integration. CRC Press, Boca Raton, FL
- Hallett PE (1978) Primary and secondary saccades to goals defined by instructions. *Vision Res* 18:1279-1296
- Hanes DP, Carpenter RH (1999) Countermanding saccades in humans. *Vision Res* 39:2777-2791
- Hanes DP, Schall JD (1996) Neural control of voluntary movement initiation. *Science* 274:427-430
- Hikosaka O, Wurtz RH (1983) Effects on eye movements of a GABA agonist and antagonist injected into monkey superior colliculus. *Brain Res* 272:368-372
- Huerta MF, Krubitzer LA, Kaas JH (1986) Frontal eye field as defined by intracortical microstimulation in squirrel monkeys, owl monkeys, and macaque monkeys: I. Subcortical connections. *J Comp Neurol* 253:415-439
- Keating EG, Gooley SG (1988) Saccadic disorders caused by cooling the superior colliculus or the frontal eye field, or from combined lesions of both structures. *Brain Res* 438:247-255
- Knight TA, Fuchs AF (2007) Contribution of the frontal eye field to gaze shifts in the head-unrestrained monkey: effects of microstimulation. *J Neurophysiol* 97:618-634

- Leichnetz GR, Spencer RF, Hardy SG, Astruc J (1981) The prefrontal corticotectal projection in the monkey; an anterograde and retrograde horseradish peroxidase study. *Neuroscience* 6:1023-1041
- Leigh RJ, Zee DS (2006) *The neurology of eye movements*. Oxford University Press,
- Martinez-Trujillo JC, Medendorp WP, Wang H, Crawford JD (2004) Frames of reference for eye-head gaze commands in primate supplementary eye fields. *Neuron* 44:1057-1066
- Martinez-Trujillo JC, Wang H, Crawford JD (2003a) Electrical stimulation of the supplementary eye fields in the head-free macaque evokes kinematically normal gaze shifts. *J Neurophysiol* 89:2961-2974
- Martinez-Trujillo JC, Wang H, Crawford JD (2003b) Electrical stimulation of the supplementary eye fields in the head-free macaque evokes kinematically normal gaze shifts. *J Neurophysiol* 89:2961-2974
- Moschovakis AK, Karabelas AB, Highstein SM (1988) Structure-function relationships in the primate superior colliculus. II. Morphological identity of presaccadic neurons. *J Neurophysiol* 60:263-302
- Munoz DP, Everling S (2004) Look away: the anti-saccade task and the voluntary control of eye movement. *Nat Rev Neurosci* 5:218-228

- Munoz DP, Schall JD (2003) In: Hall WC, Moschovakis A (eds) *The Superior Colliculus: New approaches for studying sensorimotor integrations*. CRC, Boca Raton, Florida, pp 55-82
- Munoz DP, Wurtz RH (1995) Saccade-related activity in monkey superior colliculus. I. Characteristics of burst and buildup cells. *J Neurophysiol* 73:2313-2333
- Olson CR, Gettner SN (2002) Neuronal activity related to rule and conflict in macaque supplementary eye field. *Physiol Behav* 77:663-670
- Paré M, Hanes DP (2003) Controlled movement processing: superior colliculus activity associated with countermanded saccades. *J Neurosci* 23:6480-6489
- Phillips JO, Ling L, Fuchs AF (1999) Action of the brain stem saccade generator during horizontal gaze shifts. I. Discharge patterns of omnidirectional pause neurons. *J Neurophysiol* 81:1284-1295
- Quaia C, Aizawa H, Optican LM, Wurtz RH (1998) Reversible inactivation of monkey superior colliculus. II. Maps of saccadic deficits. *J Neurophysiol* 79:2097-2110
- Robinson DA (1972) Eye movements evoked by collicular stimulation in the alert monkey. *Vision Res* 12:1795-1808
- Robinson DL, Jarvis CD (1974) Superior colliculus neurons studied during head and eye movements of the behaving monkey. *J Neurophysiol* 37:533-540
- Rodgers CK, Munoz DP, Scott SH, Pare M (2006) Discharge properties of monkey tectoreticular neurons. *J Neurophysiol* 95:3502-3511

- Sato TR, Schall JD (2003) Effects of stimulus-response compatibility on neural selection in frontal eye field. *Neuron* 38:637-648
- Schall JD, Stuphorn V, Brown JW (2002) Monitoring and control of action by the frontal lobes. *Neuron* 36:309-322
- Schiller PH, Chou IH (1998) The effects of frontal eye field and dorsomedial frontal cortex lesions on visually guided eye movements. *Nat Neurosci* 1:248-253
- Schiller PH, Sandell JH (1983) Interactions between visually and electrically elicited saccades before and after superior colliculus and frontal eye field ablations in the rhesus monkey. *Exp Brain Res* 49:381-392
- Schlag J, Schlag-Rey M (1985) Unit activity related to spontaneous saccades in frontal dorsomedial cortex of monkey. *Exp Brain Res* 58:208-211
- Schlag J, Schlag-Rey M (1987) Evidence for a supplementary eye field. *J Neurophysiol* 57:179-200
- Schlag-Rey M, Amador N, Sanchez H, Schlag J (1997) Antisaccade performance predicted by neuronal activity in the supplementary eye field. *Nature* 390:398-401
- Schmolesky MT, Wang Y, Hanes DP, Thompson KG, Leutgeb S, Schall JD, Leventhal AG (1998) Signal timing across the macaque visual system. *J Neurophysiol* 79:3272-3278
- Scudder CA, Kaneko CS, Fuchs AF (2002) The brainstem burst generator for saccadic eye movements: a modern synthesis. *Exp Brain Res* 142:439-462

- Scudder CA, Moschovakis AK, Karabelas AB, Highstein SM (1996) Anatomy and physiology of saccadic long-lead burst neurons recorded in the alert squirrel monkey. I. Descending projections from the mesencephalon. *J Neurophysiol* 76:332-352
- Segraves MA (1992) Activity of monkey frontal eye field neurons projecting to oculomotor regions of the pons. *J Neurophysiol* 68:1967-1985
- Segraves MA, Goldberg ME (1987) Functional properties of corticotectal neurons in the monkey's frontal eye field. *J Neurophysiol* 58:1387-1419
- Selemon LD, Goldman-Rakic PS (1988) Common cortical and subcortical targets of the dorsolateral prefrontal and posterior parietal cortices in the rhesus monkey: evidence for a distributed neural network subserving spatially guided behavior. *J Neurosci* 8:4049-4068
- Shook BL, Schlag-Rey M, Schlag J (1988) Direct projection from the supplementary eye field to the nucleus raphe interpositus. *Exp Brain Res* 73:215-218
- Shook BL, Schlag-Rey M, Schlag J (1990) Primate supplementary eye field: I. Comparative aspects of mesencephalic and pontine connections. *J Comp Neurol* 301:618-642
- Shook BL, Schlag-Rey M, Schlag J (1991) Primate supplementary eye field: II. Comparative aspects of connections with the thalamus, corpus striatum, and related forebrain nuclei. *J Comp Neurol* 307(4):562-583

- Sommer MA, Wurtz RH (2001) Frontal eye field sends delay activity related to movement, memory, and vision to the superior colliculus. *J Neurophysiol* 85:1673-1685
- Sparks D, Rohrer WH, Zhang Y (2000) The role of the superior colliculus in saccade initiation: a study of express saccades and the gap effect. *Vision Res* 40:2763-2777
- Sparks DL, Barton EJ, Gandhi NJ, Nelson J (2002) Studies of the role of the paramedian pontine reticular formation in the control of head-restrained and head-unrestrained gaze shifts. *Ann N Y Acad Sci* 956:85-98
- Sparks DL, Hartwich-Young R (1989) The deep layers of the superior colliculus. *Rev Oculomot Res* 3:213-255
- Stanton GB, Bruce CJ, Goldberg ME (1993) Topography of projections to the frontal lobe from the macaque frontal eye fields. *J Comp Neurol* 330:286-301
- Stanton GB, Bruce CJ, Goldberg ME (1995) Topography of projections to posterior cortical areas from the macaque frontal eye fields. *J Comp Neurol* 353:291-305
- Stanton GB, Goldberg ME, Bruce CJ (1988a) Frontal eye field efferents in the macaque monkey: I. Subcortical pathways and topography of striatal and thalamic terminal fields. *J Comp Neurol* 271:473-492

- Stanton GB, Goldberg ME, Bruce CJ (1988b) Frontal eye field efferents in the macaque monkey: II. Topography of terminal fields in midbrain and pons. *J Comp Neurol* 271:493-506
- Stryker MP, Schiller PH (1975) Eye and head movements evoked by electrical stimulation of monkey superior colliculus. *Exp Brain Res* 23:103-112
- Stuphorn V, Schall JD (2006) Executive control of countermanding saccades by the supplementary eye field. *Nat Neurosci* 9:925-931
- Stuphorn V, Taylor TL, Schall JD (2000) Performance monitoring by the supplementary eye field. *Nature* 408:857-860
- Syka J, Radil-Weiss T (1971) Electrical stimulation of the tectum in freely moving cats. *Brain Res* 28:567-572
- Tehovnik EJ, Lee K, Schiller PH (1994) Stimulation-evoked saccades from the dorsomedial frontal cortex of the rhesus monkey following lesions of the frontal eye fields and superior colliculus. *Exp Brain Res* 98:179-190
- Toth LJ, Assad JA (2002) Dynamic coding of behaviourally relevant stimuli in parietal cortex. *Nature* 415:165-168
- Tu TA, Keating EG (2000) Electrical stimulation of the frontal eye field in a monkey produces combined eye and head movements. *J Neurophysiol* 84:1103-1106
- Walton MM, Bechara B, Gandhi NJ (2007) The role of the primate superior colliculus in the control of head movements. *J Neurophysiol* 98(4): 2022-2037

Wurtz RH, Goldberg ME (1972) Activity of superior colliculus in behaving monkey. 3. Cells discharging before eye movements. *J Neurophysiol* 35:575-586

Zhang M, Barash S (2000) Neuronal switching of sensorimotor transformations for antisaccades. *Nature* 408:971-975

Zhang M, Barash S (2004) Persistent LIP activity in memory antisaccades: working memory for a sensorimotor transformation. *J Neurophysiol* 91:1424-1441

Chapter 2

Neuromuscular recruitment related to stimulus presentation and task instruction during the anti-saccade task

Brendan B. Chapman¹ and Brian D. Corneil¹⁻³

Graduate Program in Neuroscience¹
Departments of Physiology & Pharmacology² and Psychology³,
University of Western Ontario,
London, Ontario, Canada N6A 5C1

European Journal of Neuroscience, 33(2): 349-360, 2011

ABSTRACT

The contextual control of movement requires the transformation of sensory information into appropriate actions, guided by task-appropriate rules. Previous conceptualizations of the sensorimotor transformations underlying anti-saccades (look away from a stimulus) have suggested that stimulus location is first registered and subsequently transformed into its mirror location before being relayed to the motor periphery. Here, by recording neck muscle activity in monkeys performing anti-saccades, we demonstrate that stimulus presentation induces a transient recruitment of the neck muscle synergy used to turn the head in the wrong direction, even though subjects subsequently looked away from the stimulus correctly. Such stimulus-driven aspects of recruitment developed essentially at reflexive latencies ($\sim 60\text{--}70$ ms after stimulus presentation), and persisted at modest eccentricities regardless of head-restraint. Prior to stimulus presentation, neck muscle activity also reflected whether the animals were preparing for an anti-saccade or a pro-saccade (look toward a stimulus). Neck muscle activity prior to erroneous anti-saccades also resembled that observed prior to pro-saccades. These results emphasize a parallel nature to the sensorimotor transformations underlying the anti-saccade task, suggesting that the top-down and bottom-up processes engaged in this task influence the motor periphery. The bottom-up aspects of neck muscle recruitment also fit within the context of recent results from the limb-movement literature, showing that stimulus-driven activation of muscle synergies may be a generalizing strategy in inertial-laden systems.

2.1 - INTRODUCTION

The anti-saccade task, which requires subjects to look to the diametrically opposite location of a peripheral visual stimulus, has become an important paradigm for studying the contextual control of movement (Hallett, 1978; Munoz & Everling, 2004). This task involves a form of stimulus–response incompatibility, as subjects must suppress the tendency to look to the peripheral stimulus and transform stimulus location into a motor command for a saccade in the opposite direction. A number of clinical populations are deficient in this task (Guitton et al., 1985; Gaymard et al., 1998; Vidailhet et al., 1999; Crawford et al., 2002), consistent with the importance of the frontal lobes in contextual control of movement. The availability of a non-human primate model of this task (Amador et al., 1998; Bell et al., 2000) has enabled investigations of underlying neural processing throughout the neuraxis (Schlag-Rey et al., 1997; Everling et al., 1999; Everling & Munoz, 2000; Olson & Gettner, 2002; Sato & Schall, 2003; Johnston & Everling, 2006). Such investigations have revealed how ‘bottom-up’ signals related to stimulus presentation are integrated with ‘top-down’ signals conveying task instruction into an appropriate motor command.

Presentation of a visual stimulus initiates a cascade of short-latency visual responses in striate and extrastriate cortices, and in numerous oculomotor areas in parietal cortex, frontal cortex, and the brainstem (Wurtz et al., 1980; Bruce & Goldberg, 1985; Colby et al., 1996; Schmolesky et al., 1998; Bisley et al., 2004; Pouget et al., 2005; Bell et al., 2006; Kirchner et al., 2009). This visual-grasp reflex (Hess et al., 1946) culminates in consistently short-latency, time-locked recruitment of neck (Corneil et al., 2004, 2008) and limb muscles (Pruszynski et al., 2010). It is thought that these visual responses on

neck or limb muscles may be due to selective gating of descending commands from the superior colliculus, permitting recruitment of head or limb motor circuits without necessitating gaze shifts.

These results suggest that stimulus presentation induces a reflexive series of neural events culminating in motor recruitment. The goal of this manuscript is to examine neck muscle activity in an anti-saccade task, with one objective being to answer whether stimulus presentation leads to a reflexive visual response on the neck muscles that turn the head in the wrong direction. Such a finding would suggest that the bottom-up processes engaged by stimulus presentation induce an erroneous manifestation in the motor periphery, even when gaze is ultimately moved in the correct direction. A second objective investigates whether neck muscle activity displays any dependency with top-down task instruction prior to stimulus onset and, if so, whether such activity is predictive of ensuing task performance. Addressing these objectives will provide additional insights into the oculomotor circuits mediating contextual control in a task widely used as an exemplar for stimulus–response incompatibility.

Sections of this manuscript have previously been presented in abstract form (Chapman & Corneil, 2007).

2.2 - METHODS

2.2.1 - Subjects and surgical procedures

Two male rhesus macaque monkeys (*Macaca mulatta*, monkeys *je* and *gr*) weighing approximately 6 and 5.5 kg, respectively, performed this experiment. Each

animal underwent two surgeries as described elsewhere (Elsley et al., 2007). In the first surgery, a head post and scleral search coil were implanted and anchored into an acrylic implant to permit head-restraint and the monitoring of eye position, respectively (Judge et al., 1980). In the second surgery, bipolar hook electrodes were implanted bilaterally in five neck muscles that are involved in orienting the head both horizontally and vertically. We focus on obliquus capitis inferior and rectus capitis posterior major (OCI and RCM; Fig. 2-1 A), which are small suboccipital muscles that form the core of the ipsilateral head-turning synergy in the monkey (Lestienne et al., 1995; Corneil et al., 2001). All experiments were conducted in accordance with the Canadian Council on Animal Care policy as well as protocol issued by the Animal Use Subcommittee of the University of Western Ontario Council on Animal Care.

2.2.2 - Training and behavioral paradigm

Prior to electromyographic (EMG) recordings, monkeys were placed in a customized primate chair (Crist Instruments, Hagerstown, MD, USA) designed to either completely restrain the head from any movement or allow complete motility of the head. Each monkey wore a customized jacket (Lomir Biomedical, QC) that could be attached to the primate chair and restricted trunk rotation to a maximum of 10° in any direction. The monkeys were then placed into a dark, sound-attenuated room, and placed within the center of a 3-ft³ coil system (CNC Engineering, Seattle, WA, USA) 24 inches in front of an array of horizontal tri-colored (red, green or orange) equiluminant LEDs. Both monkeys learned the anti-saccade task (Fig. 1 B) with the head restrained. To learn the

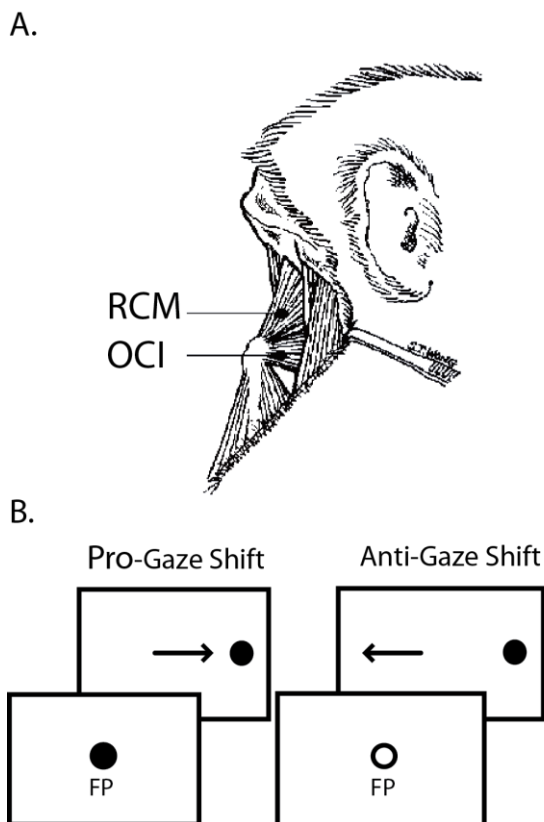

Figure 2-1. (A) Line-drawing of the deeper muscles of the dorsal neck, highlighting some of the suboccipital muscles involved in ipsilateral head turns. Obliquus capitis inferior (OCI) spans from the middle of the C2 vertebrae to the outside of the C1 vertebrae. Rectus capitis posterior major (RCM) spans from the middle of the C2 vertebrae to the skull. (B) Schematic of the anti-saccade task. The color of a central fixation point (FP) signified the type of trial (red = pro-saccade; green = anti-saccade).

anti-saccade task, a red and green stimulus was presented on opposite sides of a green central fixation point (FP), and monkeys learned to look to the stimulus that matched the color of the FP. The intensity of the peripheral green stimulus was gradually reduced on green FP trials until it was completely extinguished so that monkeys were making anti-saccades by looking away from the red stimulus.

Once the monkeys were proficient at the task with the head restrained, we released the head to collect head-unrestrained anti-saccade data. All head-unrestrained trials began with the extinguishing of a diffuse background white light that was presented to prevent dark adaptation. A red or green FP was presented directly in front of the monkey. The monkeys were required to look at the FP within 1000 ms and hold gaze within a computer-controlled window (radius = 5°) for a period of 450 (monkey *je*) or 600 (monkey *gr*) ms. A red or green FP instructed the monkeys to generate a pro-saccade or anti-saccade, respectively, in response to stimulus onset. The stimulus was presented randomly to the left or the right of the FP, and the monkeys had to direct gaze either toward or away from this stimulus within 1000 ms. The monkeys had to maintain stable fixation within a window around the goal location for 600 ms (on anti-saccade trial, a stimulus was presented at the goal location halfway through this interval to reinforce the task). A 1000-ms inter-trial interval was presented between trials. A block consisted of ~200 trials of intermixed pro- and anti-saccade trials presented with an equal probability. Within a block, peripheral stimuli were placed at a fixed horizontal eccentricity; across blocks, stimulus location was varied amongst 15, 20, 27, 35, 45 and 60° . We collected a total of ~800 trials (400 pro-saccade and 400 anti-saccade trials) at each eccentricity. A customized LABVIEW program controlled the experiment in real-time at a rate of 1 kHz

through a PXI box (National Instruments) and implemented sub-blocks of 20 trials (five pseudo-randomized trials of each unique trial and direction combination) to ensure that the monkeys were making pro- and anti-saccades during each block. A liquid reward was administered at the end of each correct trial through a sipper tube that was attached to the head post. The sipper tube did not interfere with either head movements or viewing of the stimuli. We also collected data from monkey *je* with the head restrained, with stimulus eccentricity varying amongst 10, 15, 20, 27 and 35° across blocks.

2.2.3 - Data collection and processing

Head rotations were measured via a second coil secured to the head post in the frontal plane. Horizontal gaze (eye-in-space) and head movements were filtered, amplified and digitized at a rate of 10 kHz onto a MAP box (Plexon, Dallas, TX, USA). Off-line, coil signals were down-sampled by a factor of 10–1 kHz. Monkeys were monitored throughout the experiment by investigators via infrared cameras positioned outside the monkey's line of sight. The protocol for processing EMG signals has been described elsewhere (Elsley et al., 2007); briefly, the processing of the EMG signals commenced at a headstage plugged directly onto the EMG connector embedded within the acrylic implant. This headstage performed differential amplification of the EMG signals (20x gain) and filtering (bandwidth, 20–17 kHz). A flexible ribbon cable linked the headstage to the Plexon preamplifier, which contained a signal processing board customized for EMG recordings (50x gain; bandwidth, 100–4 kHz). EMG signals were notch filtered to remove 60-Hz noise, rectified and integrated into 1-ms bins, using a rationale described previously (Bak & Loeb, 1979). These steps (particularly the

rectification of the EMG signal) attenuated the digitized peak-to-peak voltages by a factor of ~ 3 .

Offline analysis was conducted via customized MATLAB (The Mathworks, Nantick, MA, USA) programs. We designed an interface permitting an analyst to inspect all trials and discard trials if, for example, there were aberrant patterns of gaze movements or excessive background EMG activity across the recorded muscles (e.g. if the animal was shifting position). This program also automatically detected the beginning and end of gaze shifts and head movements using velocity crossing thresholds of 30 or 10 deg/s, respectively. Anticipatory movements (< 60 ms from stimulus presentation) and movements that showed a lack of attention (> 600 ms from stimulus presentation) were excluded from analysis ($< 5\%$ of movements were removed with these criteria). Customized MATLAB programs extracted aspects of behavioral performance and analyzed muscle recruitment. The rationale and details of these methodologies are provided below.

2.2.4 - Data analysis

Customized MATLAB programs extracted aspects of behavioral performance and analyzed muscle recruitment. A key part of our analysis is to examine when the recruitment of a given muscle differed depending on whether a stimulus was presented to the left or right. Accordingly, we adopted a time-series receiver operating characteristic (ROC) analysis, as described previously (Corneil et al., 2004). Briefly, for every time point spanning from 100 ms before stimulus presentation to 300 ms after, we calculated the area under the ROC curve. This metric is based on the comparative distribution of EMG activity from all trials at that time point, segregated by whether the stimulus

appeared ipsilateral or contralateral to the muscle under consideration. The metric expresses the probability that an ideal observer could correctly distinguish the side of stimulus presentation based solely on such EMG activity. A value of 0.5 indicates that the observer would perform at chance, whereas a value of 0.0 or 1.0 indicates perfect performance. We use such time-series ROC plots to define the ‘discrimination time’, which was defined as the time at which the ROC metric exceeded a value of 0.6 for five of eight consecutive points. The value of 0.6 was chosen as the threshold as this exceeds the 95% confidence interval determined by the distribution of ROC values in the 100 ms preceding stimulus presentation. In practice, modifications in either the threshold value or the number of points required to exceed this value had only a minor influence on discrimination time, as the ROC metric typically increased sharply around the time of the visual response on neck muscles.

2.3 - RESULTS

2.3.1 - Behavioral assessment of head-unrestrained anti-saccades

Both monkeys became very proficient at the anti-saccade task with performance > 75% at all eccentricities, but they displayed slightly different patterns of behavior (Table 1). Monkey *je* initiated gaze saccades and head movements ~40 ms earlier on pro- vs. anti-saccade trials, whereas monkey *gr* initiated movements at approximately equal reaction times (RTs) regardless of trial type. Although this result may seem surprising, monkey *gr* had substantially longer RTs than monkey *je* (paired *t*-test of mean RT for pro- and anti-saccades across eccentricity, $t_{11} = 5.51$, $P = 10^{-4}$), and others have reported

shorter RTs on anti-saccade trials in some monkeys (Amador et al., 1998; Johnston & Everling, 2006). In terms of peak velocity, both monkeys generated slower gaze saccades and head movements on anti-saccade trials for the larger stimulus eccentricities (e.g. $\geq 30^\circ$), consistent with the absence of a visual target at the goal location (Edelman et al., 2006). In general, these patterns resemble those described in previous reports of anti-saccade behavior in head-restrained monkeys (Amador et al., 1998; Bell et al., 2000) and head-unrestrained humans (Chapman & Corneil, 2008). Monkey *je* also performed the anti-saccade task with the head restrained, and generated anti-saccades at longer RTs and slower peak velocities compared with pro-saccades (Table 1).

We also analyzed the propensity for both monkeys to produce ‘head-only’ errors toward the stimulus on anti-saccade trials. Head-only errors, which are generally between 3 and 7° in amplitude and can reach peak velocities of over 50 deg/s, have been observed in a variety of paradigms featuring competitive environments or changing experimental contexts (Ron & Berthoz, 1991; Corneil & Munoz, 1999; Pélisson et al., 2001; Corneil & Elsley, 2005). Such sequences consist of an orienting head movement toward a stimulus and a compensatory vestibulo-ocular reflex movement of the eye-in-head to maintain gaze stability. Consistent with results in humans (Chapman & Corneil, 2008), both monkeys produced negligible numbers of head-only movements (Table 1). However, as we will show in a later section, both monkeys produced a pattern of very subtle stimulus-directed head movements that were well below our detection criteria.

2.3.2 - Neck muscle activity during head-unrestrained anti-saccades

We examined the recruitment of dorsal suboccipital muscles across trial type

Table 2-1: Reaction times, velocities and error rates for both monkeys in the head-unrestrained condition and for monkey je in the head-restrained condition across all eccentricities. Standard deviations are presented with both RTs and velocities. Bolded pairs (pro- vs. anti-) of measurements represent significant differences at $p < 0.05$.

Monkey	Reaction Time				Velocity				Anti-saccade Error rates	Head-Only Error Rates
	Pro-Gaze RT ms	Anti-Gaze RT ms	Pro-Head RT ms	Anti-Head RT ms	Pro-Gaze Vel. %/s	Anti-Gaze Vel. %/s	Pro-Head Vel. %/s	Anti-Head Vel %/s		
									%	%
Unrestrained										
G -60°	304 ± 52	289 ± 52	241 ± 44	238 ± 49	864 ± 137	814 ± 139	410 ± 112	353 ± 117	22	1.4
G -45°	318 ± 55	301 ± 52	255 ± 56	247 ± 41	760 ± 125	693 ± 141	242 ± 44	204 ± 56	20	1.1
G -35°	299 ± 39	293 ± 58	231 ± 31	228 ± 49	934 ± 135	879 ± 138	220 ± 33	194 ± 44	14	1.3
G -27°	291 ± 48	287 ± 47	238 ± 39	235 ± 44	875 ± 119	770 ± 161	134 ± 22	130 ± 20	9	0.7
G -20°	265 ± 42	261 ± 41	222 ± 36	215 ± 35	836 ± 81	746 ± 148	129 ± 21	130 ± 22	7	1.0
G -15°	238 ± 36	245 ± 44	203 ± 36	189 ± 34	836 ± 104	875 ± 186	127 ± 21	176 ± 55	12	1.8
J -60°	196 ± 53	232 ± 41	161 ± 33	186 ± 42	829 ± 107	775 ± 101	231 ± 27	217 ± 32	11	3.0
J -45°	206 ± 45	245 ± 65	183 ± 43	198 ± 55	853 ± 111	802 ± 101	195 ± 35	193 ± 40	16	3.0
J -35°	220 ± 41	254 ± 56	204 ± 37	210 ± 57	865 ± 88	780 ± 111	139 ± 22	145 ± 28	14	1.4
J -27°	198 ± 33	239 ± 62	189 ± 33	197 ± 60	770 ± 58	684 ± 97	113 ± 11	125 ± 19	10	1.6
J -20°	208 ± 43	248 ± 55	211 ± 42	209 ± 57	759 ± 55	684 ± 99	127 ± 31	114 ± 12	14	0.1
J -15°	186 ± 41	259 ± 58	165 ± 39	184 ± 44	575 ± 59	521 ± 99	127 ± 32	132 ± 21	10	0.9
Restrained										
J - 35°	236 ± 57	241 ± 42	N/A	N/A	730 ± 66	598 ± 145	N/A	N/A	19	N/A
J - 27°	217 ± 55	221 ± 46	N/A	N/A	746 ± 79	597 ± 174	N/A	N/A	15	N/A
J - 20°	210 ± 45	236 ± 41	N/A	N/A	671 ± 46	531 ± 140	N/A	N/A	20	N/A
J - 15°	195 ± 45	226 ± 38	N/A	N/A	586 ± 42	475 ± 99	N/A	N/A	14	N/A
J - 10°	203 ± 51	256 ± 54	N/A	N/A	422 ± 38	362 ± 72	N/A	N/A	17	N/A

(pro- vs. anti-saccade) and stimulus eccentricity. We first show representative data recorded from the right-OCI muscle while monkey *je* made head-unrestrained pro- and anti-saccades to stimuli appearing 35° left or right (Fig. 2-2). Here, data are aligned to stimulus onset, and segregated by trial type and the side of stimulus presentation (within each subplot, each row shows data from a different trial). Rightward stimulus presentation on pro-saccade trials elicited a transient increase in activity (~20 ms in duration) on the right-OCI muscle (i.e. stimulus ipsilateral to the muscle; Fig. 2-2 A; solid rectangle in right panel), whereas leftward stimulus presentation elicited a mirroring suppression of EMG activity (Fig. 2-2 A; dashed rectangle in left panel). Such lateralized recruitment began ~60–70 ms following stimulus onset, regardless of the ensuing RT, and was present on most if not all trials. Following this visual response, right-OCI displayed more prolonged changes in activity, increasing before rightward head movements and decreasing before leftward head movements. We observed a reciprocal profile of recruitment on left-OCI (data not shown in Fig. 2-2). Overall, the results from pro-saccade trials are consistent with our previous reports of visual responses on neck muscles (Corneil et al., 2004, 2008).

The anti-saccade task provides an opportunity to investigate such visual responses in conditions involving stimulus–response incompatibility. Stimulus presentation in the anti-saccade task elicited the same initial pattern of neck muscle recruitment as in the pro-saccade task (Fig. 2-2B for right-OCI). Here, rightward (ipsilateral) stimulus presentation elicited a brief burst of recruitment ~60–70 ms later (Fig. 2-2 B, solid rectangle in right panel), even though the ensuing gaze shift proceeded leftward. In contrast, a brief

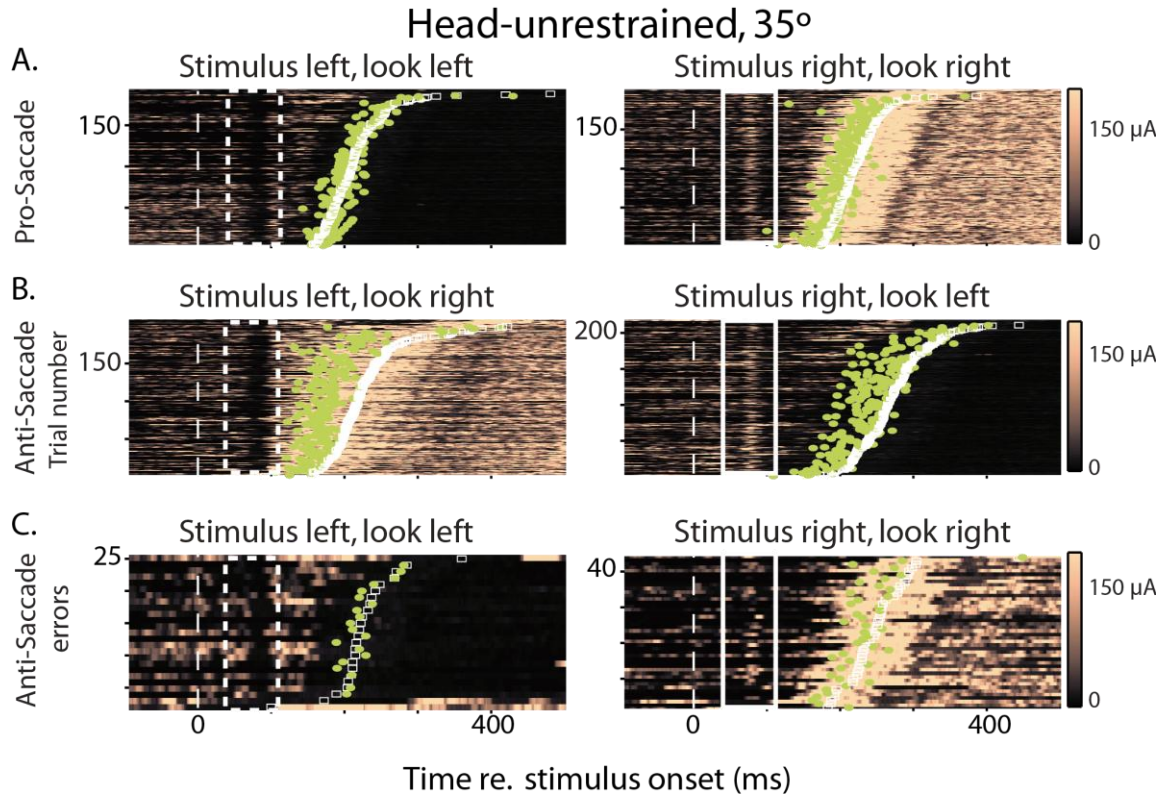

Figure 2-2. Representative example of neck muscle recruitment on pro- and anti-saccade trials, showing the activity of right-OCI from monkey *je* while head-unrestrained with stimuli placed at 35°. Each subplot displays EMG activity aligned on stimulus presentation (white dashed line), segregated by trial type [pro-saccades (A), correctly performed anti-saccades (B), incorrectly performed anti-saccades (C)]. Left or right columns show data for stimuli presented to the left or right, respectively. Solid or dashed white rectangles denote changes in muscle recruitment aligned to stimulus onset. White squares represent gaze RT while green circles represent head RT. Data have been sorted by increasing gaze RT.

band of suppression followed leftward (contralateral) stimulus presentation (Fig. 2-2 B, dashed rectangle in left panel). Thus, stimulus presentation in an anti-saccade task elicits a visual response on the ‘wrong’ neck muscles, relative to the goal of the task. Again, such recruitment was also present on most if not all trials. Shortly after this visual response, neck muscle activity resolved into a recruitment pattern consistent with movement direction; right-OCI activity decreased before leftward head motion, but increased before rightward head motion.

Figure 2-2 C presents the recruitment of right-OCI when the monkey *je* made anti-saccade errors by looking incorrectly towards the stimulus on anti-saccade trials. Once again, stimulus presentation was followed by time-locked lateralization of right-OCI activity, increasing or decreasing following rightward or leftward stimulus presentation, respectively. Following this visual response, right-OCI activity increased further for rightward head motion, and decreased for leftward head motion. Overall, the recruitment profile on anti-saccade errors resembled that observed on pro-saccade trials. We consistently observed visual responses on neck muscles ipsilateral to stimulus presentation in both pro- and anti-saccade trials in both animals. Moreover, we also observed visual responses on neck muscles on most if not all trials even when the head was restrained, even at very modest stimulus eccentricities. Exemplar data are shown in Fig. 2-3 by displaying the recruitment of right-OCI in monkey *je* while head-restrained with stimuli placed at 35° (Fig. 2-3 A) and at 10° (Fig. 2-3 B). Note the similarity in the patterning of neck muscle activity shortly after stimulus presentation with the data obtained with the head-unrestrained shown in Fig. 2-2. The increases in neck muscle activity in the peri-saccadic interval and following saccade end are consistent with

Figure 2-3. Recruitment of right-OCI in monkey *je* (i.e. same muscle as in Fig. 2) while head-restrained with stimuli placed at either 35° (A) or 10° (B). Same format as Fig. 2.

previous reports describing the tonic and phasic coupling of neck muscle activity with eye position (Lestienne et al., 1984; André-Deshays et al., 1991; Werner et al., 1997).

These results emphasize that the visual responses on neck muscles in an anti-saccade task persist both when the head is restrained, and at modest stimulus eccentricities similar to those used in behavioral and neuroimaging studies in both humans and monkeys (Amador et al., 1998; Bell et al., 2000; Koyama et al., 2004).

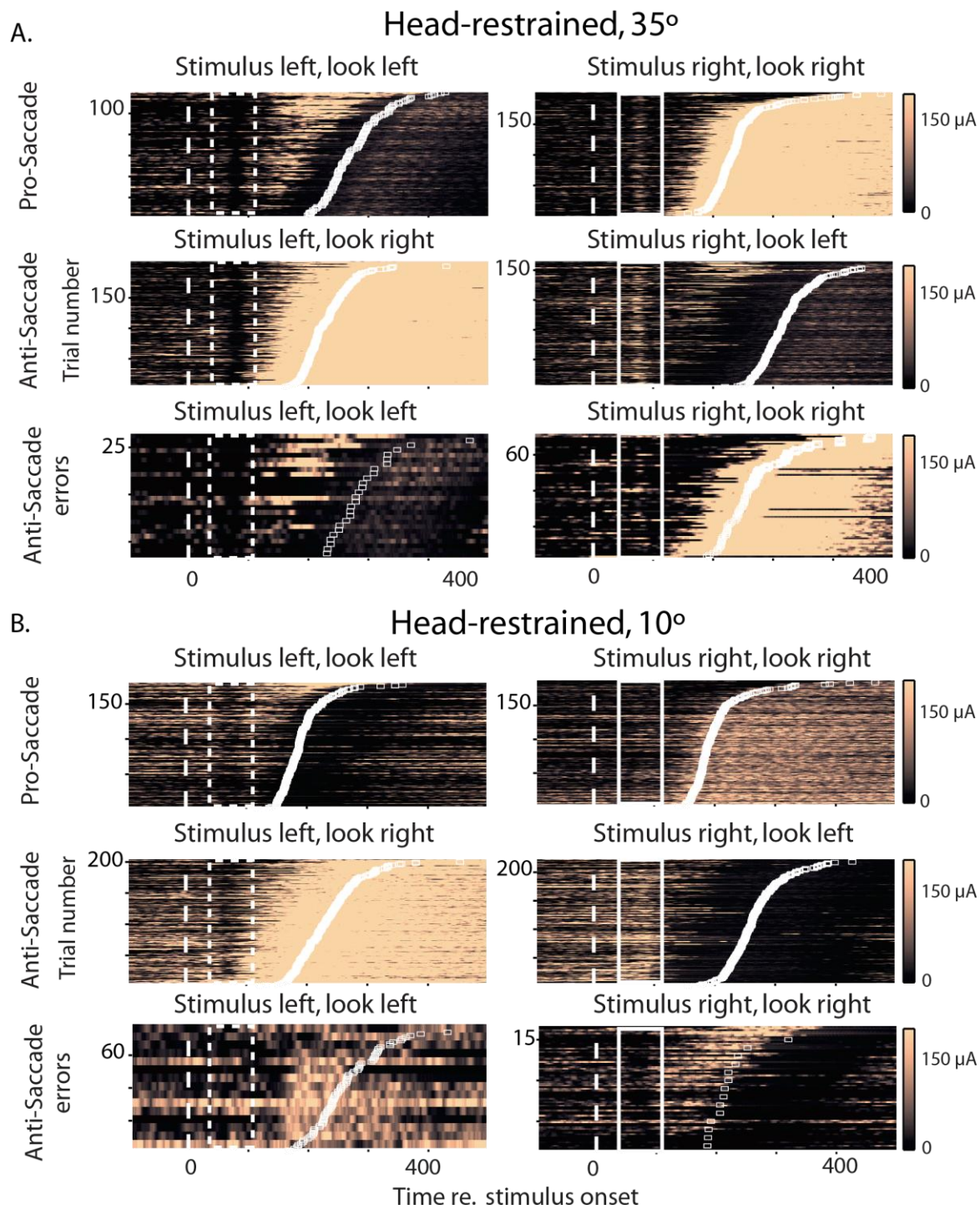

2.3.3 - Timing of visual response on neck muscles

To analyze the visual response on neck muscles, we employed a time-series ROC analysis (see Materials and methods). Our goal here is to determine when neck muscle activity discriminated the side of stimulus presentation (we term this the ‘discrimination time’; see Materials and methods). An example of this analysis is shown for the representative data recorded from right-OCI from monkey *je* (Fig. 2-4). To compare whether task instruction had any influence on discrimination time, we conducted separate time-series ROC analyses for data collected from pro- (Fig. 2-4 A/B) and anti-saccade (Fig. 2-4 C/D) trials. At each point in time, the ROC analysis derives a metric expressing the segregation of neck muscle activity depending on the side of stimulus presentation (a value of 0.5 indicates that neck muscle activity provides no information about the side of stimulus presentation, whereas values near 0.0 or 1.0 indicate that neck muscle activity is informative about the side of stimulus presentation). In Fig. 2-4 A, we represent the recruitment of right-OCI aligned to stimulus presentation in a pro-saccade trial. Note how ipsilateral (rightward) or contralateral (leftward) stimulus presentation elicited a transient increase or decrease in activity about 60 ms later, respectively, followed by a more sustained increase or decrease in activity for rightward or leftward movements, respectively. The corresponding time-series ROC analysis for these data displayed a sharp but temporary increase in the area under the ROC curve to values exceeding 0.6 (Fig. 2-4 B), followed by a more sustained increase in the ROC metric to values near 1.0. The discrimination time for the recruitment of right-OCI during pro-saccades was 64 ms (Fig. 2-4 B).

Figure 2-4. Depiction of analysis for determining the timing of the visual response on neck muscles, using the representative data shown in Fig. 2. (A/C) Stimulus-aligned EMG activity for both pro- and anti-saccades, depending on whether the monkey had to look to the right (black profiles) or left (gray profiles). Contours span the extent of the average \pm the standard error of the mean. Note the divergence of these traces starting about 65 ms after stimulus onset. (B/ D) Time-series receiver operating characteristic (ROC) analysis relative to stimulus onset, derived by computing the area under the ROC curve at each point in time. Note values fluctuate about 0.5 before and immediately after stimulus presentation, signifying that EMG activity did not provide any information about the side of stimulus presentation. ROC values subsequently increased to values $>$ 0.7 before increasing prior to pro-saccades (B), and decreasing prior to anti-saccade (D). OCI, obliquus capitis inferior.

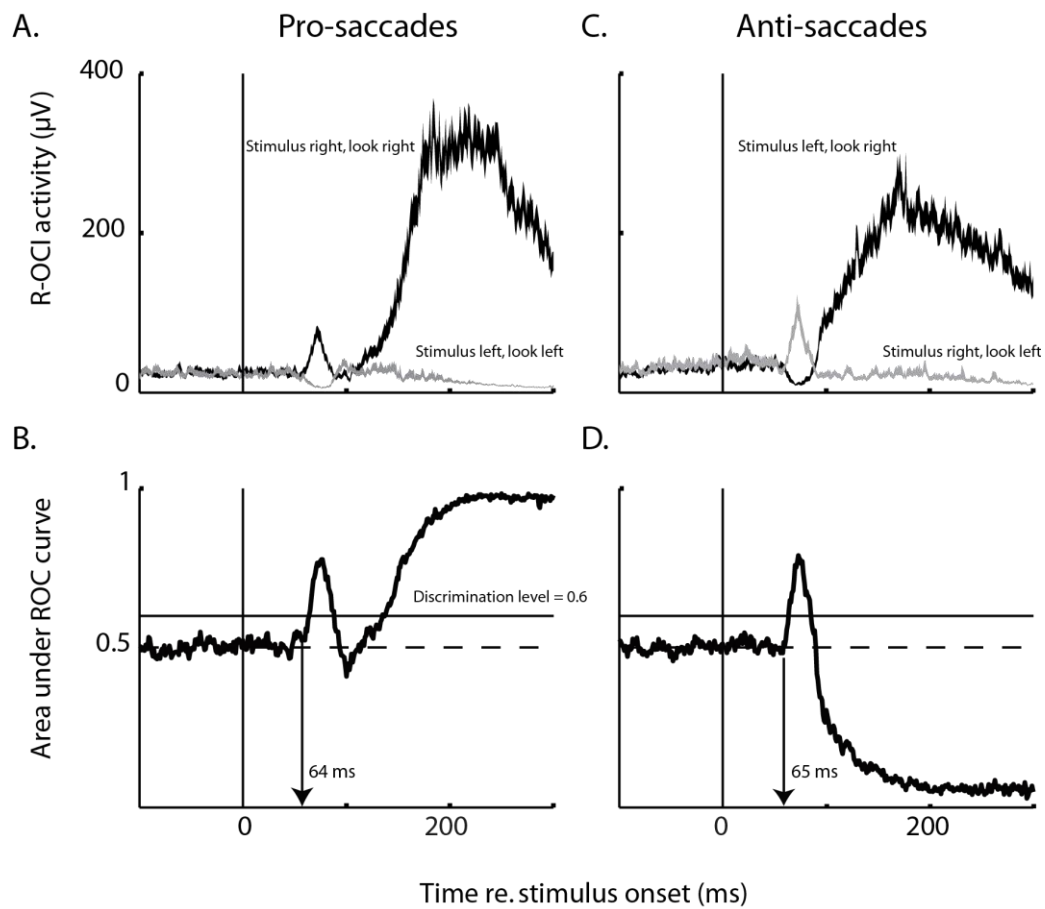

We conducted a similar analysis on right-OCI data recorded on anti-saccade trials (Fig. 2-4 C/D). Here, the increase or decrease in right-OCI activity following ipsilateral (rightward) or contralateral (leftward) stimulus presentation was short-lived, and was followed by a suppression or increase in activity for the leftward or rightward gaze shifts, respectively. Accordingly, the time-series ROC analysis of these data displayed a similarly transient increase in values about 0.6 before decreasing sharply to values below 0.1 for the remaining time (Fig. 2-4 D; this decrease in the ROC metric occurs as rightward stimulus presentation is followed by leftward movements). The discrimination time derived from these data was 65 ms.

Thus, for our representative dataset, the discrimination times derived from right-OCI activity were very similar regardless of whether the monkey was performing pro- or anti-saccade trials. We repeated this analysis across our sample, deriving the discrimination times for pro- and anti-saccade trials separately for any muscle at any given stimulus eccentricity in each monkey (recall we implanted both OCI and RCM bilaterally in each monkey. We treated each recording as an independent sample. Hence, the discrimination times derived for right-OCI from monkey *je* with stimuli at 35° were kept separate from those derived for l-RCM in monkey *je* at 35°, and right-OCI from monkey *gr* at 20°).

Across our sample, we observed no difference in the discrimination times on pro- vs. anti-saccade data (Fig. 2-5A; head-unrestrained pro-saccade discrimination times = 64.1 ± 7.7 ms; head-unrestrained anti-saccade discrimination times = 64.4 ± 9.6 ms; paired *t*-test, $t_{37} = -0.3$, $P = 0.7$). We also observed a strong correlation between these paired discrimination times, meaning that longer discrimination times from pro-saccade

trials tended to occur with longer discrimination times derived from anti-saccade trials ($R = 0.86$, $P = 10^{-4}$; Fig. 2-5 A). Further analysis of our sample also revealed differences between monkeys. On average, discrimination times were shorter for monkey *je* compared with monkey *gr* (monkey *je* discrimination time = 61.2 ± 7 ms; monkey *gr* discrimination times = 72.7 ± 5.7 ms, paired *t*-test, $t_{19} = -5.1$, $P = 10^{-4}$). Moreover, we observed slightly shorter discrimination times on anti- vs. pro-saccade trials for monkey *je* (60.5 ± 7.5 ms vs. 61.9 ± 6.9 ms, paired *t*-test, $t_{27} = 2.0$, $P = 0.04$), whereas slightly longer discrimination times were observed on anti- vs. pro-saccade trials for monkey *gr* (75.1 ± 6.4 vs. 70.3 ± 6.4 ms, paired *t*-test, $t_9 = -2.7$, $P = 0.02$).

In monkey *je* we observed no dependency of head-restraint on discrimination times (head-unrestrained discrimination times = 61.1 ± 9.4 ms; head-restrained discrimination times = 61.2 ± 4.9 ms; *t*-test, $t_{15} = -0.02$, $P = 0.98$).

Finally, we also examined how discrimination times varied with stimulus eccentricity. To do this, we averaged the discrimination time obtained for pro- and anti-saccade trials, and plotting this result as a function of stimulus eccentricity revealed a weakly increasing trend (Fig. 2-5 B; $r = 0.3$, $P = 0.05$).

In summary, although there were small idiosyncratic differences in our two monkeys, stimulus presentation in both produced a short-latency (< 100 ms) visual response on neck muscles in both pro- and anti-saccade trials. This visual response depended only weakly on stimulus eccentricity, and in monkey *je* persisted regardless of head-restraint.

2.3.4 - Comparative characteristics of visual response on neck muscles with trial type

We used the discrimination time to characterize and compare features of the visual response on neck muscles in pro- vs. anti-saccade trials. We measured the absolute magnitude of the visual response after the discrimination time, the level of background EMG activity prior to the discrimination time, and the increase in the visual response above background (we term this the ‘relative’ magnitude of the visual response).

EMG voltages are not directly comparable across different muscles given the variation in the impedances of individual electrodes. Because of this, we analyzed the characteristics of the visual responses by first calculating a unitless ‘modulation index’ as:

$$MI = (PRO - ANTI) / (PRO + ANTI)$$

Hence, MIs > 0 mean that a given measure was greater on pro- compared with anti-saccade trials. We calculated different MIs for the absolute magnitude of the visual response (Fig. 2-6 A), the background activity prior to the visual response (Fig. 2-6 B), and relative magnitude of the visual response above baseline (Fig. 2-6 C). These analyses revealed different patterns of neck muscle recruitment in the two monkeys depending on the top-down instruction to prepare for a pro- or anti-saccade.

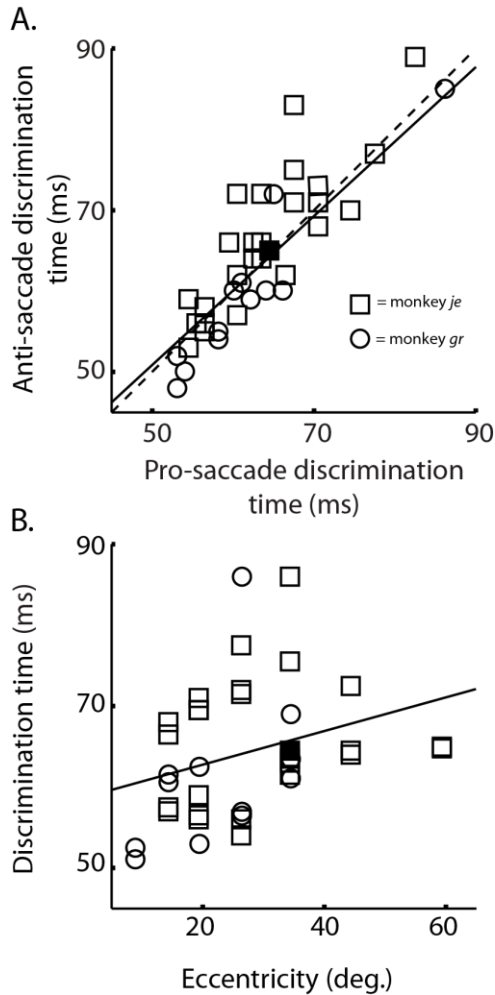
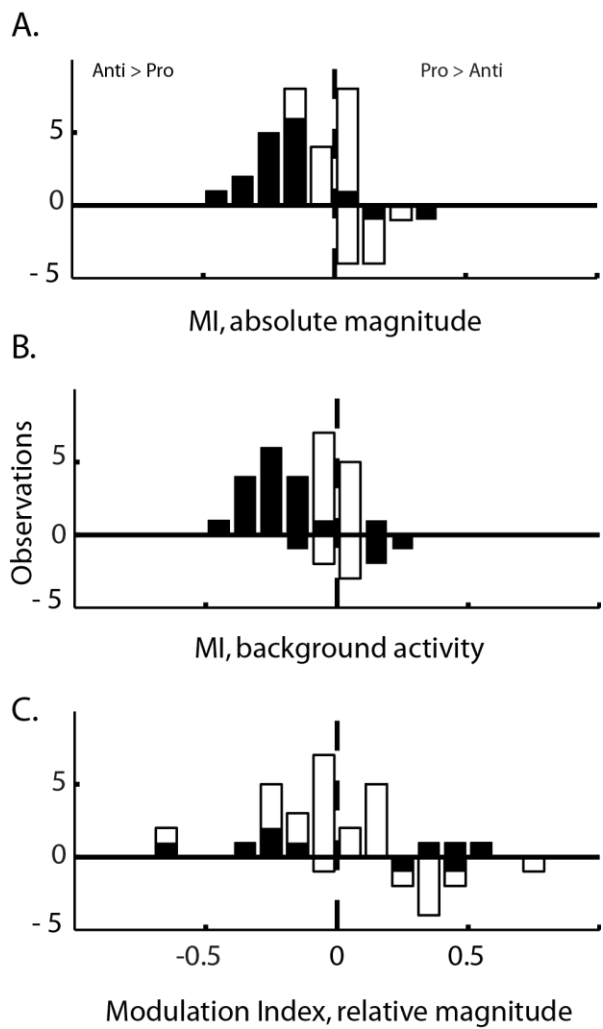

Figure 2-5. (A) Scatterplot of pro- and anti-saccade discrimination times. Each point represents data taken from a unique combination of monkey (*je* or *gr*), muscle (OCI or RCM), side (left or right) and eccentricity. The solid line shows regression line and the dashed line shows the line of unity. (B) Plot of discrimination time (averaged across pro- and anti-saccades) as a function of stimulus eccentricity. The solid line shows the regression line. Solid squares in (A) and (B) show data derived from exemplar data shown in Figs 2 and 4.

Figure 2-6. Modulation indices (MIs) characterizing features of neck muscle activity either during or preceding the visual response on neck muscles. Modulation indices calculated as $([PRO - ANTI]/[PRO + ANTI])$, for either the absolute magnitude of the visual response (A), background EMG activity preceding the visual response (B), or relative magnitude of the visual response above background (C). MIs greater than zero signify occurrences when the parameter was greater on pro- vs. anti-saccade trials. Each observation is taken from a unique combination of monkey (*je* in upper histograms, *gr* in lower histograms), muscle (OCI or RCM), side (left or right) and eccentricity. The colored portions of the histograms represent occurrences where the distribution of the parameter differed significantly across pro- and anti-saccade trials.



For example, the absolute magnitude of the visual response on neck muscles was greater for anti- vs. pro-saccade trials in monkey *je* (upper histogram, Fig. 2-6 A; -0.11 ± 0.14 ; t -test vs. zero, $t_{27} = -3.2$, $P = 10^{-4}$), but was greater for pro- vs. anti-saccade trials in monkey *gr* (downward histogram, Fig. 2-6 A; 0.13 ± 0.09 ; t -test vs. zero, $t_9 = 4.8$, $P = 10^{-4}$). A similar analysis of the background activity prior to the visual response revealed a significant skew to negative values for monkey *je*, but positive values for monkey *gr* (upper histogram, Fig. 2-6 B; -0.14 ± 0.16 ; t -test vs. zero, $t_{27} = -4.8$, $P = 0.01$; downward histogram, 0.08 ± 0.11 ; t -test vs. zero, $t_9 = 2.2$, $P = 0.05$). These observations suggest that the differences between the absolute magnitude of the visual response on pro- vs. anti-saccades may be attributable to pre-existing differences in the background level of neck EMG. Consistent with this, we observed no significant difference in the relative magnitude of the visual burst in monkey *je* (upper histogram, Fig. 2-6 C; -0.05 ± 0.27 ; t -test vs. zero, $t_{27} = -1.0$, $P = 0.3$), while the relative magnitude of the visual response was still skewed to positive values for monkey *gr* (downward histogram, Fig. 2-6 C; 0.36 ± 0.2 ; t -test vs. zero, $t_9 = 5.8$, $P = 0.01$).

To summarize these results, monkey *je* adopted a profile of neck muscle recruitment where the level of background activity was selectively greater at the time of the visual response on anti-saccade trials, which led to a greater absolute magnitude of the visual response. In monkey *gr*, both the background level of neck muscle activity and the relative magnitude of the visual response were greater on pro-saccade trials.

In monkey *je*, we also compared the values of these parameters across head-restraint. The modulation indices show that the magnitude of EMG activity was larger on anti-saccade trials regardless of head-restraint (head-restrained = -0.2 ± 0.1 , t -test vs.

zero, $t_{11} = -6.7$, $P = 0.001$; head-unrestrained = -0.04 ± 0.1 , t -test vs. zero, $t_{15} = -1.6$, $P = 0.1$). Background EMG activity values were skewed negatively regardless of head-restraint (head-restrained = -0.19 ± 0.1 , t -test vs. zero, $t_{11} = -6.4$, $P = 0.001$; head-unrestrained = -0.1 ± 0.1 , t -test vs. zero, $t_{15} = -2.3$, $P = 0.05$). Finally, the relative EMG magnitude was larger on anti-saccade trials when head-restrained, but larger on pro-saccade trials when head-unrestrained (head-restrained = -0.19 ± 0.2 , t -test vs. zero, $t_{11} = -2.4$, $P = 0.05$; head-unrestrained = 0.06 ± 0.2 , t -test vs. zero, $t_{15} = 1.1$, $P = 0.3$). These findings emphasize again that a qualitatively similar visual response on neck muscles is observed regardless of head-restraint.

2.3.5 - Emergence of top-down influences on neck EMG activity before stimulus presentation

The preceding analyses suggest that each monkey adopted an idiosyncratic strategy that led to different comparative levels of background neck muscle activity with task instruction. We now examine the timeline of such task-dependent activity during the interval that the task instruction is available (conveyed by the color of the FP). Accordingly, we focused on neck EMG activity recorded during an interval spanning from the time that the monkey entered the fixation window to the time of stimulus presentation. By the end of this interval, the monkeys have consolidated the instruction to execute either a pro- or anti-saccade, but cannot predict the side of stimulus presentation or the direction of the appropriate saccade. The timeline for how the modulation index of background EMG activity changes during this interval is shown in Fig. 2-7 (recall different fixation intervals were used for the two monkeys). For this analysis we pooled

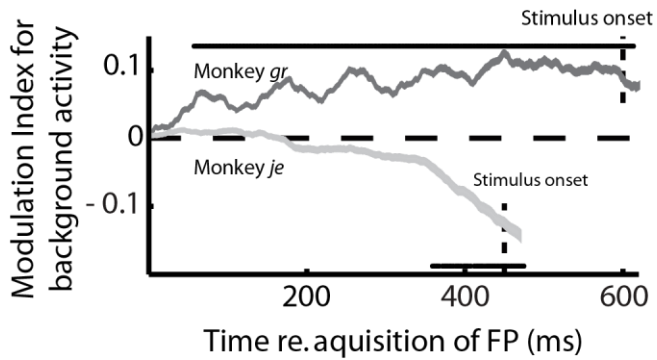

Figure 2-7. Time course of the change in neck muscle activity on pro- and anti-saccade trials during the fixation interval prior to the visual response on neck muscles. Values denoted as a modulation index, calculated as in Fig. 6. The time course of how the modulation index differed for monkey *je* compared with monkey *gr*. We first calculated the time course of the modulation index for each monkey independently at each eccentricity, and then pooled across all eccentricities to derive the contours (which show the area subtended by the standard error of the mean). The solid horizontal lines represent the time points where the modulation index was significantly different from 0 at the $P < 0.05$ level.

the background MIs across all stimulus eccentricities and muscles from a given monkey, hence the contours in Fig. 2-7 represent how the upper and lower histograms from Fig. 6B change through time. For monkey *je*, the modulation index for background activity was centered near zero for the first ~350 ms of the fixation interval (signifying no differential background activity for pro- vs. anti-saccade trials), but then decreased to significantly negative values in the final ~150 ms preceding stimulus onset (signifying greater levels of recruitment prior to anti-saccades). In contrast, the modulation index of background activity observed from monkey *gr* attained significantly positive values (signifying greater activity prior to pro-saccades) for most of the fixation interval.

2.3.6 - Background neck muscle activity reflects performance on anti-saccade trials

Anti-saccade errors occur when the subject makes an inappropriate pro-saccade to the peripheral stimulus, and we wondered whether neck muscle activity was related in any way to ensuing task performance. In light of the differences in the background levels of neck EMG during the fixation interval noted above, we predicted that the level of background activity preceding anti-saccade errors should resemble that observed during pro-saccades. This is what we observed.

To show this result, we present the comparative levels of background activity recorded from the two monkeys during pro-saccades, correct anti-saccades and erroneous anti-saccades (Fig. 2-8). For this analysis, EMG activity was normalized relative to the background level of activity on pro-saccades immediately preceding the visual response, and then pooled across all muscles for a given monkey. For monkey *je*, note that the selective increase in neck EMG activity late in the fixation interval is observed only

before correct anti-saccades. The profile of activity before erroneous anti-saccades is essentially indistinguishable from that recorded before pro-saccades. Similarly for monkey *gr*, the background neck EMG activity recorded prior to erroneous anti-saccades is very similar to that recorded prior to pro-saccades, with both being higher than the activity recorded prior to correct anti-saccades. Thus, despite the differences in the task-dependency of background activity in the two monkeys, a common observation in both monkeys is that the activity recorded prior to erroneous anti-saccades resembled that recorded prior to pro-saccades.

2.3.7 - Subtle head movements in response to stimulus presentation

Although our monkeys rarely generated head-only errors toward the stimulus on individual anti-saccade trials, a very subtle head movement toward the stimulus emerged when we pooled data across all trials within our sample. This head movement tendency, which fell well below our detection criteria, is best revealed by comparing velocity traces for pro- and anti-saccades that carry gaze to the same location (see Fig. 2-9 A–C for eye, head and gaze velocity traces from our exemplar data shown in Fig. 2-2). Recall from this example that the initial visual response on neck EMG was ipsilateral to stimulus presentation, and hence occurred on right or left muscles prior to rightward pro- or anti-saccades, respectively. A close analysis of head velocity (Fig. 9 B) following stimulus onset revealed a very subtle rightward drift of the head on pro-saccade trials, and a mirroring leftward drift on anti-saccade trials. As such head movements were very slow (< 5 °/s) and brief (< 100 ms), the overall amplitude of the movement (< 0.5) was far below our criteria for detecting head motion. Gaze (Fig. 2-9 C) remained stable during

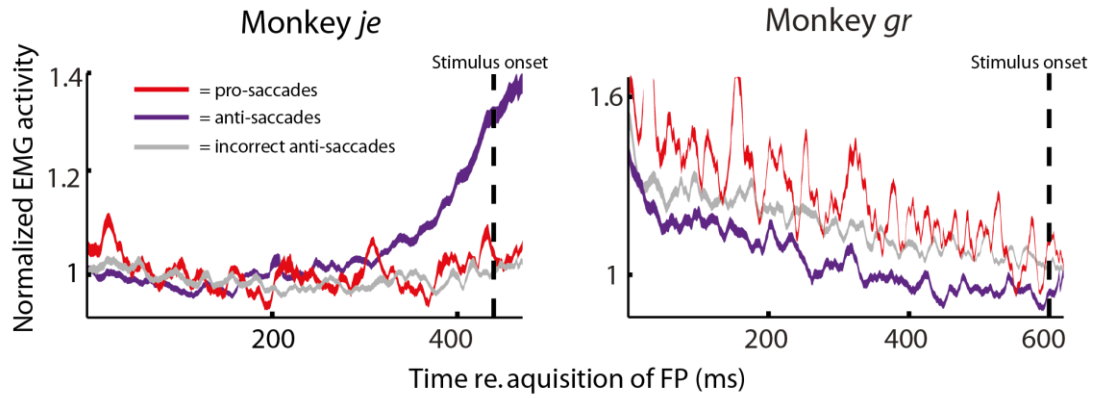
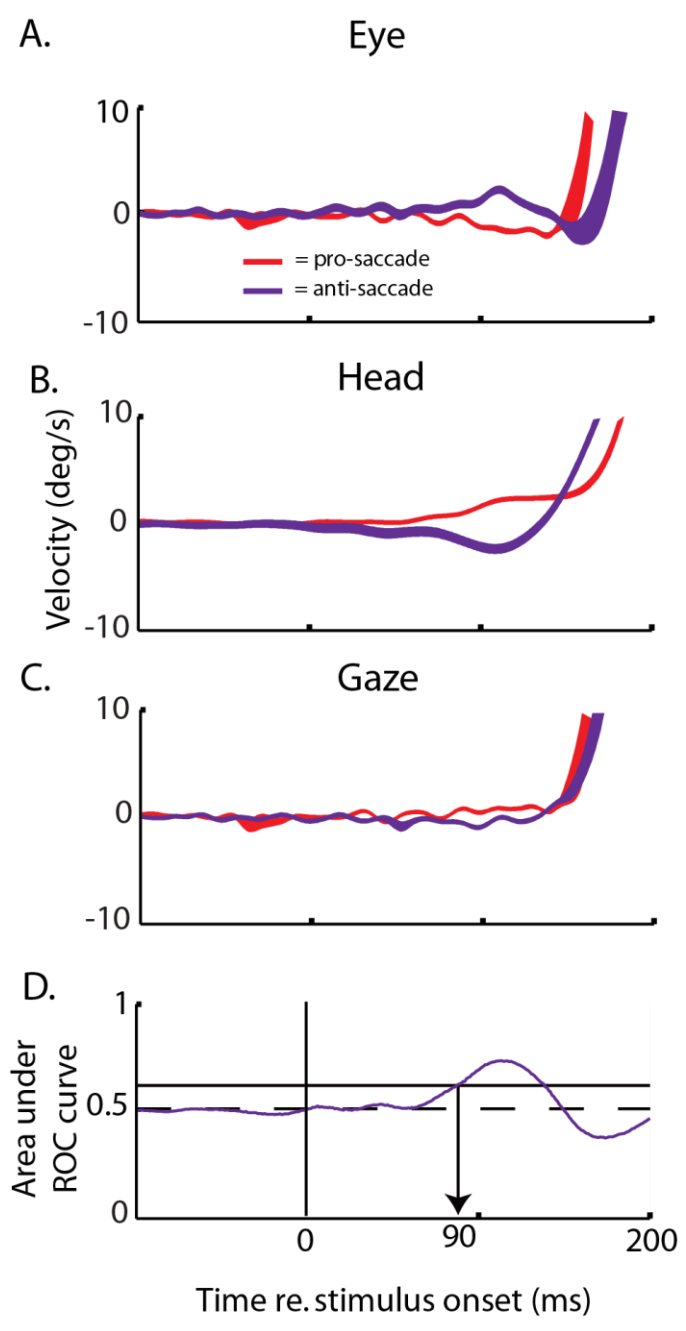

Figure 2-8. Plot of normalized EMG activity during the fixation interval, as a function of trial type and ensuing performance. Data were analyzed separately for each monkey, and first normalized to EMG activity on pro-saccade trials immediately prior to the visual response on neck muscles, before being pooled across all eccentricities (and head-restraint for monkey *je*). Contours show area subtended by the standard error of the mean.

Figure 2-9. Velocity traces in pro- and anti-saccade trials for eye (A), head (B) and gaze (C), derived from the same session in which the representative data shown in Fig. 2 were taken. Contours show the area subtended by the standard error of the mean. Trials requiring leftward gaze shifts were flipped prior to pooling. (D) Outcome of time-series receiver operating characteristic (ROC) analysis derived from head velocity traces, showing when head velocity differentiated between rightward and leftward-presented stimuli (same format as Fig. 4 B).



such small head movements due to a compensatory movement of the eye in the opposite direction (Fig. 2-9 A). Although such movements were small and slow, their consistency enabled us to quantify when head velocities diverged on pro- vs. anti-saccade trials. As above, we employed a time-series ROC approach, hereby asking when head velocity relative to stimulus presentation discriminated between pro- and anti-saccade trials. In this example, ROC values fluctuated by about 0.5 prior to and immediately after stimulus presentation, and then increased to values >0.6 about 90 ms after stimulus presentation (Fig. 2-9 D). In this example, we defined the discrimination time as the time where the ROC value exceeded 0.6, which occurred 88 ms after stimulus presentation (recall from Figs 2-2 and 2-3 that the activity of right-OCI discriminated the side of stimulus presentation 64 ms later).

We repeated this analysis across both monkeys and all stimulus eccentricities, pooling the data across the side of stimulus presentation at each eccentricity. Across our sample, head velocity discrimination times averaged 96 ± 13 ms (range: 87–129 ms), and occurred at all stimulus eccentricities except for 15° for monkey *gr*. Head velocity discrimination times were significantly less for monkey *je* (89 ± 1 ms) compared with monkey *gr* (106 ± 15 ms, *t*-test, $t_9 = -2.88$, $P = 0.02$). Head movement discrimination times increased significantly with stimulus eccentricity in monkey *gr* ($r = 0.99$, $P = 0.001$), but not monkey *je* ($P = 0.12$). In both monkeys, the discrimination times for neck muscles led that for head velocity by ~ 20 ms (monkey *je*– 24 ± 6 ms; monkey *gr*– 21 ± 5 ms), consistent with a causal role for the visual response on neck muscles in this very small acceleration of the head.

2.4 - DISCUSSION

We recorded neck muscle activity while monkeys performed an anti-saccade task, and observed a transient expression of a head-turning synergy that emerged ~60–70 ms after stimulus presentation. Importantly, this recruited motor program favored a head turn in the wrong direction and occurred on virtually every trial, regardless of head-restraint and modest stimulus eccentricity. Despite idiosyncratic differences in task-related activity, neck muscle activity in both monkeys on erroneous anti-saccade trials resembled that recorded during pro-saccade trials. Thus, aspects of neck muscle recruitment reflected bottom-up processes related to stimulus presentation and the top-down consolidation of task instruction. These results provide a new perspective on the circuits engaged during the anti-saccade task, emphasizing a much closer association with motor circuits than previously speculated.

2.4.1 - Potential neural circuits mediating bottom-up and top-down aspects of neck muscle recruitment

First, we consider potential neural circuits that could mediate our results. Visual responses on neck muscles resembled those observed in visually guided (Corneil et al., 2004) and inhibition-of-return (Corneil et al., 2008) paradigms, appearing on muscles ipsilateral to the side of stimulus presentation. Although numerous areas in the oculomotor cortex respond to visual stimulus presentation (Schmolesky et al., 1998; Bisley et al., 2004), it is likely that the intermediate layers of the superior colliculus (iSC) relay such information to the cephalomotor system. iSC neurons display a time-locked response to contralateral stimulus presentation prior to correctly performed anti-saccades

before the motor command develops in the other iSC (Everling et al., 1999). Transient visual responses are observed in efferent iSC neurons contributing to the pre-dorsal bundle that projects to premotor head areas (Rodgers et al., 2006). iSC neurons also discriminate the side of a visual stimulus ~10 ms before simultaneously recorded neck muscles (Rezvani & Corneil, 2008), consistent with the efferent lag from the iSC (Guitton et al., 1980; Corneil et al., 2002).

We can be confident that analogous visual responses are not developed on extraocular muscles. Momentary changes in the activity of extraocular motoneurons are sufficient to produce detectable eye motion (Sparks et al., 2002), and the duration of the visual response on neck muscles was ~20 ms (equivalent to the duration of a 2–3° saccade). Any eye-in-head motion we did observe compensated for small motion of the head toward the stimulus. The presence or absence of transient visual responses on neck or extraocular muscles, respectively, attests to differences in premotor control. We and others have speculated that the selective influence of omni-pause neurons (OPNs) on eye but not head premotor centers enact such differential control (Galiana & Guitton, 1992; Corneil et al., 2004; Gandhi & Sparks, 2007). We note that OPNs can also display a transient visual response ~60 ms following stimulus presentation (Everling et al., 1998), presumably increasing OPN-mediated inhibition of the saccadic burst generator. In contrast, the neural circuit(s) mediating neck muscle activity that reflects task instruction likely does not involve the iSC. Rostrally located iSC neurons active during stable fixation display greater activity prior to anti-saccades (Everling et al., 1999), resembling the task-related neck muscle activity seen in monkey *je*. However, the projection from the iSC to neck muscles is extremely weak or absent (Roucoux et al., 1980; Corneil et al.,

2002; Hadjidimitrakis et al., 2007). In contrast, caudally located movement-related iSC neurons are more active prior to pro-saccades (Everling et al., 1999), resembling the profile of neck muscle recruitment observed in monkey *gr*. However, neck muscle activity best reflects the differential distribution of activity in both iSCs (Rezvani & Corneil, 2008). Assuming that movement-related neurons in both iSCs increase equally prior to the presentation of the stimulus on pro-saccade trials, there should not be any increase in neck muscle recruitment.

Descending pathways taking origin from frontal cortices appear capable of relaying high-level signals to the motor periphery (Roesch & Olson, 2003). Activity in numerous frontal and associated thalamic areas differs when monkeys prepare for a pro- or an anti-saccade, frequently predicting task performance (Everling & Munoz, 2000; Amador et al., 2004; Johnston & Everling, 2006; Johnston et al., 2007; Kunitatsu & Tanaka, 2010). A diversity of studies employing multiple methodologies have implicated many of these areas in the control of orienting head movements in both humans and monkeys (Bizzi & Schiller, 1970; van der Steen et al., 1986; Tu & Keating, 2000; Martinez-Trujillo et al., 2003; Petit & Beauchamp, 2003; Chen & Walton, 2005; Elsley et al., 2007; Knight & Fuchs, 2007; Boulanger et al., 2009; Tark & Curtis, 2009). Although circumstantial, it appears likely that some of these areas could mediate the aspects of neck muscle recruitment reflective of task instruction.

2.4.2 - Blurring the sensorimotor transformation for anti-saccades

Performance in the anti-saccade task has been conceptualized as a race between two competing motor processes to threshold – a congruent process encoding a pro-saccade toward a stimulus, and an incongruent process encoding an anti-saccade in the opposite direction (Munoz & Everling, 2004; Kristjansson, 2007). Such models have proven useful in explaining performance in normal subjects and in a variety of clinical populations. Inherent to this conceptualization is a serial nature of processing, whereby the commitment to make either an erroneous pro-saccade or correct anti-saccade is relayed to the motor periphery only after the threshold has been exceeded. Such a discrete segregation between competition and motor execution does not extend to orienting head movements. Instead, the presence of neck muscle activity in response to stimulus onset and reflective of task consolidation suggests a more parallel nature to sensorimotor processing, integrating with the motor periphery.

The premotor mechanisms orienting the head are intimately associated with the oculomotor system. It is only downstream of the iSC that gaze shift programs are segregated into the component eye-in-head and head-on-body commands (Freedman et al., 1996; Freedman & Sparks, 1997). Visual responses on neck muscles demonstrate that the oculomotor system delivers an orienting motor program to neck muscles essentially as soon as it is available, even while the competition between pro- and anti-saccades is ongoing. As mentioned above, the tecto-reticulo-spinal pathway is a likely candidate for relaying visual information onto the neck. What is not clear is which pathways carry the visual signal to the iSC prior to anti-saccades. On one hand, antidromic studies show that the frontal eye fields and lateral intraparietal area are likely candidates for relaying visual

information to the iSC (Wurtz et al., 2001). However, saccades evoked by stimulation in the frontal eye fields are not biased toward a visual stimulus before the generation of anti-saccades (Juan et al., 2004), as would have been expected if the visual response within the frontal eye field interacted functionally with the iSC. Regardless of the precise pathway, it is clear that visual transients within the oculomotor system influence the motor periphery.

2.4.3 - Biomechanical consequences of the visual response on neck muscles

The study of head-unrestrained anti-saccades provides an opportunity to investigate the biomechanical consequences of the visual response on neck muscles without confounds inherent in other paradigms. In the original report of visual responses of neck EMG (Corneil et al., 2004), monkeys generated visually guided saccades, hence the transient visual response was followed by a larger and more sustained period of recruitment (i.e. Fig. 2A). Although small head movements toward a briefly-flashed cue were observed during an inhibition-of-return paradigm (Corneil et al., 2008), the transient visual response to the cue was also followed by ~200 ms of tonic recruitment.

In contrast, the visual response on neck muscles during the anti-saccade task was not followed by more sustained levels of neck muscle recruitment. As in humans (Chapman & Corneil, 2008), monkeys generated very few head-only errors, suggesting that the brief visual response of neck EMG did not result in head motion detectable on individual trials. However, thresholds for head movements are difficult to quantify (Chen & Walton, 2005), and detailed analytical methods are required to reveal subtle head

movement tendencies across a sample of trials (Oommen & Stahl, 2005). A subtle influence of the visual response of neck EMG on head kinematics was revealed only after pooling head velocity traces across all pro- and anti-saccade trials (Fig. 9).

2.4.4 - Summary

Our results suggest that the processes underlying task set and stimulus detection manifest in the cephalomotor periphery. When placed alongside results demonstrating neck muscle recruitment following sub-saccadic stimulation (Corneil et al., 2010) or preparation (Rezvani & Corneil, 2008) within the oculomotor system, it becomes clear that stability of the gaze axis during covert processes cannot be used to infer the absence of motor recruitment. Recent results in the limb-movement literature have also supported the idea that presentation of stationary or moving visual stimuli can initiate reflexive recruitment of proximal limb muscles in cats, monkeys and humans (Schepens & Drew, 2003; Saijo et al., 2005; Fautrelle et al., 2010; Perfiliev et al., 2010; Pruszynski et al., 2010). Together, these results suggest that the earliest recruitment of the motor periphery following stimulus presentation arises not from a voluntary decision to initiate an action, but rather from activation of hard-wired circuits that target postural or proximal muscles. Such a strategy appears to generalize to multiple inertial-laden systems.

Reference List

- Amador N, Schlag-Rey M, Schlag J (2004) Primate antisaccade. II. Supplementary eye field neuronal activity predicts correct performance. *J Neurophysiol* 91:1672-1689
- Andersen RA, Asanuma C, Essick G, Siegel RM (1990) Corticocortical connections of anatomically and physiologically defined subdivisions within the inferior parietal lobule. *J Comp Neurol* 296:65-113
- Bruce CJ, Goldberg ME (1985) Primate frontal eye fields. I. Single neurons discharging before saccades. *J Neurophysiol* 53:603-635
- Bruce CJ, Goldberg ME, Bushnell MC, Stanton GB (1985) Primate frontal eye fields. II. Physiological and anatomical correlates of electrically evoked eye movements. *J Neurophysiol* 54:714-734
- Chen LL, Walton MM (2005) Head movement evoked by electrical stimulation in the supplementary eye field of the rhesus monkey. *J Neurophysiol* 94:4502-4519
- Corneil BD, Munoz DP, Chapman BB, Admans T, Cushing SL (2008) Neuromuscular consequences of reflexive covert orienting. *Nat Neurosci* 11:13-15
- Corneil BD, Olivier E, Munoz DP (2004) Visual responses on neck muscles reveal selective gating that prevents express saccades. *Neuron* 42:831-841

DeSouza JF, Menon RS, Everling S (2003) Preparatory set associated with pro-saccades and anti-saccades in humans investigated with event-related fMRI. *J Neurophysiol* 89:1016-1023

Dias EC, Bruce CJ (1994) Physiological correlate of fixation disengagement in the primate's frontal eye field. *J Neurophysiol* 72:2532-2537

Dorris MC, Paré M, Munoz DP (1997) Neuronal activity in monkey superior colliculus related to the initiation of saccadic eye movements. *J Neurosci* 17:8566-8579

Everling S, DeSouza JF (2005) Rule-dependent activity for prosaccades and antisaccades in the primate prefrontal cortex. *J Cogn Neurosci* 17:1496

Everling S, Dorris MC, Klein RM, Munoz DP (1999) Role of primate superior colliculus in preparation and execution of anti-saccades and pro-saccades. *J Neurosci* 19:2740-2754

Everling S, Dorris MC, Munoz DP (1998) Reflex suppression in the anti-saccade task is dependent on prestimulus neural processes. *J Neurophysiol* 80:1584-1589

Everling S, Munoz DP (2000) Neuronal correlates for preparatory set associated with pro-saccades and anti-saccades in the primate frontal eye field. *J Neurosci* 20:387-400

Ford KA, Gati JS, Menon RS, Everling S (2009) BOLD fMRI activation for anti-saccades in nonhuman primates. *Neuroimage* 45:470-476

- Ford KA, Goltz HC, Brown MR, Everling S (2005) Neural processes associated with antisaccade task performance investigated with event-related FMRI. *J Neurophysiol* 94:429-440
- Fries W (1984) Cortical projections to the superior colliculus in the macaque monkey: a retrograde study using horseradish peroxidase. *J Comp Neurol* 230:55-76
- Fuchs AF, Kaneko CR, Scudder CA (1985) Brainstem control of saccadic eye movements. *Annu Rev Neurosci* 8:307-337
- Funahashi S, Chafee MV, Goldman-Rakic PS (1993) Prefrontal neuronal activity in rhesus monkeys performing a delayed anti-saccade task. *Nature* 365:753-756
- Gandhi NJ, Keller EL (1997) Spatial distribution and discharge characteristics of superior colliculus neurons antidromically activated from the omnipause region in monkey. *J Neurophysiol* 78:2221-2225
- Goldman PS, Nauta WJ (1976) Autoradiographic demonstration of a projection from prefrontal association cortex to the superior colliculus in the rhesus monkey. *Brain Res* 116:145-149
- Gottlieb J, Goldberg ME (1999) Activity of neurons in the lateral intraparietal area of the monkey during an antisaccade task. *Nat Neurosci* 2:906-912
- Guioton D, Volle M (1987) Gaze control in humans: eye-head coordination during orienting movements to targets within and beyond the oculomotor range. *J Neurophysiol* 58:427-459

Hall WC, Moschovakis A (2004) *The Superior Colliculus: New approaches for studying sensorimotor integration*. CRC Press, Boca Raton, FL

Hallett PE (1978) Primary and secondary saccades to goals defined by instructions. *Vision Res* 18:1279-1296

Hardy SG (1986) Projections to the midbrain from the medial versus lateral prefrontal cortices of the rat. *Neurosci Lett* 63:159-164

Leichnetz GR, Spencer RF, Hardy SG, Astruc J (1981) The prefrontal corticotectal projection in the monkey; an anterograde and retrograde horseradish peroxidase study. *Neuroscience* 6:1023-1041

Leigh RJ, Zee DS (2006) *The neurology of eye movements*. Oxford University Press,

Moschovakis AK, Karabelas AB, Highstein SM (1988) Structure-function relationships in the primate superior colliculus. II. Morphological identity of presaccadic neurons. *J Neurophysiol* 60:263-302

Munoz DP, Dorris MC, Paré M, Everling S (2000) On your mark, get set: brainstem circuitry underlying saccadic initiation. *Can J Physiol Pharmacol* 78:934-944

Munoz DP, Everling S (2004) Look away: the anti-saccade task and the voluntary control of eye movement. *Nat Rev Neurosci* 5:218-228

Munoz DP, Istvan PJ (1998) Lateral inhibitory interactions in the intermediate layers of the monkey superior colliculus. *J Neurophysiol* 79:1193-1209

- Munoz DP, Schall JD (2003) In: Hall WC, Moschovakis A (eds) *The Superior Colliculus: New approaches for studying sensorimotor integrations*. CRC, Boca Raton, Florida, pp 55-82
- Munoz DP, Wurtz RH (1995) Saccade-related activity in monkey superior colliculus. I. Characteristics of burst and buildup cells. *J Neurophysiol* 73:2313-2333
- Olson CR, Gettner SN (2002) Neuronal activity related to rule and conflict in macaque supplementary eye field. *Physiol Behav* 77:663-670
- Robinson DA (1972) Eye movements evoked by collicular stimulation in the alert monkey. *Vision Res* 12:1795-1808
- Sato TR, Schall JD (2003) Effects of stimulus-response compatibility on neural selection in frontal eye field. *Neuron* 38:637-648
- Schlag J, Schlag-Rey M (1985) Unit activity related to spontaneous saccades in frontal dorsomedial cortex of monkey. *Exp Brain Res* 58:208-211
- Schlag J, Schlag-Rey M (1987) Evidence for a supplementary eye field. *J Neurophysiol* 57:179-200
- Schlag-Rey M, Amador N, Sanchez H, Schlag J (1997) Antisaccade performance predicted by neuronal activity in the supplementary eye field. *Nature* 390:398-401
- Scudder CA, Kaneko CS, Fuchs AF (2002) The brainstem burst generator for saccadic eye movements: a modern synthesis. *Exp Brain Res* 142:439-462

- Scudder CA, Moschovakis AK, Karabelas AB, Highstein SM (1996) Anatomy and physiology of saccadic long-lead burst neurons recorded in the alert squirrel monkey. I. Descending projections from the mesencephalon. *J Neurophysiol* 76:332-352
- Selemon LD, Goldman-Rakic PS (1988) Common cortical and subcortical targets of the dorsolateral prefrontal and posterior parietal cortices in the rhesus monkey: evidence for a distributed neural network subserving spatially guided behavior. *J Neurosci* 8:4049-4068
- Shook BL, Schlag-Rey M, Schlag J (1990) Primate supplementary eye field: I. Comparative aspects of mesencephalic and pontine connections. *J Comp Neurol* 301:618-642
- Sparks DL, Hartwich-Young R (1989) The deep layers of the superior colliculus. *Rev Oculomot Res* 3:213-255
- Stuphorn V, Taylor TL, Schall JD (2000) Performance monitoring by the supplementary eye field. *Nature* 408:857-860
- Syka J, Radil-Weiss T (1971) Electrical stimulation of the tectum in freely moving cats. *Brain Res* 28:567-572
- Toth LJ, Assad JA (2002) Dynamic coding of behaviourally relevant stimuli in parietal cortex. *Nature* 415:165-168

Wurtz RH, Goldberg ME (1972) Activity of superior colliculus in behaving monkey. 3.

Cells discharging before eye movements. *J Neurophysiol* 35:575-586

Zhang M, Barash S (2000) Neuronal switching of sensorimotor transformations for

antisaccades. *Nature* 408:971-975

Zhang M, Barash S (2004) Persistent LIP activity in memory antisaccades: working

memory for a sensorimotor transformation. *J Neurophysiol* 91:1424-1441

Chapter 3

Neck muscle recruitment following stimulation of the primate supplementary eye fields

Brendan B. Chapman¹, Michael Pace, Sharon Cushing and Brian D. Corneil¹⁻³

Graduate Program in Neuroscience¹
Departments of Physiology & Pharmacology² and Psychology³,
University of Western Ontario,
London, Ontario, Canada N6A 5C1

ABSTRACT

The supplementary eye fields (SEF), located in the dorso-medial portion of the frontal cortex, and are thought to serve as an interface between high- and low-level aspects of motor performance. Reports suggest that the SEF is involved in the generation of saccades and eye-head gaze shifts, emphasizing this area's relationship with the oculomotor system. The goal of the current experiment is to examine neck muscle recruitment following stimulation of the SEF.

EMG activity was recorded from multiple turner and extensor neck muscles following electrical stimulation of the SEF (100 μ A, 150-300ms, 300 Hz). Monkeys were required to make a gaze shift from a central location to one of eight potential targets in both the head-restrained and head-unrestrained conditions. SEF stimulation occasionally resulted in overt gaze shifts and/or head only movements and consistently evoked a contralateral head turning synergy. Neck muscle responses i) began well in advance of evoked gaze shifts, ii) started earlier and attained a larger magnitude when accompanied by a gaze shift, and iii) persisted on trials without an overt gaze shift. The patterns of evoked neck muscle responses and eye-head gaze shifts resembled those evoked by frontal eye field (FEF) stimulation, with the exception that response latencies from the SEF were considerably longer (~10 ms). This basic description of the cephalomotor command evoked by SEF stimulation suggests that this structure, while further removed from the motor periphery than the FEF, taps into premotor orienting circuits in the brainstem in a similar manner.

3.1 – INTRODUCTION

The monkey supplementary eye fields (SEF) are cortical areas located in the dorso-medial frontal cortex. Anatomical studies suggest a role for the SEF in producing saccadic eye movements based on direct connections to premotor nuclei that control saccades as well as connections to other oculomotor areas such as the frontal eye fields (FEF) and superior colliculus [SC (Shook et al. 1990; Shook et al. 1991; Amiez and Petrides 2009)]. Consistent with this, microstimulation of the SEF reliably elicits contralateral saccadic eye movements (Tehovnik and Lee 1993; Huerta M.F. and Kaas J.H. 1990; Schlag and Schlag-Rey 1987; Russo and Bruce 1993; Schall 1991a; Fujii et al. 1995). Recordings within the SEF have not only demonstrated sensory and motor signals (Russo and Bruce 2000; Russo and Bruce 1996; Schall 1991b), but also suggested a role for the SEF in numerous cognitive and contextual processes related to spatial selectivity, errors, representation of movement plan, ordinal position selectivity, reward value and mapping new stimulus-response associations (Moorman and Olson 2007; Stuphorn et al. 2000; Schall et al. 2002; So and Stuphorn 2010; Chen and Wise 1995; Campos et al. 2009; Berdyeva and Olson 2010; Fujii et al. 2002; Coe et al. 2002). The current consensus is that the SEF, like other supplementary motor areas, serves as a critical interface between cognition and action (Nachev et al. 2008).

Although well-studied with the head restrained, a potential role for the SEF in head-unrestrained gaze shifts has only recently begun to be addressed. Initial studies showed that SEF stimulation did not reliably evoke head motion (Penfield 1950; Smith 1949; Schlag and Schlag-Rey 1987), but more recent systematic explorations of this structure have demonstrated that eye-head gaze shifts can be reliably evoked by SEF

stimulation (Chen and Walton 2005; Martinez-Trujillo et al. 2003; Martinez-Trujillo et al. 2003; Martinez-Trujillo et al. 2004). These studies have demonstrated that the head can make a significant contribution to gaze shifts evoked from the SEF, doing so with kinematics that resemble those observed during volitional eye-head gaze shifts (Martinez-Trujillo et al. 2003). Despite the head's substantial inertia, head movements evoked from the SEF frequently start around the time of the gaze shift, sometimes even preceding gaze shift onset (Chen and Walton 2005). Depending on the initial position of the eyes and head, SEF stimulation can also evoke head-only movements contralateral to the side of stimulation (Chen and Walton 2005). Finally, eye-head gaze shifts evoked from the SEF appear to be encoded in a variety of reference frames (Martinez-Trujillo et al. 2004), potentially indicating a role for the SEF in implementing arbitrary reference frame transformations.

This paper is the first study in a series designed to provide further information about the nature of the cephalomotor command evoked by SEF stimulation. Here, we will pair recordings of neck muscle activity with SEF stimulation, paralleling similar experiments performed in the frontal eye fields [FEF; (Elsley et al. 2007)], superior colliculus [SC (Corneil et al. 2002b; Corneil et al. 2002a)] and interstitial nucleus of Cajal [INC; (Farshadmanesh et al. 2008)]. Pairing neck muscle recordings with SEF stimulation will allow us to quantify the spatial aspects (i.e., which muscles) and temporal aspects (i.e., timing of muscle recruitment) of neck muscle responses evoked by SEF stimulation, at a resolution surpassing what can be gained from examining the kinematics of evoked head movements. In order to enable comparison with similar data obtained from the FEF and to reduce the confounding relationship between neck muscle

activity and eye position (Andre-Deshays et al. 1988; Corneil et al. 2002a), we chose to deliver stimulation while monkeys are looking straight ahead, just prior to the requirement to make a saccade in one of eight possible directions. Similar to results obtained from the FEF (Elsley et al. 2007), we observed robust recruitment of a head-turning synergy at almost all SEF sites. This recruitment reliably preceded gaze shift onset, and persisted on trials where stimulation failed to evoke a gaze shift. Unlike the FEF however, the latency of the evoked response was considerably longer than the conduction and synaptic delays of the shortest path to the motor periphery. Future studies will describe how this the basic evoked response is 1) modified across different initial positions, in order to better understand the neuromuscular basis of convergent responses evoked from the SEF and 2) dependent on the behavioral state of the animal at the time of stimulation. Portions of this manuscript have been presented in abstract format elsewhere (Chapman et al. 2010).

3.2 – METHODS

3.2.1 - Subjects and surgical procedures

Two male monkeys (*Macaca mulatta*, monkeys S and Z), weighing 12-14 kgs were used in this experiment. All training, surgical and experimental procedures were conducted in accordance with the Canadian Council on Animal Care policy on the use of laboratory animals and approved by the Animal Use Subcommittee of the University of Western Ontario Council on Animal Care (see appendix 1). The monkey's health and weight were monitored daily by technicians and/or veterinarians at the university.

Each animal underwent two surgeries. Details of both surgeries are provided elsewhere (Elsley et al. 2007). The goal of the first surgery was to prepare the animals for the chronic recording of gaze and head position. This included anchoring a head post to permit head restraint and implanting a scleral search coil to monitor gaze (eye-in-space) position. In addition, a recording cylinder was placed near midline over the frontal lobes to allow for extracellular recording and microstimulation of the SEF (Stereotaxic coordinates: Monkey S; AP = 25, ML = 3. Monkey Z; AP = 24, ML = 2). The second surgery was conducted to implant chronically indwelling bipolar hook electrodes bilaterally in five pairs of neck muscles used to orient the head both horizontally and vertically. These include the obliquus capitis inferior (OCI), rectus capitis posterior major (RCM) and splenius capitis (SP), which primarily contribute to horizontal head turns, and the extensors biventer cervicis (BC) and complexus (COM, See Fig.3-1) muscles, which primarily serve to pitch the head upward (Corneil et al. 2001).

3.2.2 - Microstimulation parameters

To qualify as a valid SEF site, stimulation had to evoke eye movements from anywhere in the visual field on more than 50% of all trials. Microstimulation was delivered through tungsten microelectrodes (0.5-1.2 M Ω at 1 KHz) lowered through a 23-gauge guide tube which did not pierce the dura and were secured within a Delrin grid. Stimulation consisted of a train of biphasic stimulation pulses (cathodal first) delivered at a frequency of 300 Hz. Each individual pulse was 0.3 ms in duration, and the biphasic

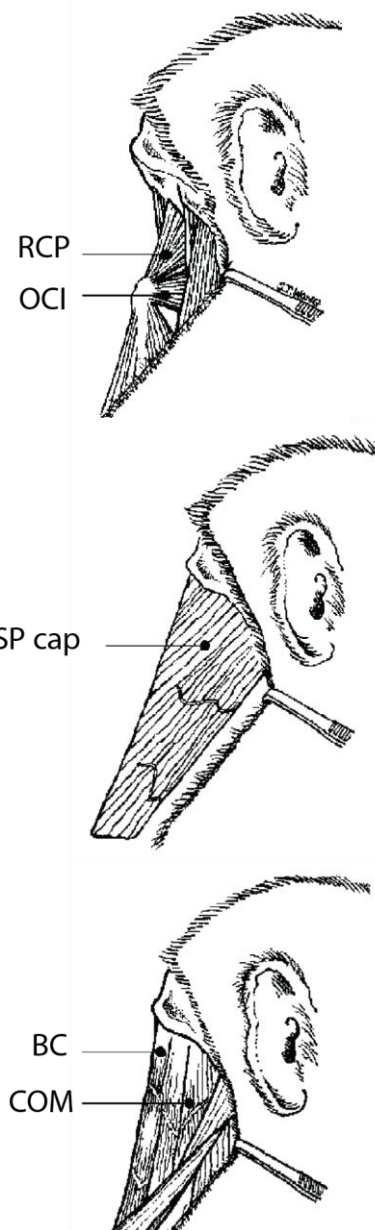

Figure 3-1. A: schematic drawings of the five neck muscles that were bilaterally implanted. OCI, obliquus capitis inferior; RCM, rectus capitis posterior major; SP, splenius capitis; BC, biventer cervicis; COM, complexus.

pulses were separated by 0.1 ms. Although we did not specifically measure strength-duration relationships, our pulse duration was above the minimum chronaxie measurement in cortex that elicits a saccade (Tehovnik et al. 2006). Stimulation current was fixed at 100 μ A. This level is slightly below currents used to define the SEF (Schlag and Schlag-Rey 1987) but above levels in other studies (Tehovnik and Lee 1993). Stimulation duration ranged between 150-300 ms., with longer duration occasionally needed in the head-unrestrained preparation to ensure eye-head gaze shifts were realized. We could collect multiple sets of data from a single grid location. A minimum of seven days was required between sampling of a grid location and subsequently returning to it. When multiple data sets were collected in the same day in the same guide tube location, the electrode was required to be at least 500 microns from the first site.

3.2.3 - Behavioral task and experimental parameters

At the start of each day, monkeys were placed in a customized primate chair (designed and built in-house) designed to provide either complete restraint or complete motility of the head. Both monkeys wore a customized primate vest (Lomir Biomedical) that could be fastened to the chair and was successful at restricting trunk rotation (maximum of 10° in any direction) without restraining the head or neck. The monkeys were then placed in the middle of a 3 ft³ coil system (CNC engineering) which resided in a dark and sound-attenuated room. An array of tri-colored equiluminant LEDs (red, green and orange) were placed horizontally 24 inches in front of the monkeys. All aspects of the experiment were controlled at 1000 Hz by a customized real-time

LabVIEW programs which interfaced with hardware through a PXI controller (National Instruments).

Monkeys were trained on a gap-saccade task that required them to look from a central fixation point (FP) to a peripheral stimulus (S) to obtain a liquid reward. Monkeys were initially trained on this task with the head-restrained. When head-unrestrained, the monkey received a liquid reward via a sipper tube that moved with head. At the start of the day, we used non-central FP positions to identify valid SEF sites, based on whether stimulation evoked a saccade. As described elsewhere (Schlag and Schlag-Rey 1987), the probability of evoked saccades increased for FP positions ipsilateral to the side of stimulation. Once a valid SEF site was identified we ran the gap-saccade task described below with only a central FP, this was done to control for variation in background neck EMG activity with the eye-in-head position (Corneil et al. 2002a; Andre-Deshays et al. 1988).

After an SEF site was identified, control and stimulation trials were intermixed in equal probabilities. Both trial types were initiated with the removal of a diffuse background light that prevented dark adaptation. A central red FP was then provided directly in front of the monkey. The monkeys had to acquire the FP within 1000 ms and hold gaze within a computer controlled window (5°) between 750-1250 ms, otherwise the trial would be terminated. The FP was then removed. On stimulation trials, stimulation started 200 ms into the gap period and lasted for either 150-200 ms (head-restrained) or 200-300 ms (head-unrestrained). Once stimulation ended, a S was presented at one of eight different radial eccentricities. The eccentricity of the Ss was set at either 10° or 15° when the head was restrained or set at 15° or 20° when the head was unrestrained. On

control trials, the duration of the gap interval matched that during stimulation trials; therefore, it was set at either 350-400 ms (head-restrained) or 450-500 ms (head-unrestrained). The monkeys had to maintain gaze in the fixation window during the gap period on control trials, but this constraint was removed after the onset of stimulation to account for the possibility of evoked saccades. The monkeys had 1000 ms to look to the target within a computer controlled window on stimulation trials (5 radial degrees). All variables (i.e. fixation duration, trial type, target location) during this task were presented an equal number of times within a block of ~60 trials in a pseudo-random order. Note that the use of eight potential targets distributed radially around the central FP decreases the likelihood that the monkeys would prepare a specific saccade during the gap period (Basso and Wurtz 1997).

3.2.4 - Data collection and analysis

The protocol for acquiring the EMG signals has been described elsewhere (Elsley et al. 2007). Briefly, the processing of the EMG signal commenced at a head stage that was plugged directly into the EMG connector that was embedded in the acrylic implant. The headstage (Plexon) performed differential amplification of the EMG signals (20x gain) and filtering (bandwidth, 20 Hz to 17 kHz). A flexible ribbon cable linked the headstage to the Plexon preamplifier, which contained a signal processing board customized for EMG recordings (50x gain; bandwidth, 100 Hz to 4 kHz). All analog signals were digitized at 10 kHz. Offline, EMG signals were notch filtered to remove 60-Hz noise, then rectified and integrated into 1 ms bins, using a rationale described

previously (Bak and Loeb 1979). These steps attenuated the digitized peak-to-peak amplitudes by a factor of ~ 3 .

Horizontal and vertical head movements were measured via a second coil that was secured in the frontal plane to the head post. Horizontal gaze (eye-in-space) and head movements were filtered, amplified and digitized at a rate of 10 kHz onto a MAP box (Plexon). Offline, these signals were downsampled by a factor of 10 to 1 kHz. The monkeys were monitored throughout the experiment by investigators by infrared cameras that were positioned outside the monkey's line of sight.

Gaze, head and EMG signals were analyzed offline using customized MATLAB (The Mathworks) programs. A graphical user interface (GUI) was designed to automatically detect the beginning and end of gaze shifts and head movements using velocity thresholds of 30 °/s (gaze) or 10 °/s (head) and display the data. These marks could be changed by an analyst who could also reject trials for other reasons (e.g. excessive EMG activity). Anticipatory movements (< 60 ms from T onset) or movements that began > 600 ms after stimulus onset were automatically discarded. Customized MATLAB programs then extracted characteristics of behavioral performance and analyzed EMG activity.

3.3 - RESULTS

Stimulation was delivered throughout a large sampling of the dorso-medial frontal cortex in two monkeys (Fig 3-2 A). Saccades were reliably evoked from non-central FP locations from a total of 216 unique sites (86 in monkey S and 130 in monkey Z) with standard stimulation parameters (300 Hz, 100 μ A, duration 150-300 ms) and hence met

Figure 3-2. A: depiction of the grid locations in both animals. Each circle represents a grid location, with filled circles representing locations where an SEF site was identified. Each grid location could contain multiple sites which were visited on separate days. Each circle is sub-divided in the enlargement into four quadrants representing the size of the gaze shift from center. Upper left quadrant = number of sites with evoked gaze shifts $< 10^\circ$, Upper right quadrant = number of evoked gaze shifts between $10\text{-}20^\circ$, lower left quadrant = number of evoked gaze shifts $> 20^\circ$ and lower right quadrant = number of EMG responses with no gaze shift. B: vector plots depicting the range of gaze shifts evoked from center from all stimulation sites in both monkeys. All vectors originate from the center fixation point with the majority of gaze shifts being evoked contralateral to stimulation. Data are divided into evoked vectors with the head-restrained (left plot) or with the head-unrestrained (right plot); the data obtained from the left-SEF of monkey S was flipped across the vertical meridian for this plot. Here leftward gaze shifts are directed contralateral to stimulation in these plots.

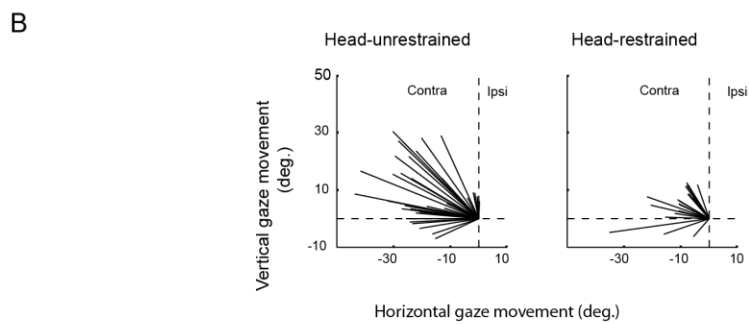
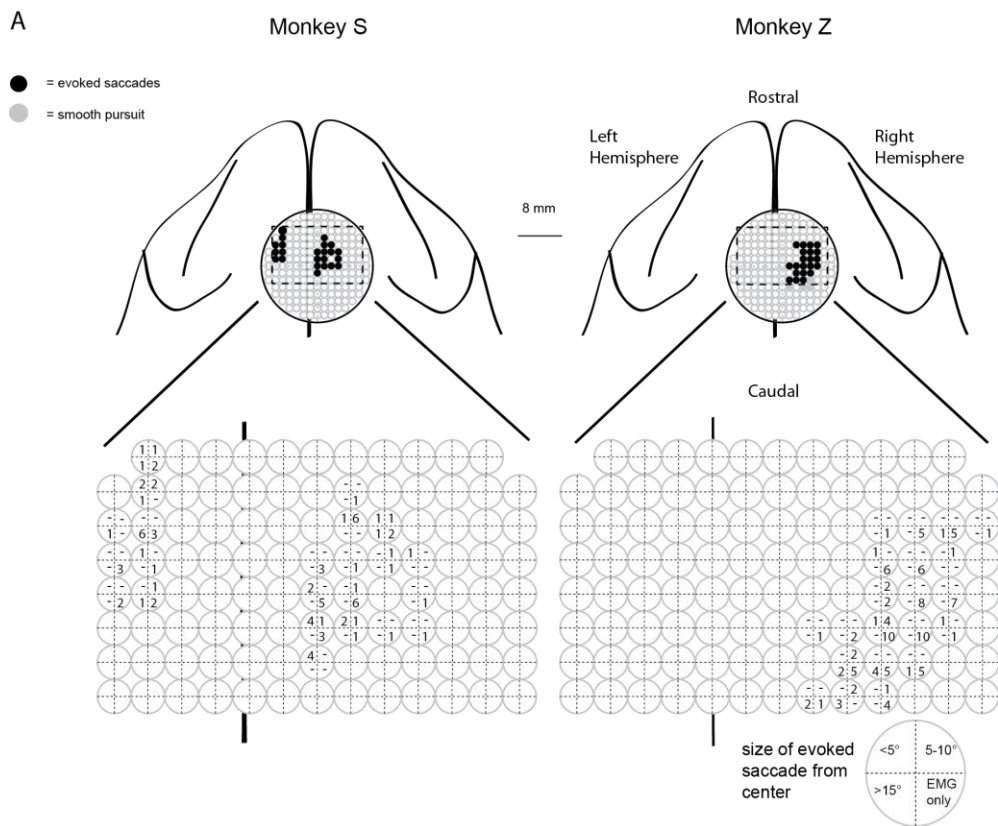

our inclusion criteria. 115 of these sites were examined only with the head-restrained, 50 of these sites were examined only in the head-unrestrained condition and 25 of the sites were studied in both the head-restrained and head-unrestrained conditions. Longer duration stimulation (two sites were studied at 300 ms, 48 sites were studied at 200 ms) was applied during some stimulation sessions in the head-unrestrained condition only.

The anatomical distribution of SEF sites were consistent with previous studies, generally distributed between 2-5 mm from midline and between the caudal end of the arcuate sulcus and the rostral end of the superior arm of the arcuate sulcus (Schlag and Schlag-Rey 1987; Schall 1991; Chen and Walton 2005). Almost all (99%) of the evoked movements had a contralateral component. Furthermore, we encountered a few caudal sites in monkey Z where stimulation evoked smooth pursuit eye movements, consistent with previous reports (Missal and Heinen 2001).

3.3.1 - Timing and metrics of evoked movements

Our characterization of evoked movements and accompanying EMG responses was always obtained when the task was run with a central FP. SEF stimulation reliably evoked saccades from center in 55 sites. When stimulation did evoke gaze shifts, the evoked gaze shifts spanned a large horizontal and vertical range (Fig. 3-2 B). In the head restrained condition, all evoked movements were directed to the contralateral side of stimulation. On one occasion in the head-unrestrained condition, the evoked gaze shift had an ipsilateral horizontal component; however, this movement was quite small ($<1^\circ$). Although stimulation was applied to both the right and the left SEF in monkey S, we have organized our data so that movement direction is referenced contralateral or

ipsilateral to stimulation. We recorded a large range of contralateral gaze shift vectors from the SEF with the head both restrained and unrestrained. Gaze shifts evoked with the head-restrained ranged from 5-35° (left plot, Fig 3-2 B), and gaze shifts evoked with the head-unrestrained range from 2-45° (right plot, Fig. 3-2 B). Throughout our sample, the mean latency of gaze shift onset relative to stimulation was 92.4 ± 32.9 ms (range: 40 - 164 ms). When the head was unrestrained, the eye-in-head, head-in-space and eye-in-space positions were closely aligned in the horizontal plane (mean horizontal eye-in-head position = $1.4 \pm 7.0^\circ$, mean horizontal eye-in-space = $0.25 \pm 4.5^\circ$), and the head was tilted upward slightly in the vertical plane (mean vertical eye-in-head position = $-13.3 \pm 5.1^\circ$, mean vertical eye-in-space = $-0.4 \pm 2.5^\circ$). From our head-unrestrained sample, the total amplitude of evoked head movements was $12.6 \pm 6.7^\circ$ along the horizontal plane and $2.2 \pm 1.9^\circ$ along the vertical plane. The head contribution of the gaze shift was $3.5 \pm 3^\circ$ of the horizontal component and $0.7 \pm 0.8^\circ$ of the vertical component. The mean of the evoked head movement onset was 72.5 ± 27.4 ms (range = 37.8-165.8 ms).

We observed a number of relationships between the timing and metrics of head-unrestrained gaze shifts. First, we observed a positive correlation between evoked gaze shift magnitude and the amount the head contributes to the gaze shift (Fig. 3-3 A). Therefore, larger head contributions accompanied larger gaze shifts. Across our sample, the head started to contribute for evoked gaze shifts greater than 10° in amplitude. Second, the proportional head contribution to the gaze shift was larger the earlier the head began to move relative to gaze onset. This was calculated by plotting the proportional head contribution to the gaze shift as a function of gaze-head lead time (Fig. 3-3 B, derived as Head RT – Gaze RT; therefore, negative values indicate observations

Figure 3-3. A-B: metrics of eye-head gaze shifts evoked with the head-unrestrained. A: plot of head contribution (amount the head moves during a gaze shift) as a function of evoked gaze shift magnitude. Each square is taken from a different stimulation site and represents the mean head contribution and mean gaze shift magnitude \pm standard deviation. We observed a positive correlation between these two measures ($R = 0.86$, $P < 0.001$). B: head contribution as a percentage of the magnitude of the evoked gaze shift plotted against the gaze-head lead time (Head RT – Gaze RT, negative values represent sites where head movement onset began prior to gaze onset). Each square is taken from a different stimulation site. We observed a negative relationship between these two variables ($R = -0.76$, $P < 0.001$). C-D: represent main sequence functions (Head amplitude plotted as a function of head velocity) for both monkeys (C: monkey S, D: monkey Z). Each point represents data averaged across all head movements averaged with 5° bins. Dashed lines denote head movements evoked by SEF stimulation, solid lines represent volitional head movements made during control trials (shifted forward by 2°). X's placed on the x-axis represent significant differences between evoked and volitional movements (paired t-test, $P < 0.05$).

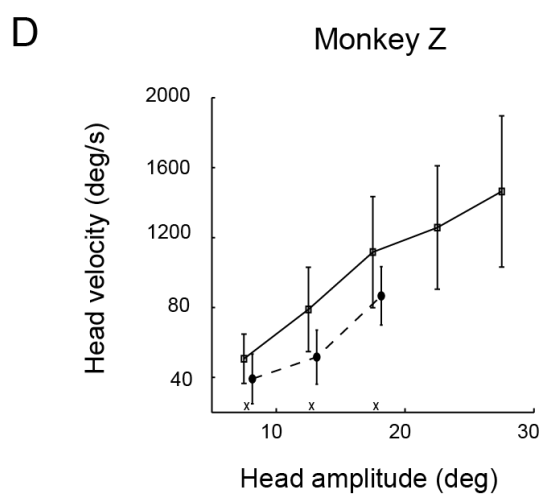
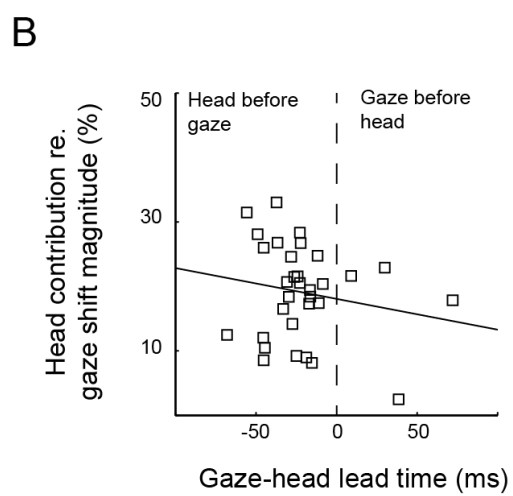
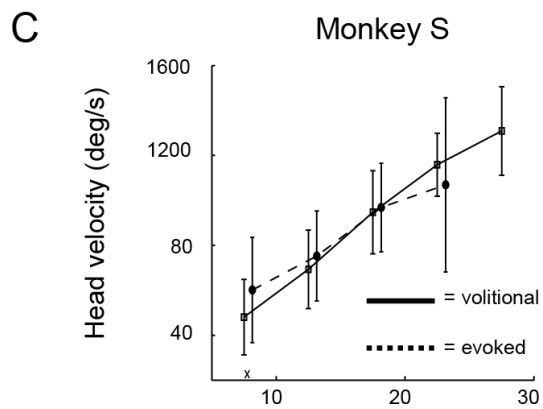
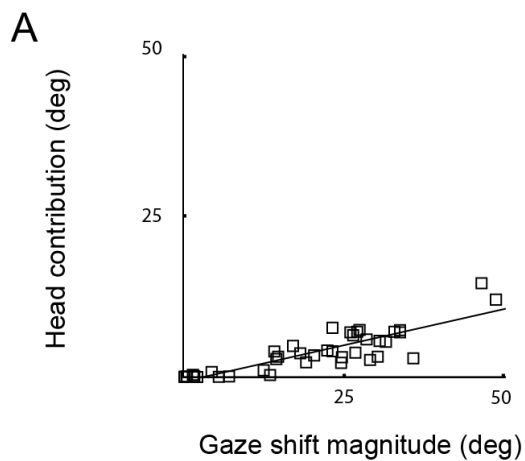

where Gaze RT was greater than Head RT). This analysis emphasizes that the onset of head motion usually preceded the gaze shift; on such trials gaze remained stable due to counter-rotation of the eye within the head. Finally, we also compared the velocity-amplitude main sequence relationships of head movements evoked by SEF stimulation to those accompanying volitional eye-head gaze shifts. For monkey S, the main sequence relationships for volitional and evoked movements overlapped. For monkey Z, the main sequence relationships for evoked head movements lay significantly below that for volitional movements, this result was similar previous reports (Elsley et al. 2007).

Overall the kinematics and timing of eye-head gaze shifts evoked by SEF stimulation resembles previous reports (Chen and Walton 2005; Martinez-Trujillo et al. 2003) despite considerable differences in the behavioral paradigm and stimulation protocol. Having established this, we now turn to the analysis of evoked neck muscle responses.

3.3.2 - Analysis of neck muscle EMG activity evoked by SEF stimulation

Here, we quantify neck EMG responses evoked by SEF stimulation and analyze its relationships with aspects of any evoked gaze shifts or head movements. Stimulation of the SEF results in substantial changes in neck muscle activity. The evoked responses consisted of the recruitment of a contralateral head turning synergy relative to the side of stimulation, and a more variable recruitment of an upward or downward head pitching strategy. Given that the recruitment of the turning synergy was far more consistent, we will primarily discuss the horizontal recruitment of the head turning synergy in the

ensuing analysis and elaborate on the more variable vertical synergies at the end of the results section.

Representative examples of neck muscle responses evoked by SEF stimulation are shown in Fig. 3-4. These examples demonstrate activity associated with relatively small ($< 10^\circ$, Fig 3-4 A) and relatively large ($> 20^\circ$, Fig. 3-4 B) evoked gaze shifts. Both of these examples were recorded from monkey S in the head-restrained condition. SEF stimulation of both exemplar sites evoked facilitation in the agonist neck muscles contralateral to the side of stimulation (Contra-OCI, RCM and SP, see Fig 3-1 A for schematic drawings of these muscles). Such facilitation began shortly after stimulation (20-40 ms), peaked within the first 75 ms following stimulation onset, and then persisted until the end of stimulation. After cessation of stimulation, EMG activity quickly returned to baseline levels of activity prior to stimulation. These data are also ordered by increasing onset latency of the evoked gaze shift (denoted by white squares) demonstrating that the evoked neck muscle responses preceded evoked gaze shifts and persisted on trials without an accompanying gaze shift. For this example, no inhibition of activity was observed (ipsi-OCI and -SP) as there was no background activity. When movements were evoked with non-central FPs and baseline EMG activity was larger, inhibition was observed on the antagonist neck muscles.

Figure 3-4 C/D show data from the second monkey (monkey Z) when the head was unrestrained. These representative sites are organized as described in Fig. 3-4 A/B and have been selected to show evoked neck muscle responses associated with similarly sized gaze vectors. Although the absolute magnitudes of EMG recruitment are not directly comparable, we can make some general comparisons. First, a similar facilitation

Figure 3-4. A-B: Exemplar data showing evoked movements and neck muscle activity with either the head-restrained (monkey S; A, B) or –unrestrained (monkey Z; C, D). Evoked gaze shifts were either intermediate (A) or large (B) in magnitude. Horizontal (Gh, L = left) and vertical (Gv, U = up) average amplitudes of evoked gaze shifts are provided at the top of each plot. Stimulation was passed for 150 ms in these examples (vertical dashed white or black lines). Within each column, the top two traces show the horizontal and vertical gaze position traces (thin black lines). EMG activity is shown for five muscles: three contralateral agonist muscles and two ipsilateral antagonist muscles. All muscles shown here are horizontal head turners. For each muscle in each column, color plots show EMG activity aligned to stimulation onset. Each stacked row represents data from a single trial organized by gaze shift onset (white squares superimposed on the color plots, ~30 stimulation trials in each plot. Gaze shifts were not evoked on trials without white squares). Black contour lines below each plot show mean evoked EMG activity. Scale bars to the right of EMG traces in column B apply to the data in column A as well. C-D: Gaze and head movements evoked by SEF stimulation collected with the head-unrestrained. Circular white dots superimposed on the color plots represent head movement onset. Data is organized in the same format as A and B with the exception that horizontal (Hh) and vertical (Hv) head traces are shown (thin black lines).

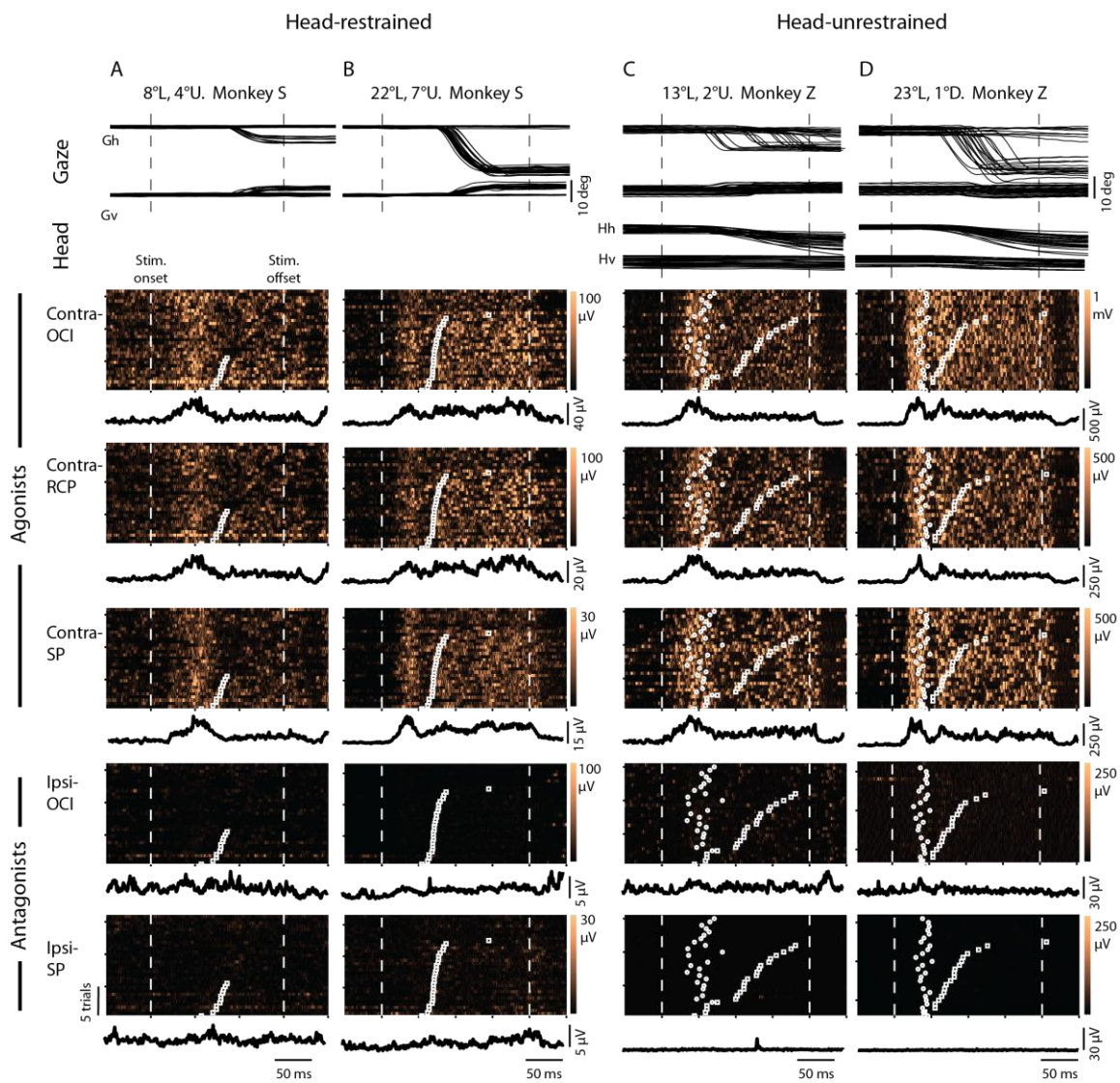

on the agonist muscles is apparent ~20 ms after stimulation onset when the head is unrestrained regardless of the size or presence of the ensuing gaze shift. In addition, there does not appear to be any inhibition on the muscles ipsilateral to stimulation, again due to negligible activity prior to stimulation onset. SEF stimulation frequently elicited head movements as well as gaze shifts. In Fig. 3-4 C/D, head movements typically started ~40-75 ms after stimulation onset (Fig 3-4 C/D, white circles), usually well before the gaze shift. Similar to previous studies (Chen and Walton 2005), we occasionally observed trials consisting of evoked head movements without an accompanying gaze shift (Fig 3-4 C/D, trials with circles but no squares); the eyes counter-rotated in the head during such head-only movements to maintain gaze stability.

3.3.3 - Influence of head restraint on evoked neck muscle responses

Before proceeding with description of our exemplar stimulation sites, we first examine the influence of head restraint on evoked neck muscle responses. As previously mentioned, we obtained 26 sites where data was collected in both the head-restrained and head-unrestrained condition (data was collected with the head-restrained first). We compared both the peak magnitude of evoked EMG activity and the facilitation latency for contralateral head turning muscles across this subset of sites. For all three horizontal head turning muscles, there was no significant differences for either peak magnitude or facilitation latency across head restraint (Fig. 3-5 A, Magnitude: paired t-test, $P = 0.1$, 0.07 , 0.18 for OCI, RCM and SP respectively. Latency: paired t-test, $P = 0.8$, 0.14 , 0.84 for OCI, RCM and SP respectively).

Figure 3-5. Comparison of evoked EMG activity in the head-restrained vs –unrestrained condition. A-B: comparison of EMG response parameters on the contralateral muscles, taken from the subset of sites studied in both the head-restrained and –unrestrained condition. Each point denotes mean value [either of peak evoked magnitude (A) or facilitation latency (B)] obtained with the head-restrained plotted against the mean value with the head-unrestrained for a single stimulation site. Filled squares in A represent magnitudes that were significantly different across condition (paired t-test, $P < 0.05$). Statistical testing in B was not possible within a stimulation site as response latencies were derived from mean EMG waveforms and therefore do not have a variance. Diagonal line denotes the line of unity. Peak evoked magnitudes (A) tended to be above the line of unity but not statistically different (paired t-test; OCI $P = 0.1$, RCM $P = 0.07$, SP $P = 0.18$). Facilitation latencies also did not differ significantly across head restraint (paired t-test; OCI $P = 0.8$, RCM $P = 0.14$, SP $P = 0.83$).

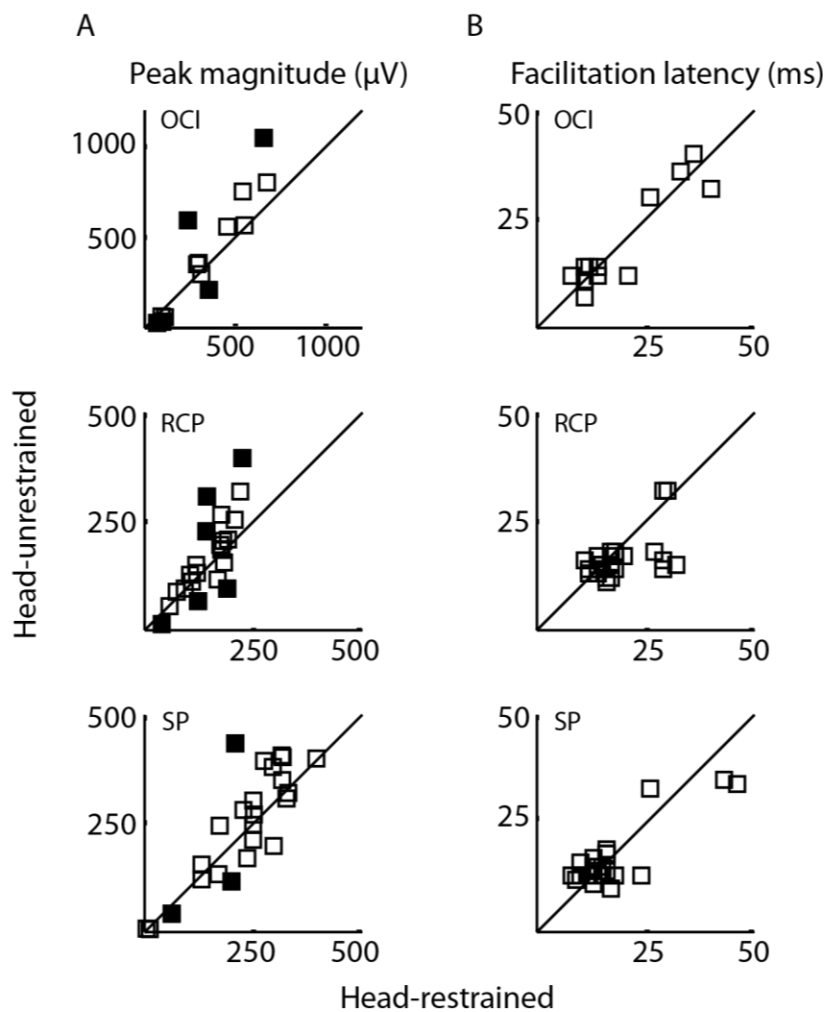

3.3.4 - *Quantification of evoked neck EMG responses from the SEF*

For the ensuing population analyses, we pooled the head-restrained and head-unrestrained data such that every data point represents a unique stimulation site. The data were combined from the 115 sites collected with the head-restrained, the 50 sites collected head-unrestrained and the 26 sites collected in both conditions (from these 26 sites, we only use data from the head-unrestrained condition). Across the 190 unique stimulation sites, EMG responses were evoked on the majority of trials and this evoked activity almost always preceded the ensuing gaze shift. We also observed robust EMG activity even on trials without any accompanying gaze shift and/or head movement.

As with our exemplar data, SEF stimulation consistently evoked facilitation of the neck muscles contralateral to stimulation (Fig. 3-6 A-C). Such contralateral muscle facilitation was never accompanied by any co-contraction of the ipsilateral turning muscles. Instead SEF stimulation evoked a concomitant suppression of ipsilateral muscle activity when background activity was sufficient. Thus, the synergy evoked by SEF stimulation resembled the head turning synergy evoked by stimulation of the FEF (Elsley et al. 2007) and SC (Corneil et al. 2002b), and that seen during volitional head turns (Corneil et al. 2001). We constructed averages of evoked EMG activity by taking the mean stimulation-aligned waveform across all stimulation trials. We observed a significant evoked neck EMG response on at least one neck muscle in 95% (182/191) of our stimulation sites [a significant facilitation of contra-OCI, -RCM and -SP was seen in 72% (137/191), 77% (148/191) and 85% (163/191) respectively, of all stimulation sites. Facilitation was considered significant when activity reached two standard deviations

Figure 3-6. Correlations between parameters of evoked responses on contralateral muscles (A-C: facilitation latencies; D-F: normalized peak evoked magnitude) plotted against the horizontal component to the evoked gaze shift. Evoked EMG responses tended to begin earlier and have larger peak magnitudes when associated with larger gaze shifts. Peak evoked magnitude data were normalized to maximum evoked response for each monkey. Gh = horizontal gaze movement. Each square shows data taken from a unique stimulation site. All regressions were statistically significant (A-C; contra-OCI: $r = -0.56$, $P < 0.001$, $n = 44$; contra-RCM: $r = -0.44$, $P < 0.001$, $n = 55$; contra-SP: $r = -0.56$, $P < 0.001$, $n = 53$. D-F; contra-OCI: $r = 0.52$, $P < 0.001$, $n = 44$; contra-RCM: $r = 0.33$, $P < 0.05$, $n = 55$; contra-SP: $r = 0.65$, $P < 0.001$, $n = 52$).

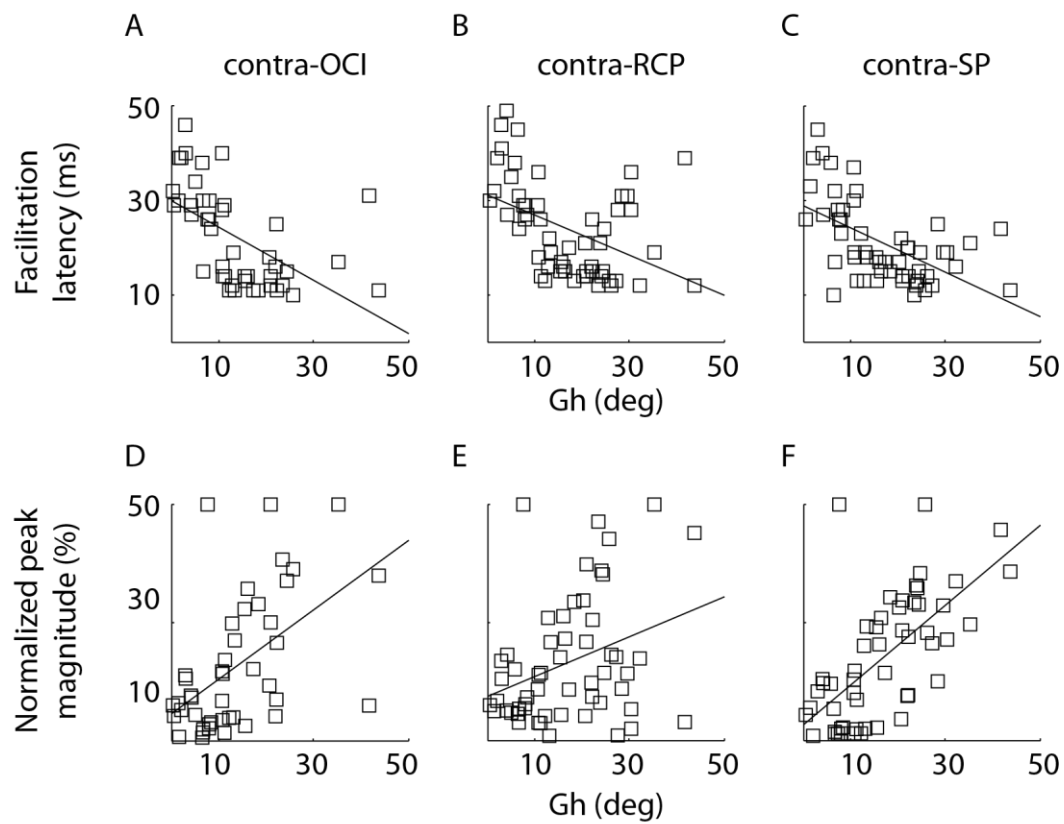

above baseline activity. The majority of facilitation latencies were <70 ms [28.4 ± 34.9 ms (median = 19.5 ms) for contra-OCI, 34.7 ± 39.6 ms (median = 22 ms) for contra-RCM and 29.13 ± 37.3 ms (median = 19 ms) for contra-SP]. When present, the onset of ipsilateral muscle inhibition was the same as the facilitation latencies on the contralateral muscles.

It is important to stress that significant evoked neck muscle responses accompanied small gaze shifts $<5^\circ$ in magnitude, even if this response was relatively weak and slow in developing. Evoked neck EMG responses tended to begin sooner and reach larger magnitudes when evoked from sites associated with larger gaze shifts. The relationship between evoked gaze magnitude and facilitation latencies is shown for all three muscles (Fig. 3-6 A-C). Stronger neck muscle recruitment also accompanied progressively larger gaze shifts, which presumably relates to the increasing head contribution relationships between the size of the evoked gaze vector and the onset of EMG activity, with shorter EMG onsets being associated with larger gaze shifts. In addition, we plotted the relationship between normalized peak magnitudes of EMG activity against the evoked gaze vector (Fig 3-6 D-F). Larger peak magnitudes are associated with increasingly larger evoked gaze vectors.

3.3.5 - Timing of evoked neck EMG responses relative to gaze onset

Here, we examine the timing of evoked neck EMG responses relative to evoked gaze shifts. A comparison of the facilitation latencies of the mean EMG responses on the contralateral facilitation latency of EMG onset was significantly shorter than mean gaze onset (Fig. 3-7, paired t-test, $P < 0.001$ for all muscles)]. The mean EMG facilitation

latency led gaze onset for contra-OCI, -RCM and -SP by 65 ms, 71.5 ms and 75.5 ms respectively.

A shortcoming of the previous analysis is that it extracts EMG facilitation latency after averaging all stimulation trials, which is first determined on a trial-by-trial basis and then averaged. This could potentially overstate the difference between these response latencies as EMG facilitation latency could be excessively influenced by trials that have a rapid onset. To address this problem, we performed a second analysis where we determined the facilitation latency of EMG onset on a trial-by-trial basis. We identified the onset of evoked EMG responses on a trial-by-trial basis using an approach described previously (Elsley 2007, see Fig 3-8A). Briefly, on each trial we constructed a cumulative EMG response across multiple muscles by adding the normalized increase in EMG activity from agonist muscles with the inverted normalized suppression of antagonist muscles (if present). The onset of an evoked response was determined when the level of this cumulative EMG response after activity exceeded 2 standard deviations from the average EMG activity of the 50 ms before stimulation.

The results for a single stimulation site (same site as shown in Figure 3-4 B) are shown in Fig. 3-8B, plotting the facilitation latency of EMG onset as a function of gaze shift onset on a trial-by-trial basis (each square represents data from a single trial; x's represent trials with EMG responses without gaze shifts). From this individual site, it is apparent that EMG onset preceded gaze onset on almost every individual trial by ~30 ms.

We extended this analysis across our sample, comparing the relative onset of EMG activity with gaze onset in two different ways. First, for each stimulation site we

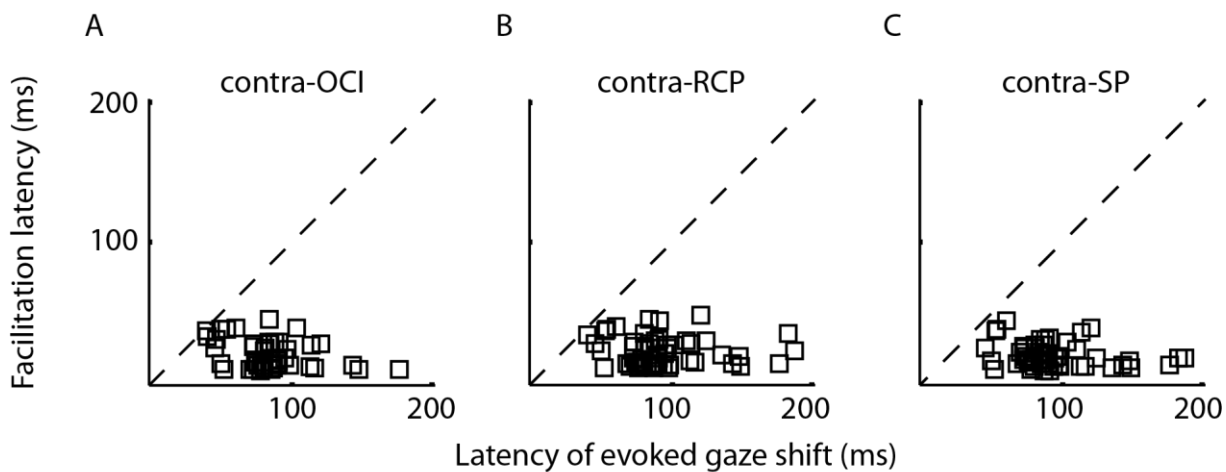
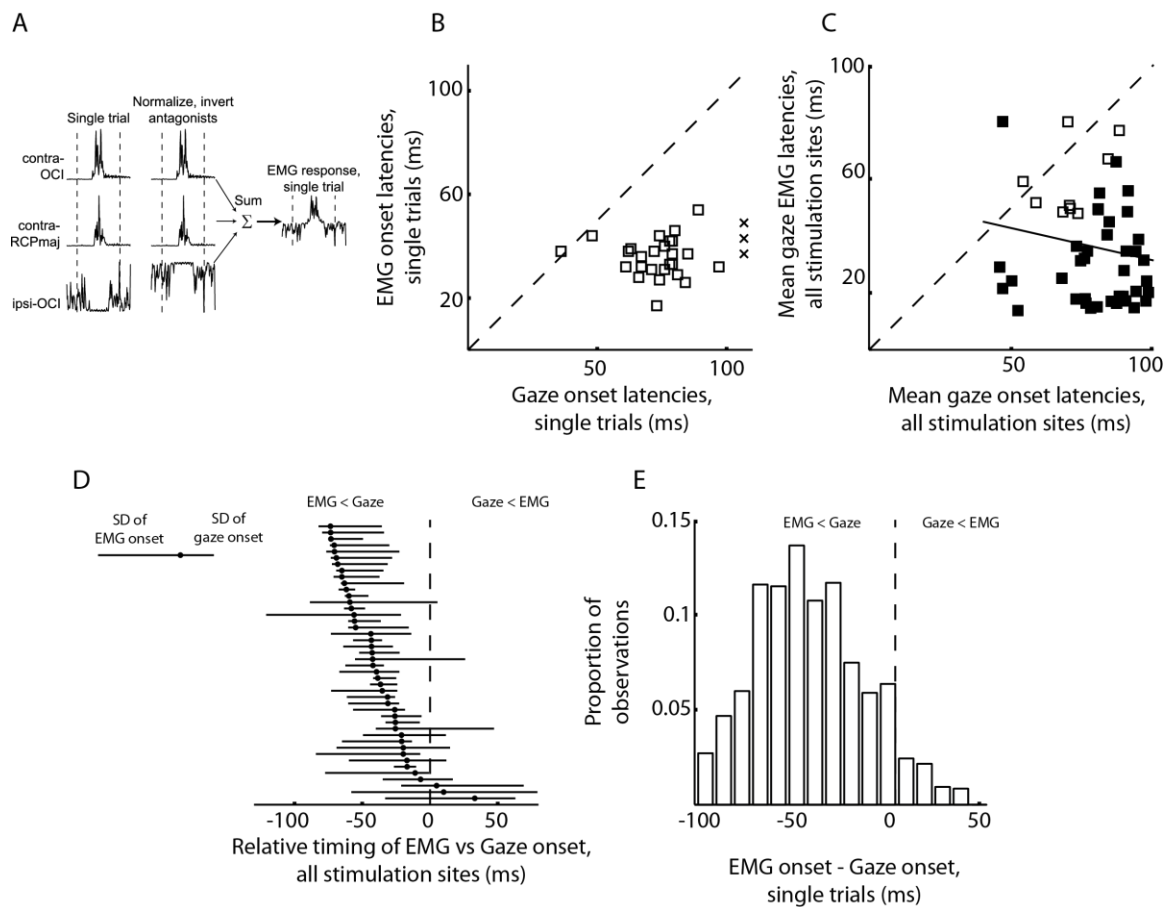

Figure 3-7. Plot of facilitation latency as a function of the latency of evoked gaze shift for contralateral head turner muscles. Each data point represents data taken from a unique stimulation site. All data clustered below the line of unity (dashed line) showing that the facilitation latencies were shorter than gaze shift reaction latencies (paired t-test, $P < 0.001$ for all three muscles).

Figure 3-8. A graphical depiction of how cumulative EMG response was derived on a trial-by-trial basis. EMG data from muscles that showed a significant response (depicted as contra-OCI, contra RCM and ipsi-OCI) were first normalized to the maximum value recorded in a given experimental session. EMG traces from the antagonist muscles were inverted and summed with EMG traces from all agonist muscles, resulting in a single cumulative EMG trace expressing change in EMG activity across multiple muscles on a single trial. B: trial-by-trial plot of the cumulative EMG onset latencies plotted as a function of the evoked gaze onset latencies, taken from the same data as shown in Fig. 3-4B. Each square shows data from a single trial and each 'x' shows data from trials in which a gaze shift was not evoked (plotted on the far right of graph). This data clusters below the line of unity (dashed diagonal line), showing that EMG onset latencies were shorter than gaze shift onset latencies [here, by 37.3 ± 14.7 ms (paired t-test, $P < 0.001$)]. C: plot of mean EMG latency against mean gaze onset latency with both measures first determined on a trial-by-trial basis. Each square shows data taken from a single stimulation site with filled squares denoting significant differences between mean onset EMG and mean onset gaze latencies (2-way t-test, $P < 0.05$). Clustering of data below the line of unity (dashed line) was significant ($P < 0.001$) but these values were not correlated. D: plot of the relative timing of EMG onset versus gaze onset with variance measures across all stimulation sites. Each point represents data taken from a single stimulation site, plotting relative timing of the EMG response vs. the gaze response (data was organized based on decreasing differences between these two measures). Positive values denote sites where gaze onset began before EMG onset. Horizontal error bars to the *left* or *right* of the black circles represent the SD of the EMG response or the gaze



shift response, respectively, for each stimulation site. E: frequency histogram of the difference between EMG onset and gaze shift onset, determined on a trial-by-trial basis across all stimulation sites. Positive values imply that the gaze shift response started before EMG onset. This distribution (-38.8 ± 31.3 ms, $n = 1070$) is significantly below 0 (t-test, $P < 0.001$).

plotted the mean EMG onset latencies against the mean gaze onset latencies, both derived first on a trial-by-trial basis muscles to the mean onset latency of the evoked gaze shift (see Fig 3-7) revealed that the mean onset of EMG activity is shorter than the mean onset of gaze [for all muscles, the mean (Fig. 3-8 C)]. To be included in this analysis, a minimum of 10 gaze shifts and 10 EMG responses had to be observed with a single stimulation site. The mean EMG onset latencies occurred before gaze onset in 94% (44/47) sites meeting this criteria, with an average difference of 42.4 ± 25.8 ms. Further, since trial-by-trial onsets for both measures can be derived, we can also measure the variability of each response. Fig. 3-8 D represents the relative timing of EMG and gaze onset (black circles), as well as the standard deviation of each measure. This plot again emphasizes that on a trial-by-trial basis, EMG responses occurred prior to gaze shift onset on the majority of trials.

Finally, we compared the relative timing of the EMG and gaze shift onset across all stimulation trials where both a gaze shift and a neck muscle response were evoked (see Fig. 3-8 E, pooling across both monkeys and all stimulation trials, $n = 1070$). A histogram representing the lead time between EMG onset and gaze shift onset (EMG onset – Gaze shift onset) shows that the EMG response preceded the gaze shift by 38.8 ± 31.2 ms with negative values (where EMG onset preceded gaze onset) occurring on 87% of all trials. Overall, these results demonstrate conclusively that when stimulation is applied to the SEF, neck EMG responses almost always preceded the evoked gaze shift.

3.3.6 - Timing and magnitude of evoked neck EMG responses relative to the evoked head movement

Deriving latencies of EMG onset on a trial-by-trial basis permits us to compare these responses to the parameters of the evoked head movement as well. Fig. 3-9 shows a number of relationships between evoked EMG activity and the ensuing head movement, determined on a trial-by-trial basis. First, we compared mean EMG onset latencies against the mean head onset latencies across all stimulation sites (Fig 3-9 A), and found that the EMG responses lead head movements on almost every site that had both EMG and head movement responses. On average the EMG response led head movement onset by ~42 ms. Fig 3-9 B plots the timing of the EMG response relative to head onset (black circles). This figure is constructed in the same way as figure 3-8 D, but with standard deviation for head movement onset to the right of the circles. Again, EMG responses led head movements at almost all stimulation sites. We also constructed a histogram comprised of every single trial that had both an evoked EMG response and evoked head movement (Fig. 3-9 C). We found that the EMG response occurred prior to head movement onset by 37.7 ± 29.6 ms, with values less than -10 (i.e. EMG preceding head movement onset by greater than 10 ms) occurring on 94% of trials. We also compared the magnitude of EMG recruitment to the kinematics of evoked head movements. We constructed the normalized integral of the composite EMG response on a trial-by-trial basis (i.e. identifying the area under the composite curve shown in Fig 3-8 A for each trial) and plotted these values against head amplitude (Fig 3-9 D) and head

Figure 3-9. Comparison of parameters of evoked neck EMG response to the ensuing head movement. A: plot of mean EMG latency (determined on a trial-by-trial basis within a given stimulation site) as a function of mean onset of head movement. Each square shows data taken from a unique stimulation site, with filled symbols showing EMG responses that were significant different from mean head movement onset (2-way t-test, $P < 0.05$). Data clustering below the line of unity was significant (paired t-test, $P < 0.001$) suggesting that EMG lead head onset by 42 ± 28.4 ms. The regression also reached significance ($r = 0.63$, $P < 0.001$, $n = 45$). B: plot of the relative timing of the EMG response vs. head movement onset, with associated variance measures. Plot is designed in the same format as Fig. 3-8 D with the exception of error bars to the right of the black circles represents standard deviation of head movement onset. C: frequency histogram of the difference between EMG onset and head movement onset, determined on a trial-by-trial basis. Same format as Fig. 3-8 E. This distribution (-37.7 ± 29.6 ms, median = -33 ms) is significantly distributed below zero (t-test vs. 0, $P < 0.001$). D-E: trial-by-trial correlations of either overall head movement amplitude (D) or peak head velocity (E) to the integral of the composite EMG response. This integral was calculated by taking the area under the EMG response curve (shown in Fig. 3-8 A) for the duration of stimulation and subsequently normalized to the largest integral observed for each monkey. Regressions for both graphs were significant (D: Pearson's $r = 0.54$, $P < 0.001$, $n = 942$. E: Pearson's $r = 0.55$, $P < 0.001$, $n = 942$).

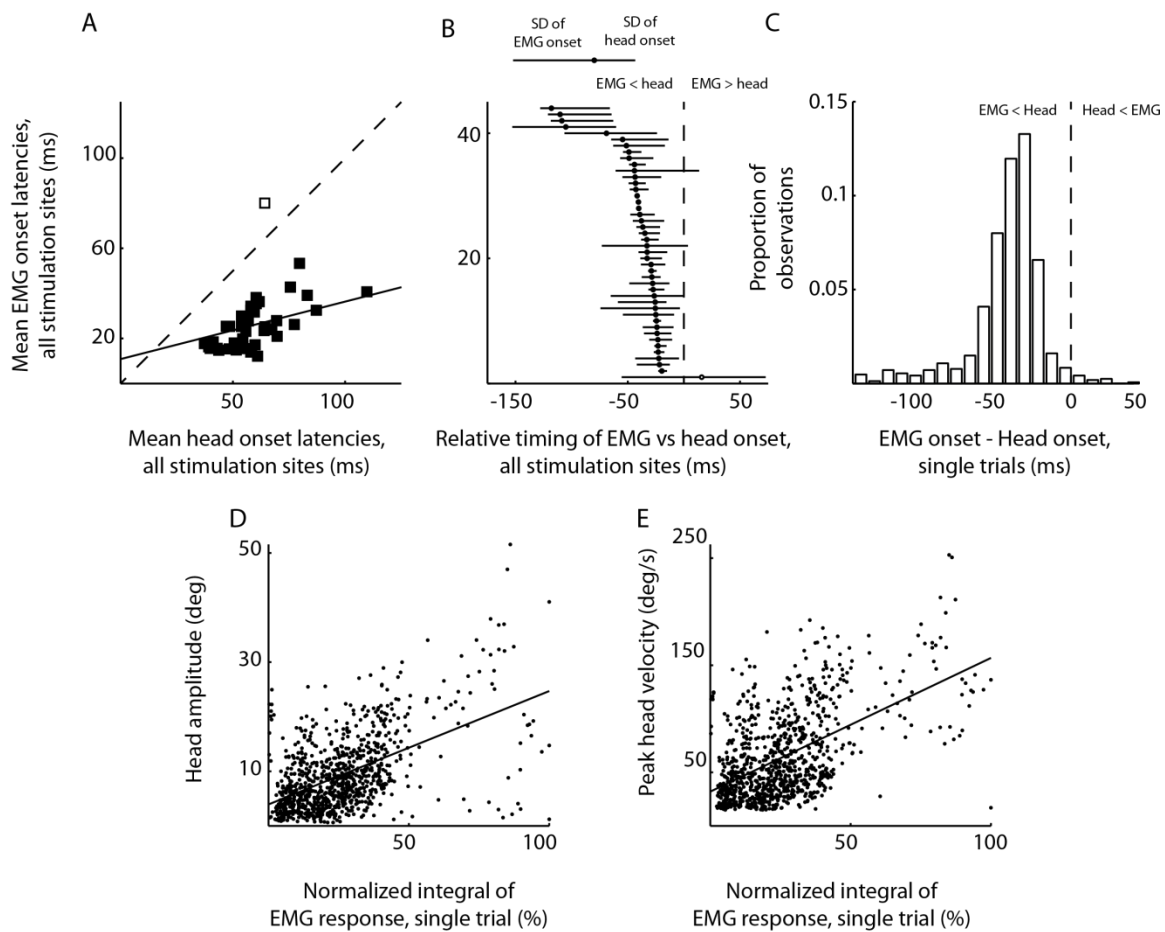

velocity (Fig. 3-9 E). The EMG response was a strong predictor of both head movement amplitude and head movement velocity ($r = 0.54$, $P < 0.001$ and $r = 0.55$, $P < 0.001$ respectively), consistent with the evoked neck EMG response driving the subsequent evoked head movement.

3.3.7 - EMG activity associated with no gaze movements

As mentioned previously, we applied a fixed current of 100 μA at all of our stimulation trials. Recall that our criteria for identifying a valid SEF site required that stimulation consistently evoke a gaze shift from any initial gaze position, but that our analysis of EMG activity was only derived when initial gaze position was straight ahead. Because of this, we frequently observed trials where SEF stimulation failed to evoke a gaze shift. In fact, across all trials, SEF stimulation evoked a saccade only 35.4% of the time. As shown in fig. 3-4, robust neck EMG responses were observed on trials without gaze shifts.

To quantify this observation, we began by comparing EMG responses on trials with gaze shifts against trials with no gaze shifts. For this analysis, stimulation at a given site had to evoke a minimum of five trials either with or without an accompanying gaze shift. The results of this analysis are shown in Figure 3-10, comparing both onset latency of the EMG response (Figure 3-10 A) and the normalized integral of the composite EMG response (Figure 3-10 B). This quantitative analysis of EMG response reveals that a significant neck EMG response was always observed on no-gaze trials (if no EMG response was recorded on no-gaze trials, all points would fall along the x-axis). Second,

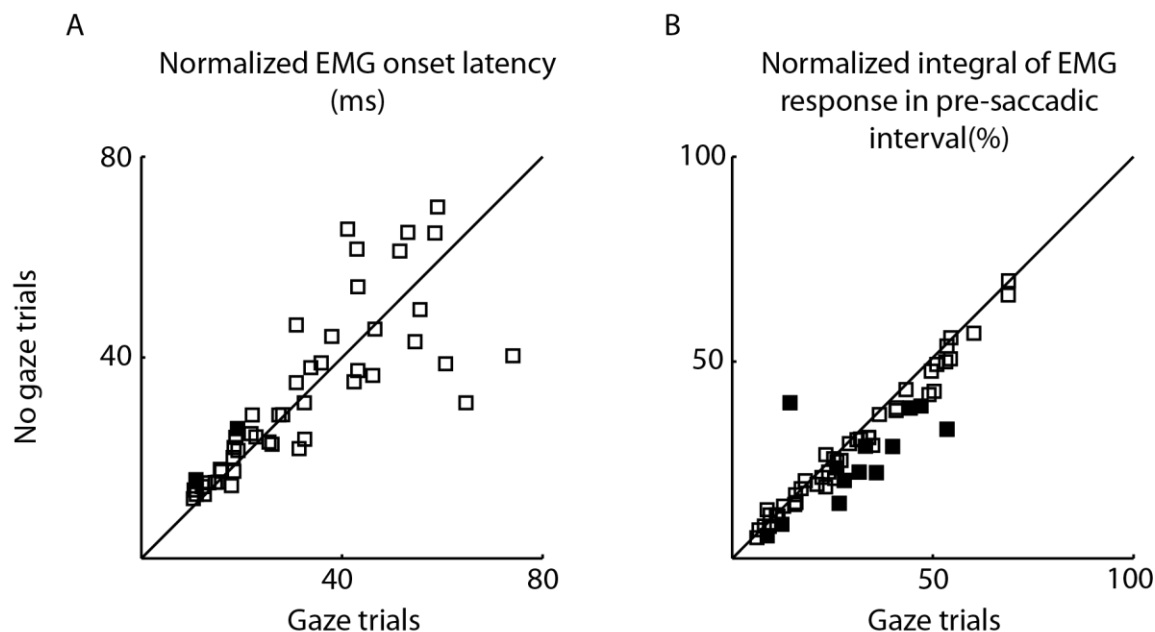

Figure 3-10. Comparison of EMG responses on trials with or without accompanying gaze shifts (labeled gaze and no gaze trials respectively) averaged across trial type for each site that met our inclusion criterion. A-B: comparison of evoked EMG response for gaze and no-gaze trials, contrasting the EMG onset latency (A) and the normalized mean integral (B) of the EMG response. Each square was taken from a unique stimulation site, with filled squares representing sites that were significantly different from each other (2-tailed t-test, $P < 0.05$). Integral data were normalized to maximal integral recorded within each monkey. Across our sample, EMG onset latency was slightly but not significantly shorter and normalized EMG integral was significantly larger on gaze trials (paired t-test, $P = 0.8$ and $P < 0.001$ respectively).

there was no significant difference between the EMG onset latencies between gaze and no-gaze trials (paired t-test, $P = 0.8$, Fig 3-10 A). Third, the EMG response was stronger on gaze trials when compared to no-gaze trials by $3.1 \pm 5.8\%$ (paired t-test, $P < 0.001$, Fig. 3-10 B). Together, these results suggest that SEF recruitment of the neck musculature occurs even in the absence of an overt gaze shift; with the evoked neck muscle response reaching greater magnitude on trials with an accompanying gaze shift.

3.3.8 - Head movement parameters on stimulation trials without a gaze shift

Our description of EMG activity in the absence of gaze movements suggests that SEF stimulation in the head-unrestrained condition has the potential to drive orienting head movements without a gaze shift. As reported by Chen and Walton (2005), we also observed a number of sites that evoked both head-only movements and eye-head gaze shifts. Gaze remained stable during a head only movement due to the vestibular-ocular reflex. Notably, we observed neck EMG responses regardless of whether a gaze shift occurred or only a head movement was elicited. Accordingly, a number of differences in the parameters of head movements also occurred in the gaze and no-gaze conditions.

To analyze such head movements across our sample of SEF sites examined in the head-unrestrained condition, we identified sites that matched a number of inclusion parameters. At least five trials where a gaze shift was evoked and five trials where only a head movement was evoked were required for a valid comparison. Of our 76 head-unrestrained sites, 28 unique sites matched these criteria. Our analysis then compared evoked head movements on trials with or without an accompanying gaze shift and revealed that a larger head movement was evoked on trials that had an accompanying

Figure 3-11. Comparison of head movement amplitude (A), peak head velocity (B) and mean integral (C) of the composite EMG response on trials with or without an accompanying gaze shift. Each square was taken from a unique stimulation site with filled squares representing measures that were significantly different within a given stimulation site (2-tailed t-test, $P < 0.05$). Integral data are normalized to maximum integral recorded within each monkey. Across our sample, head movement amplitude and peak velocity were significantly greater on gaze vs. no gaze trials (A: paired t-test, $P < 0.001$; B: paired t-test, $P < 0.001$), as was the magnitude of the evoked neck EMG response (paired t-test, $P < 0.05$).

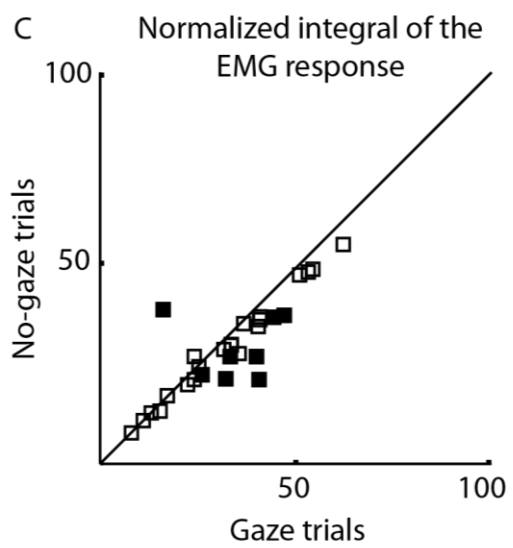
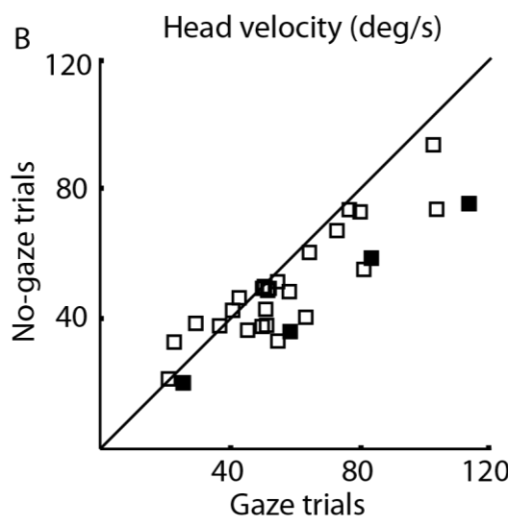
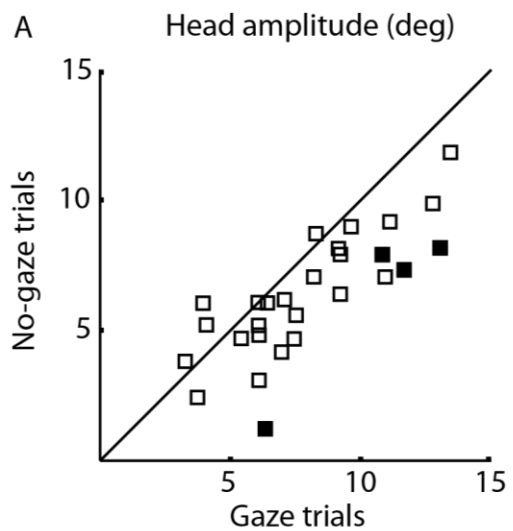

gaze shift (Fig. 3-11 A, paired t-test, $P < 0.001$). In addition, the head also moved faster when accompanied by a gaze shift (Fig. 3-11 B, paired t-test, $P < 0.001$). However, the timing of head movement onset did not differ on trials with or without an accompanying gaze shift (results not shown, paired t-test, $P = 0.37$). Our analysis on the composite EMG activity demonstrated that the EMG response was larger on the ‘gaze’ trials (Fig. 3-11 C, paired t-test, $P < 0.05$); however, onset latencies of EMG activity did not differ on trials with or without an accompanying gaze shift. (Results not shown, paired t-test, $P = 0.77$).

Our analysis of head movement during trials with or without and associated gaze shift demonstrated that larger EMG and head responses were observed on trials with an accompanying gaze shift.

3.3.9 - Comparison of volitional vs. evoked movements

Because stimulation of the SEF results in gaze shifts that appear kinematically similar to volitional movements (Martinez-Trujillo et al. 2003), we sought to identify if any differences are observed in the associated neck muscle activity. Here, we compare the EMG patterns accompanying gaze shifts evoked by SEF stimulation to those accompanying volitional gaze shifts made during control trials. The comparison of gaze shifts between evoked and volitional movements is limited due to our behavioral paradigm, where targets were placed at one of eight potential locations at 10° or 15° in the head-restrained condition or at 15° or 20° in the head-unrestrained condition (see methods). Although we wished to perform a detailed quantitative analysis on the metrics and timing of EMG activity associated with evoked and volitional head movements, we

did not have enough volitional head movements that matched the kinematic profile of evoked head movements. Therefore, we focused on stimulation sites where the evoked gaze shift vector brought the final gaze position within 2.5 deg (head-restrained) or 3.5 deg (head-unrestrained) of one of the target locations contralateral to stimulation. In Fig. 3-12 A we show a representative example of EMG data aligned to evoked gaze shift onset to EMG data on control trials, aligned to when the monkey initiated a gaze shift to a target contralateral to stimulation. EMG activity attained visibly larger magnitudes on stimulation trials. In contrast, the EMG activity during control trials was far more modest, with negligible amounts of activity prior to gaze shift onset. These trends persisted across our sample data, with EMG activation on all three turner muscles being greater on stimulation versus control trials (see Fig. 3-12 B). Although limited, this analysis suggests that the profile of neck muscle recruitment reaches a far greater magnitude during evoked versus volitional gaze shifts likely due to the microstimulation summing with activity present in the SEF.

3.3.10 - Evoked neck muscle responses on extensor muscles

Up until now, we have primarily focused on evoked responses on neck muscles primarily associated with head turns. However, SEF stimulation commonly evoked responses bilaterally on the extensor muscles BC and COM (see Fig. 3-1). In Fig. 3-13, we present EMG activity from both muscles accompanying an evoked gaze shift with a large upward component (12° U, 4° L). This example was recorded with the head restrained and demonstrates activity from muscles both contralateral and ipsilateral to

Figure 3-12. Comparison of EMG activity aligned to the onset of either evoked or volitional gaze shifts. A: representative example comparing EMG activity in the peri-gaze shift period during an evoked 15° leftward gaze shifts (top-half of plot) or during volitional gaze shifts made during control trials to a target located 15° to the right (bottom half of plot). Same format as Fig. 3-4 except superimposed white squares on the color plots represent either stimulation onset or target onset and vertical lines represent gaze shift onset. B: comparison of peak peri-gaze shift EMG activity for the interval from -20 ms before to 20 ms after gaze shift onset, plotting peak activity during stimulation trials as a function of peak EMG activity on control trials. All data are normalized to peak observation for a given muscle and a given monkey. Across our sample, evoked activity was greater for each muscle but only significantly for OCI (paired t-test, $P < 0.05$, $P = 0.1$, $P = 0.06$ for OCI, RCM and SP, respectively). Each symbol represents a comparison from a unique stimulation site to control trials obtained in the same experimental session. Squares denote data where the head was restrained and circles represent when the head was unrestrained. Filled symbols denote peaks that were significantly different at a given stimulation site (2-way t-test, $P < 0.05$). Data were only included if evoked gaze shift landed within either a 2.5 (head-restrained) or 3.5 (head-unrestrained) radius windows surrounding one of the control targets.

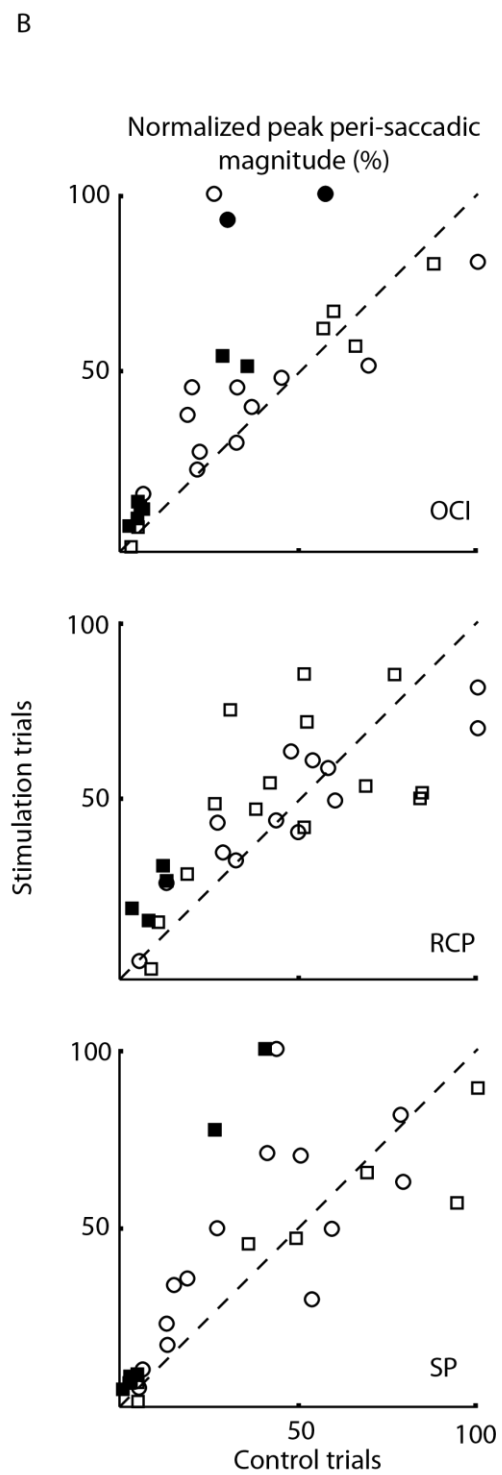
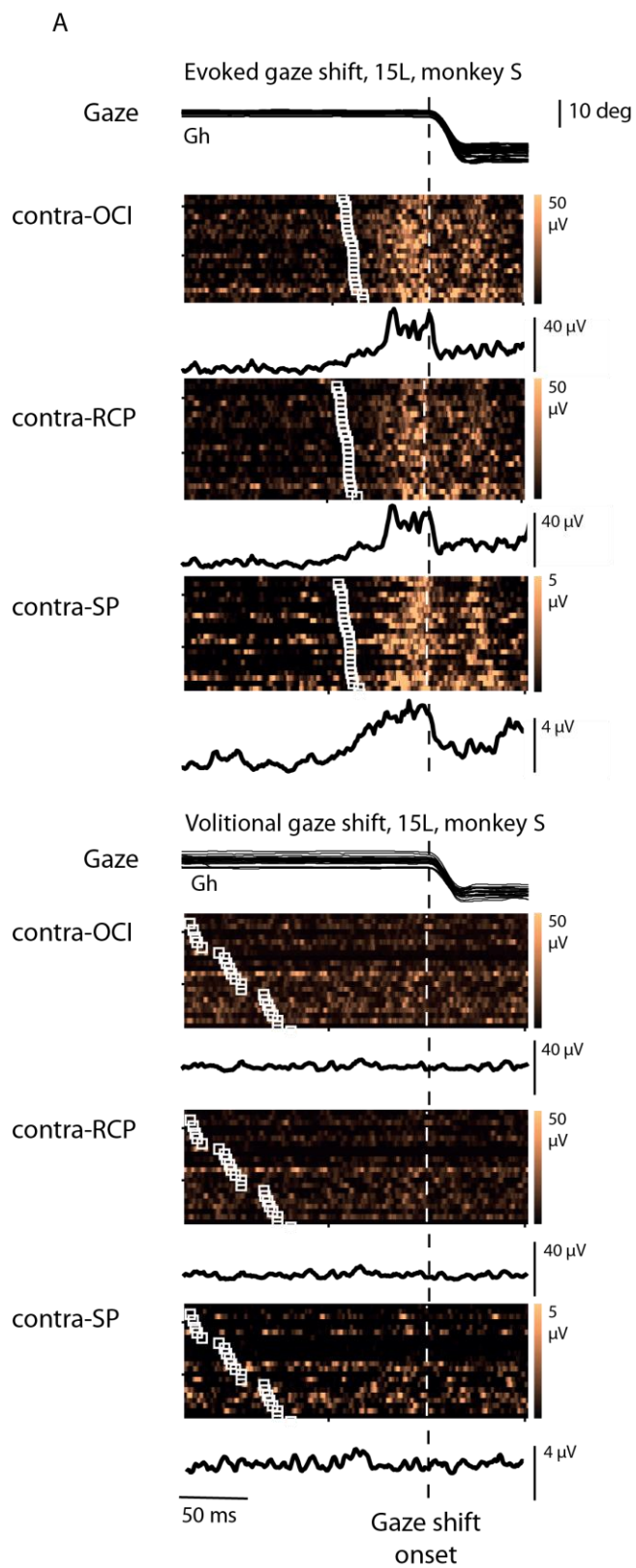
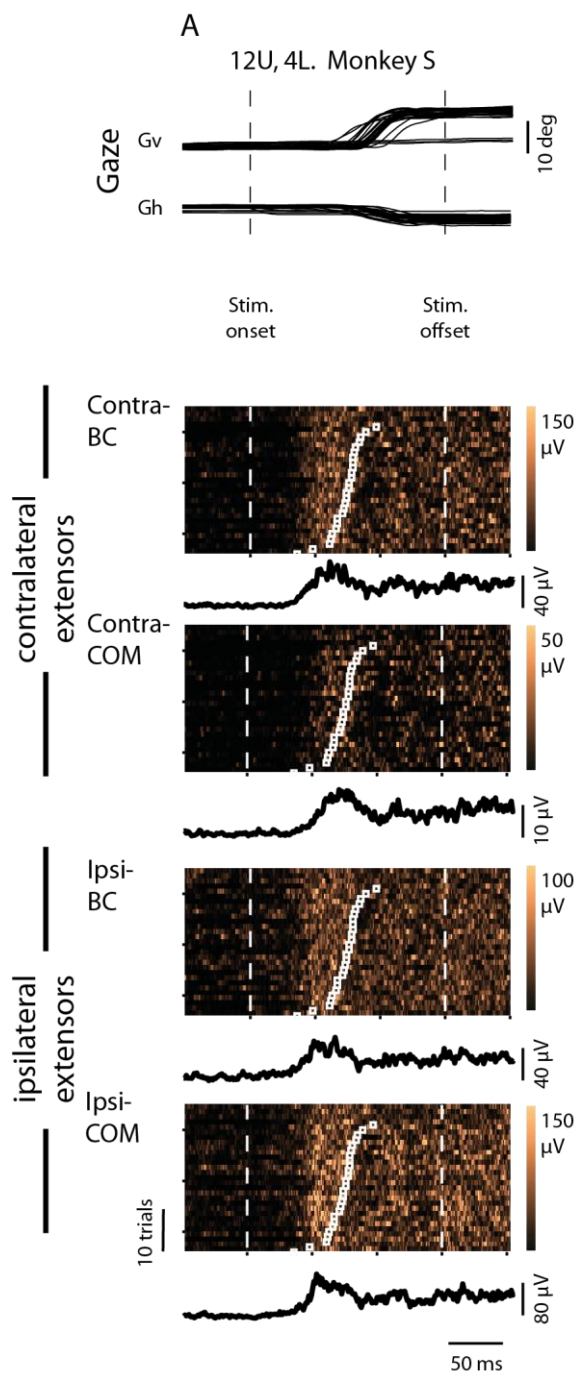

Figure 3-13. Gaze shifts and EMG activity evoked by SEF stimulation driving a predominantly upward gaze shift with the head restrained. Same format as Fig. 3-4, showing EMG activity for the contralateral and ipsilateral extensor muscles.



stimulation. Following SEF stimulation, which evoked a distinct upward gaze shift, bilateral facilitation of BC and COM was observed. Similar to the head turner muscles, EMG activity on the extensors occurred before the gaze shift and persisted throughout stimulation duration.

Across our sample, the facilitation latencies for extensor muscles (see Fig 3-14 A) tended to be similar when compared with the turner muscles (Fig 3-5). The mean facilitation latencies for contra-BC, contra-COM, ipsi-BC and ipsi-COM were 28.4 ± 13.8 ms (median = 25 ms), 35.4 ± 15.2 ms (median = 35 ms), 36.1 ± 17.3 ms (median = 36 ms) and 38.6 ± 17.7 ms (median = 35 ms) respectively. The facilitation latencies for contra-BC tended to be larger for gaze shifts with larger vertical components but surprisingly invariant across the other three muscles. Larger peak magnitudes were associated with gaze shifts with larger gaze components on the ipsilateral extensors; however, this relationship was not observed on the contralateral extensors (see Fig. 3-14 B).

3.4 - DISCUSSION

We have described neck EMG evoked by stimulation of the monkey SEF. Stimulation of the SEF occasionally evoked overt contralateral gaze shifts and/or head movements but almost always evoked a contralateral head turning synergy. Evoked neck muscle responses scaled with evoked movements, accompanied even small gaze shifts and were not influenced by head restraint. Neck EMG signals are endowed with a high temporal resolution, allowing for the observation that neck muscle responses began well

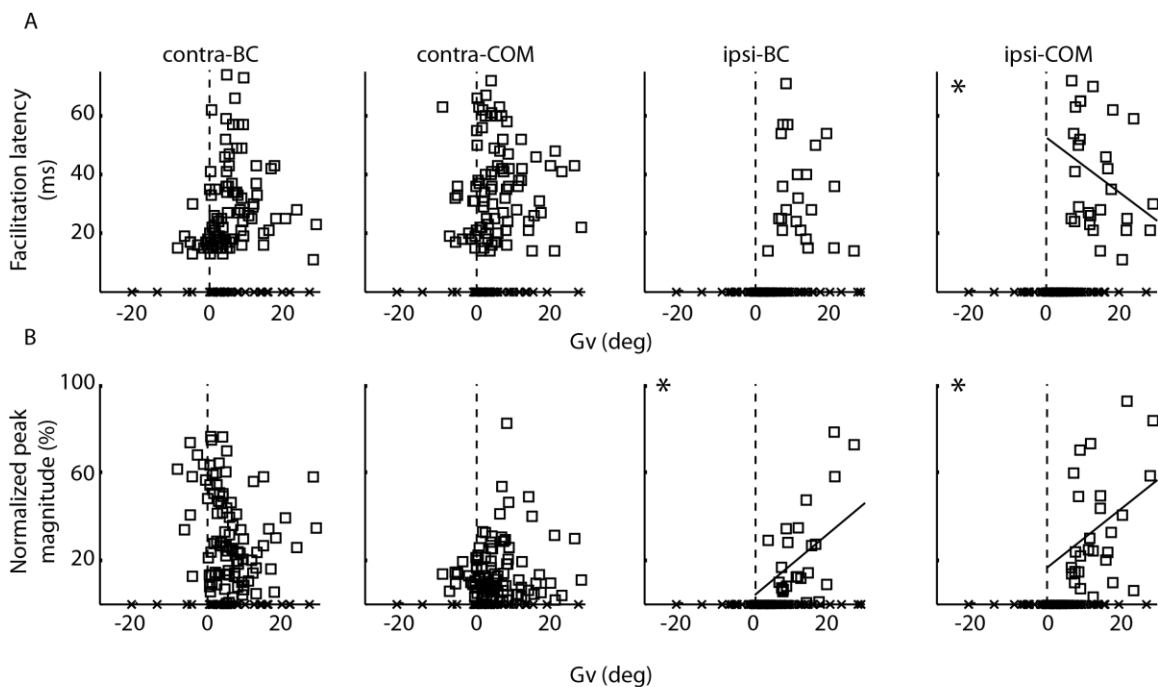

Figure 3-14. A-B: correlations of upward or downward evoked gaze shifts on extensor muscles and various parameters (A: facilitation latencies; B: normalized peak magnitude) with vertical component of evoked gaze shift. Subplots with * in top, left corner show regressions that were significant at $P < 0.05$.

in advance of evoked gaze shifts (~40 ms). Neck muscle activity also persisted on trials without an accompanying gaze shift. Together these observations suggest that the metrics and parameters of the EMG and gaze shift responses evoked from SEF stimulation are comparable to results evoked by FEF stimulation, emphasizing similar contributions of frontal oculomotor structures to orienting head movements. However, as will be described below, the latency of the neck muscle responses evoked from the SEF imposed on gaze shift initiation do not constrain neck muscle responses. The overall responses are considerably longer than those evoked from the FEF, consistent with a hierarchy where the SEF is further removed from the motor periphery compared to the FEF.

3.4.1 - Comparison to previous SEF studies

Research by Schlag and Schlag-Rey (1987) found that SEF stimulation evoked head movements at only one of ten sites studied, leading to the suggestion that the SEF was not directly involved in influencing head movement timing and kinematics. We believe that these results could have been caused by a small sample size that targeted locations associated with small saccades. Our results are in concurrence with the more recent findings (Martinez-Trujillo et al. 2003; Chen and Walton 2005) showing that SEF stimulation readily evokes eye-head gaze shifts.

Reports regarding the topography of evoked movements following SEF stimulation have been inconclusive. A rough topographic organization has been described along the rostral-caudal axis with larger movements being associated with more rostral positions and smaller movements located caudally (Tehovnik and Sommer

1997). Others have reported no systematic organization of evoked movements along the rostral-caudal or medial-lateral axes (Schlag and Schlag-Rey 1987). Apart from smooth pursuit movements being evoked from the caudal SEF in one monkey, we did not observe any topographic organization in any aspects of our evoked movements or neck muscle responses.

Despite considerable differences in the behavioral paradigm, our results compare favorably to other reports of eye-head gaze shifts evoked from SEF, providing further evidence that we were delivering stimulation to the SEF. In a series of studies conducted by Martinez-Trujillo and colleagues, stimulation was delivered after monkeys arrived at the location of a previously flashed stimulus placed throughout the visual field (Martinez-Trujillo et al. 2003; Martinez-Trujillo et al. 2003; Martinez-Trujillo et al. 2004). Gaze shifts and head movements began ~40 ms and ~55 ms after stimulation onset respectively. While these response latencies are considerably shorter than what we observed (~90 and ~70 ms for gaze and head respectively), our monkeys were looking straight ahead prior to stimulation onset. Chen and Walton (2005) trained monkeys to systematically dissociate the relative orientation of the eye and the head (i.e. gaze pointing to the right while the head is pointed straight forward). They reported a strong influence of initial head position on movement onset latencies, with head movements from center beginning ~ 125 ms after stimulation. Chen and Walton also found that head movement amplitude increased with longer stimulation duration. This finding likely relates to our neck EMG recordings showing an initial peak of activation followed by a sustained level of recruitment that persists for the duration of stimulation.

One surprising aspect of our results is that ~95% of all SEF sites evoked a neck muscle response. Both Martinez-Trujillo and colleagues and Chen and Walton reported a proportion of sites where head movements were not evoked regardless of initial fixation position (33% and 18% respectively). Based on our results, we suspect that many of the sites they classified as not evoking a head movement would have evoked a neck muscle response had it been measured. From the perspective of the evoked neck muscle activity, we saw little evidence for a population of ‘eye alone’ sites within the SEF. We suggest that whether the head moves or not depends on biomechanical issues such as whether the consequent forces arising from the evoked neck muscle responses can overcome the head’s inertia.

3.4.2 - Comparison to previous studies in the oculomotor system

A series of studies have paired stimulation with the recording of neck muscle activity in the primate FEF (Elsley et al. 2007), SC (Corneil et al. 2002b; Corneil et al. 2002a) and INC (Farshadmanesh et al. 2008). As with each of these areas, stimulation of the SEF resulted in the rapid recruitment of a contralateral head turning synergy that scales with the magnitude of any accompanying gaze shift. Given that our monkeys performed an identical task as that in the FEF study (Elsley et al. 2007), we can directly compare many aspects of our results. With the exception of the latency of the evoked response, virtually all of the results reported here were also observed in the FEF. Regardless of whether the stimulation is delivered to the SEF or FEF, evoked neck muscle responses precede gaze shifts, lead evoked head movements by ~40 ms, are not affected by head restraint, are larger on trials with an accompanying gaze shift, and

persisted on trials where stimulation failed to evoke a gaze shift. These similarities suggest that efferent projections from the SEF ultimately access the same brainstem orienting circuits as those accessed following FEF stimulation.

We also compared neck muscle activity across amplitude-matched evoked and volitional gaze shifts and found that evoked neck muscle activity was larger than volitional activity regardless of monkey, head restraint or muscle. This finding is similar to comparisons made following both FEF and SC stimulation (Elsley et al. 2007; Corneil et al. 2002a). Thus while head movements evoked from the SEF, FEF or SC appear kinematically normal (Martinez-Trujillo et al. 2003; Monteon et al. 2010; Freedman et al. 1996), the underlying neck muscle activity is quite different. These findings attest to the low-pass filtering characteristics of the head plant.

The main difference between neck muscle responses evoked from the SEF or FEF is in the response latencies. Neck muscle latencies following FEF stimulation are ~20 ms, and those following SC stimulation are ~17 ms (Corneil et al. 2002a). These values approach the minimal synaptic and conduction delays from the frontal cortex to the motor periphery with probable relays in the pontomedullary reticular formation (Elsley et al. 2007). Neck muscle responses from the SEF averaged 30 ms, which is substantially longer than one might expect if the signal was relayed directly through the FEF or SC. The difference between these results could be accounted for by the absence of a topographic representation of gaze shifts in the SEF compared to the FEF. SEF efferents are also distributed more widely throughout the SC than efferents from the FEF (Shook et al. 1990; Huerta M.F. and Kaas J.H. 1990), suggesting a more diffuse pattern of projections onto subcortical targets. It also appears that the density of saccade related

neurons is higher in the FEF than the SEF (Tehovnik and Sommer 1997). Taken together, we suggest that signals evoked by SEF stimulation take longer to propagate through to the motor periphery. This is presumably because the drive is weaker and less focal than that evoked by FEF stimulation. A weaker and more diffuse drive results in increased delays for temporal and spatial summation at each relay of the poly-synaptic pathway. Finally, the SEF may be less excitable at the time of stimulation compared to the FEF during this task.

3.4.3 - Possible pathways

Based on anatomy, there appear to be two major pathways for how a command evoked from SEF can get to neck muscle motoneurons (see Fig. 1-2). First, the signal can travel directly from the SEF to the premotor nuclei responsible for head movements. Second, the cephalomotor signal could access these premotor nuclei after relaying through the FEF and/or the SC. Our average conduction latencies are long enough that both alternatives are possible. Regardless, both pathways have similar access to the brainstem and the gaze command is separated into separate eye and head components downstream of the SC.

3.4.4 - Summary

The SEF has a likely role in linking abstract rules to action. These results detail the basic cephalomotor commands from the SEF and likely attest to hard wired connections to the motor periphery. We have demonstrated robust and widespread recruitment of a horizontal head turning synergy following stimulation of the SEF. This

basic description lays the groundwork for future studies investigating how this evoked response varies with experimental manipulations of initial eye-in-head and head-on-body configurations, or task context. While this evoked response does not depend on an accompanying gaze shift, we favor an interpretation that suggests the SEF is issuing a general orienting command, similar to the FEF and SC.

Reference List

- Amiez C, Petrides M (2009) Anatomical organization of the eye fields in the human and non-human primate frontal cortex. *Prog Neurobiol* 89:220-230
- Andre-Deshays C, Berthoz A, Revel M (1988) Eye-head coupling in humans. I. Simultaneous recording of isolated motor units in dorsal neck muscles and horizontal eye movements. *Exp Brain Res* 69:399-406
- Basso MA, Wurtz RH (1997) Modulation of neuronal activity by target uncertainty. *Nature* 389:66-69
- Berdyeva TK, Olson CR (2010) Rank signals in four areas of macaque frontal cortex during selection of actions and objects in serial order. *J Neurophysiol* 104:141-159
- Campos M, Breznen B, Andersen RA (2009) Separate representations of target and timing cue locations in the supplementary eye fields. *J Neurophysiol* 101:448-459
- Chapman, B. B. and Corneil, B. D. Properties of eye-head gaze shifts in an anti-gaze shift task. *Society for Neuroscience* . 2005. Ref Type: Abstract
- Chapman, B. B., Pace, M. A., and Corneil, B. D. Neck muscle activity following stimulation of primate SEF: influence of parameters and behavioural tasks. *Neural control of movement*. *Society for Neuroscience* . 2010.

- Chen LL, Walton MM (2005) Head movement evoked by electrical stimulation in the supplementary eye field of the rhesus monkey. *J Neurophysiol* 94:4502-4519
- Chen LL, Wise SP (1995) Supplementary eye field contrasted with the frontal eye field during acquisition of conditional oculomotor associations. *J Neurophysiol* 73:1122-1134
- Coe B, Tomihara K, Matsuzawa M, Hikosaka O (2002) Visual and anticipatory bias in three cortical eye fields of the monkey during an adaptive decision-making task. *J Neurosci* 22:5081-5090
- Corneil BD, Olivier E, Munoz DP (2002a) Neck muscle responses to stimulation of monkey superior colliculus. I. Topography and manipulation of stimulation parameters. *J Neurophysiol* 88:1980-1999
- Corneil BD, Olivier E, Munoz DP (2002b) Neck muscle responses to stimulation of monkey superior colliculus. II. Gaze shift initiation and volitional head movements. *J Neurophysiol* 88:2000-2018
- Corneil BD, Olivier E, Richmond FJ, Loeb GE, Munoz DP (2001) Neck muscles in the rhesus monkey. II. Electromyographic patterns of activation underlying postures and movements. *J Neurophysiol* 86:1729-1749
- Elsley JK, Nagy B, Cushing SL, Corneil BD (2007) Widespread presaccadic recruitment of neck muscles by stimulation of the primate frontal eye fields. *J Neurophysiol* 98:1333-1354

- Farshadmanesh F, Chang P, Wang H, Yan X, Corneil BD, Crawford JD (2008) Neck muscle synergies during stimulation and inactivation of the interstitial nucleus of Cajal (INC). *J Neurophysiol* 100:1677-1685
- Freedman EG, Stanford TR, Sparks DL (1996) Combined eye-head gaze shifts produced by electrical stimulation of the superior colliculus in rhesus monkeys. *J Neurophysiol* 76:927-952
- Fujii N, Mushiake H, Tamai M, Tanji J (1995) Microstimulation of the supplementary eye field during saccade preparation. *Neuroreport* 6:2565-2568
- Fujii N, Mushiake H, Tanji J (2002) Distribution of eye- and arm-movement-related neuronal activity in the SEF and in the SMA and Pre-SMA of monkeys. *J Neurophysiol* 87:2158-2166
- Huerta M.F., Kaas J.H. (1990) Supplementary eye field as defined by intracortical microstimulation: Connections in macaques. *J of Comp Neurol* 293,299
- Martinez-Trujillo JC, Klier EM, Wang H, Crawford JD (2003) Contribution of head movement to gaze command coding in monkey frontal cortex and superior colliculus. *J Neurophysiol* 90:2770-2776
- Martinez-Trujillo JC, Medendorp WP, Wang H, Crawford JD (2004) Frames of reference for eye-head gaze commands in primate supplementary eye fields. *Neuron* 44:1057-1066

- Missal M, Heinen SJ (2001) Facilitation of smooth pursuit initiation by electrical stimulation in the supplementary eye fields. *J Neurophysiol* 86:2413-2425
- Monteon JA, Constantin AG, Wang H, Martinez-Trujillo J, Crawford JD (2010) Electrical stimulation of the frontal eye fields in the head-free macaque evokes kinematically normal 3D gaze shifts. *J Neurophysiol* 104:3462-3475
- Moorman DE, Olson CR (2007) Combination of neuronal signals representing object-centered location and saccade direction in macaque supplementary eye field. *J Neurophysiol* 97:3554-3566
- Nachev P, Kennard C, Husain M (2008) Functional role of the supplementary and pre-supplementary motor areas. *Nat Rev Neurosci* 9:856-869
- Penfield W (1950) The supplementary motor area in the cerebral cortex of man. *Arch Psychiatr Nervenkr Z Gesamte Neurol Psychiatr* 185:670-674
- Russo GS, Bruce CJ (1993) Effect of eye position within the orbit on electrically elicited saccadic eye movements: a comparison of the macaque monkey's frontal and supplementary eye fields. *J Neurophysiol* 69:800-818
- Russo GS, Bruce CJ (1996) Neurons in the supplementary eye field of rhesus monkeys code visual targets and saccadic eye movements in an oculocentric coordinate system. *J Neurophysiol* 76:825-848

- Russo GS, Bruce CJ (2000) Supplementary eye field: representation of saccades and relationship between neural response fields and elicited eye movements. *J Neurophysiol* 84:2605-2621
- Schall JD (1991a) Neuronal activity related to visually guided saccades in the frontal eye fields of rhesus monkeys: comparison with supplementary eye fields. *J Neurophysiol* 66:559-579
- Schall JD (1991b) Neuronal activity related to visually guided saccadic eye movements in the supplementary motor area of rhesus monkeys. *J Neurophysiol* 66:530-558
- Schall JD, Stuphorn V, Brown JW (2002) Monitoring and control of action by the frontal lobes. *Neuron* 36:309-322
- Schlag J, Schlag-Rey M (1987) Evidence for a supplementary eye field. *J Neurophysiol* 57:179-200
- Shook BL, Schlag-Rey M, Schlag J (1990) Primate supplementary eye field: I. Comparative aspects of mesencephalic and pontine connections. *J Comp Neurol* 301:618-642
- Shook BL, Schlag-Rey M, Schlag J (1991) Primate supplementary eye field II. Comparative aspects of connections with the thalamus, corpus striatum, and related forebrain nuclei. *J Comp Neurol* 307:562-583
- Smith WK (1949) The frontal eye fields. In: Bucy PC (ed) *The Precentral Motor Cortex*. University Illinois Press, pp 314-316

So NY, Stuphorn V (2010) Supplementary eye field encodes option and action value for saccades with variable reward. *J Neurophysiol* 104:2634-2653

Stuphorn V, Taylor TL, Schall JD (2000) Performance monitoring by the supplementary eye field. *Nature* 408:857-860

Tehovnik EJ, Lee K (1993) The dorsomedial frontal cortex of the rhesus monkey: topographic representation of saccades evoked by electrical stimulation. *Exp Brain Res* 96:430-442

Tehovnik EJ, Sommer MA (1997) Electrically evoked saccades from the dorsomedial frontal cortex and frontal eye fields: a parametric evaluation reveals differences between areas. *Exp Brain Res* 117:369-378

Tehovnik EJ, Tolias AS, Sultan F, Slocum WM, Logothetis NK (2006) Direct and indirect activation of cortical neurons by electrical microstimulation. *J Neurophysiol* 96:512-521

Chapter 4

Contextual modulation of neck muscle activity evoked by stimulation of the supplementary eye fields

Brendan B. Chapman¹ and Brian D. Corneil¹⁻³

Graduate Program in Neuroscience¹
Departments of Physiology & Pharmacology² and Psychology³,
University of Western Ontario,
London, Ontario, Canada N6A 5C1

ABSTRACT

The supplementary eye fields (SEF) serve as an interface between higher-level cognitive control and lower-level motor performance. SEF activity is greater during oculomotor tasks such as the anti-saccade task that require a non-standard mapping between stimulus location and motor output. Stimulation of the SEF also evokes eye-head gaze shifts, consistent with this area's relationship with the oculomotor system. The goal of this project is to investigate whether the cephalomotor drive evoked by SEF stimulation depends on task context.

To do this, we leveraged the observation that short-duration SEF stimulation evokes neck muscle activity without disrupting gaze stability. Two monkeys were trained to generate pro- or anti-saccades toward or away from a peripheral stimulus depending on the color of the central fixation point. Across multiple trials, we passed short-duration SEF stimulation (100 μ A, 300 Hz, 30 ms) at one of eight different times during the trial (stimulation was only passed once on a given trial). This allowed us to construct a timeline of EMG activity without the confounds of an accompanying gaze shift. Although saccades were not evoked (hence the animals continued to perform the trial), stimulation resulted in increased reaction times and error rates on anti-saccade trials and a decrease in error rates on pro-saccade trials. Stimulation resulted in a brief expression of a head-turning synergy on neck muscles consisting of a facilitation or suppression (when background activity was present) of the activity of contralateral agonist or ipsilateral antagonist turning muscles, respectively. We found that evoked activity became greater as the subjects prepared to make an anti- compared to a pro-saccade. Notably, this

activity did not simply mirror baseline levels of EMG activity prior to stimulation onset, as this tended to be larger prior to the generation of pro-saccades.

These results provide further confirmation that the SEF modulates eye-head gaze shifts. More importantly, we have demonstrated an influence of the behavioral task on the neck EMG response evoked by SEF stimulation. This influence is consistent with the notion that the SEF may play a role in the contextual control of eye-head gaze shifts during more complex tasks.

4.1 - INTRODUCTION

The supplementary eye fields (SEF) are located in the dorso-medial part of the frontal cortex (Schlag and Schlag-Rey 1987). Direct and indirect pathways from the SEF to the oculomotor nuclei have been recognized (Shook et al. 1990). Stimulation of the SEF evokes saccades (Schlag and Schlag-Rey 1987) that are kinematically similar to volitional movements. In addition to a role in saccade generation, the SEF is involved in higher level, cognitive processing of relatively more complex tasks. The SEF has been implicated in the contextual control of movement, error and reward monitoring, learning conditional visuomotor relationships and execution of oculomotor sequencing (Olson and Gettner 2002; Chen and Wise 1995b; Stuphorn et al. 2000; Gaymard et al. 1990; Muri et al. 1995; Tobler and Muri 2002; Sommer and Tehovnik 1999; Schlag-Rey et al. 1997).

Recently, the SEF's have been implicated in eye-head coordination. Stimulation of the SEF resulted in gaze shift kinematics, such as their temporal structure, amplitude-velocity relationships and relative contribution of the head to the gaze shift that are indistinguishable from volitionally generated gaze shifts. These results suggest that the SEF explicitly encodes gaze shifts and the specific aspects of eye and head coordination are controlled downstream of the SEF (Martinez-Trujillo et al. 2003). By systematically varying the initial position of the eye and the head, it was verified that SEF stimulation can evoke head movements even in the absence of a gaze shift (Chen and Walton 2005). Although we have a basic understanding of how the SEF controls gaze shifts, to date, the SEF's role in the contextual control of eye-head coordination has not been examined.

The anti-saccade task is an important tool that allows the quantitative examination of the contextual control of movement (Hallett 1978). This task requires a subject to

suppress an orienting response towards a stimulus in favor of a volitional movement to the diametrically opposite position, thus providing a dissociation between stimulus and response. Research has demonstrated both the ‘bottom-up’ responses associated with stimulus onset and ‘top-down’ responses related to task instruction occur in many cortical and subcortical areas during anti-saccades (see Munoz and Everling 2004 for review). Recently, we have recorded neck muscle activity during anti-saccades, and demonstrated the reflections of both bottom-up and top-down processes can also be observed in the motor periphery (Chapman and Corneil 2011). We observed bottom-up, stimulus-driven responses on the neck muscles occurring ~ 60-70 ms after stimulus presentation. The bottom-up head turning synergy occurred on the ‘wrong’ neck muscle during anti-saccade trials. Top-down modulation of neck muscles also occurred prior to stimulus onset and reflected whether the animals were preparing to make a pro- or anti-saccade. Research utilizing electrophysiology, temporary and permanent inactivation and clinical populations have identified the importance of the SEF in providing task-appropriate signals for the contextual control of movement (Sommer and Tehovnik 1999; Schiller and Chou 1998; Amador et al. 2004; Schlag-Rey et al. 1997; Everling and Fischer 1998). Neural recordings have shown short-latency time-locked responses associated with stimulus onset in the SEF ~80 ms after stimulus onset (Schall 1991). In addition, pre-stimulus activity is higher for anti-saccades compared to pro-saccades (Amador et al. 2004; Schlag-Rey et al. 1997). Combined, these results suggest that the SEF is a possible candidate for producing the context-dependent cephalomotor commands observed on neck muscles during a pro- and anti-saccade task.

To examine this question, we combine SEF stimulation and neck muscle recordings during a pro- and anti-saccade task in non-human primates. In chapter 3, we evoked short latency EMG activity that occurred well before saccade onset throughout much of the SEF. Additionally, the EMG response persisted on trials with no accompanying gaze shift. Based on these results, we utilized short-duration stimulation (30 ms) to evoke neck EMG responses without evoking saccades. This is beneficial as it allows for assessment of evoked EMGs without the confounds of an accompanying eye movement. Our experimental design is similar to a previous report that delivered short-duration stimulation to the superior colliculus [SC (Corneil et al. 2007)]. The goal of the current project is to examine whether SEF stimulation evoked a neck muscle response that is modulated by the behavioral task. Such a finding would be consistent with a potential role for the SEF in the top-down control of eye-head gaze shifts.

Portions of this manuscript have been presented in abstract form (Chapman et al. 2010).

4.2 - METHODS

4.2.1 - Subjects and surgical procedures

Two male rhesus macaque monkeys (*Macaca mulatta*, monkeys S and Z) weighing approximately 12-14 kg performed this experiment. All training, surgical and experimental procedures were conducted in accordance with the Canadian Council on Animal Care policy on the use of laboratory animals and approved by the Animal Use Subcommittee of the University of Western Ontario Council on Animal Care (see

appendix 1). The monkey's health and weight were monitored daily by technicians and/or veterinarians at the university.

Each animal underwent two surgeries as described in chapter three. In the first surgery, a head post and scleral search coil were implanted and anchored into an acrylic implant to permit head-restraint and the monitoring of eye position, respectively (Judge et al., 1980). In addition, a recording cylinder was placed midline over the frontal lobes to allow for extracellular recording and microstimulation of the SEF (Stereotaxic coordinates: Monkey S; AP = 25, ML = 3. Monkey Z; AP = 24, ML = 2). In the second surgery, chronically indwelling bipolar hook electrodes were implanted bilaterally in five neck muscles that are involved in orienting the head both horizontally and vertically. We focus on obliquus capitis inferior, rectus capitis posterior major and splenius capitis (OCI, RCM and SP respectively, see Fig. 4-1). OCI and RCM are small suboccipital muscles and SP is a larger neck muscle which together form the core of the ipsilateral head-turning synergy in the monkey (Corneil et al. 2001).

4.2.2 - Microstimulation parameters

Microstimulation was delivered through tungsten microelectrodes (impedance of electrode ranged between 0.5-1.2 M Ω at 1Khz) lowered through a 23 gauge tube secured within a Delrin grid. Stimulation consisted of a train of biphasic stimulation pulses (cathodal first) delivered at a frequency of 300 Hz. Briefly, to be an eligible SEF site, stimulation of 100 μ A (200 ms, 300 Hz) had to elicit saccades from anywhere in the visual field (see Fig. 4-2 for stimulation locations). Data was occasionally collected from the same guide tube location. When data was collected in the same experimental session,

Figure 4-1: A) schematic drawing of dorsal horizontal head turning neck muscles. These muscles serve to orient the head ipsilaterally (i.e. right neck muscle orients the head to the right). Obliquus capitis inferior extends from the middle of the C2 vertebrae to the lateral edge of C1. Rectus capitis posterior major extends from the middle of the C2 vertebrae to the base of the skull. Splenius capitis is a relatively large muscle that originates in the nuchal midline and transverses to T3. B) Example of the anti-saccade task. Based on the colour of the fixation point, the monkey was required to look towards the stimulus (pro-saccade) or away from it (anti-saccade). C) Schematic diagram of presentation of stimulation during the pro- and anti-gaze shift task. FP = fixation point, S = stimulus, Stim = stimulation. Stimulation was only passed once on each trial; however, all eight stimulation time points were sampled across one block.

A.

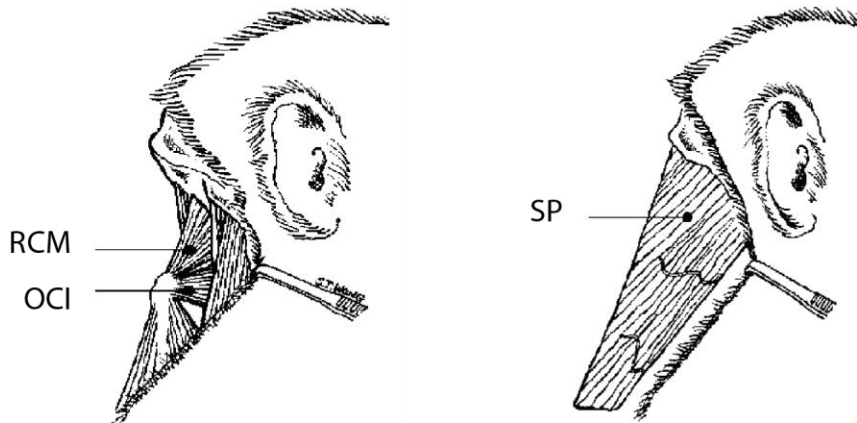

B.

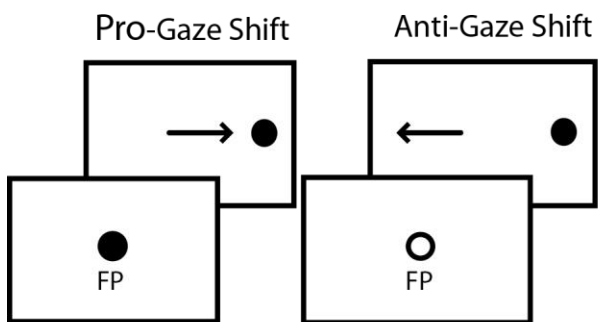

C.

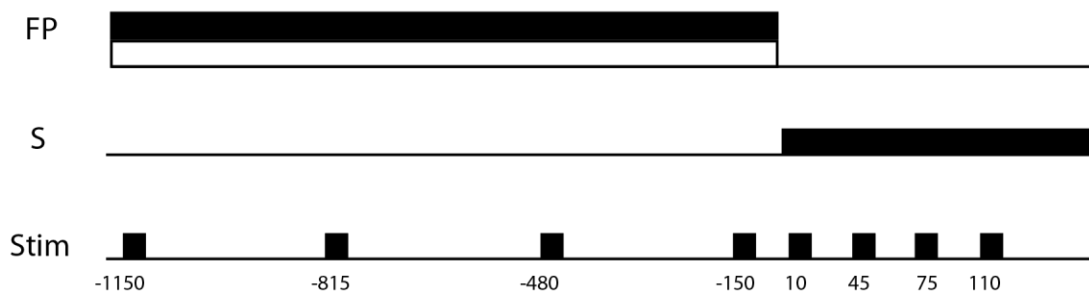

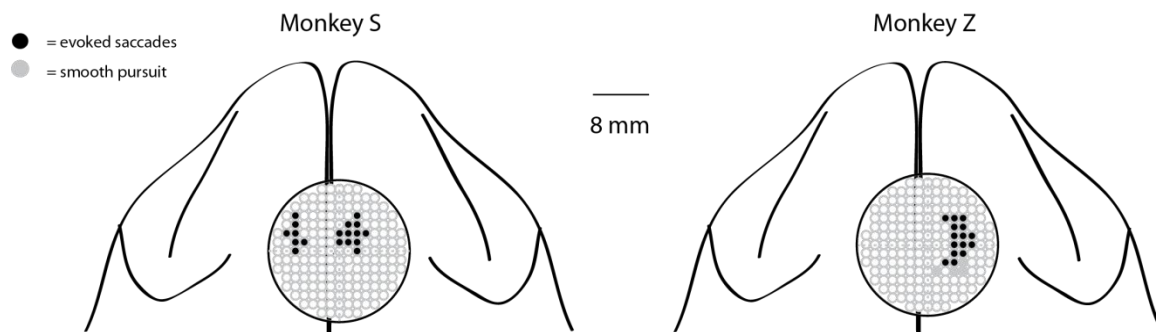

Figure 4-2: Schematic drawing of the dorsal view of the brain. Superimposed on this is the placement of the SEF chambers for monkeys S and Z. Black circles represent SEF sites where we evoked saccades from anywhere in the visual field and subsequently collected data using central FP. Grey circles represent SEF sites where smooth pursuit movements were evoked.

a difference of 500 μm was required between stimulation locations and a minimum of seven days was mandatory before returning to a previous location. This protocol allowed for data collection to be from a unique SEF site. Each individual pulse was 0.3 ms in duration, and the biphasic pulses were separated by 0.1 ms. Stimulation current was fixed at 100 μA and passed for 30 ms. After a SEF site was localized, all data were collected using the task described below.

4.2.3 - Behavioral and experimental parameters

Prior to SEF stimulation, monkeys were placed in a customized primate chair (designed and built in-house) designed to provide either complete restraint or complete movement of the head. Each monkey wore a customized primate jacket (Lomir Biomedical). The jacket was designed to allow complete motility of the head and neck but permitted researchers to attach the jacket and the chair in order to restrict trunk rotation to a maximum of 10° in any direction. The monkeys were then wheeled into the center of a 3-ft³ coil system (CNC engineering) which was located in a dark, sound-attenuated room. An array of tri-colored (red, green or orange), equiluminant LEDs were placed 24 inches in front of the monkey. Training on the anti-saccade task was the same for both monkeys and similar to the method described in chapter two. With the head restrained, monkeys were initially provided with a green central fixation point, followed by a red and a green stimulus on either side of the FP. Monkeys learned to look to the stimulus that was the same color as the FP. Following this, the intensity of the green stimulus was gradually reduced until it was completely extinguished and the monkeys were making correct anti-saccades by looking away from the red stimulus. It was not

necessary to colour match stimuli with red FPs as the monkeys were readily able to perform pro-saccades. Once the monkeys were capable of performing the task with the head restrained, the head was released so the monkeys could become accustomed to head-unrestrained anti-saccades. Data was collected in both the head restrained and unrestrained conditions.

Trials began with the removal of a diffuse, white background light that prevented dark adaptation. A red or a green FP was presented directly in front of the monkey. Based on the color of the fixation point, the monkeys were required to perform either a pro- or anti-saccade (red = pro-saccade, green = anti-saccade). The monkey was required to look at the FP within 1000 ms and hold gaze within a computer controlled window (radius of 2.5°) for a period of 1250 ms. A red stimulus was then presented randomly to the left or the right of the FP. In response to stimulus onset, the monkeys were required to correctly direct gaze either towards or away from the stimulus within 1000 ms. The monkeys were required to maintain fixation at the goal location for 600 ms. On anti-saccade trials, a stimulus was presented at the goal location half way through this period (i.e., lasted for 300 ms) to reinforce the task. A 1000 ms inter-trial interval was provided between each trial. One block consisted of ~600 correct trials of intermixed pro- and anti-saccade trial presented with equal probability. Within each block, stimuli were placed at a fixed horizontal eccentricity; however, between blocks, stimuli could be placed at either 10, 15 or 20° . For this experiment, we only collected data from sites that evoked a large horizontal component (the direction of evoked gaze shifts lay within ± 45 degrees of the horizontal meridian). Because evoked gaze shifts were largely horizontal, stimuli were always placed directly to the left or right of the FP allowing for potential

comparisons with EMG data collected in chapter two. We collected one block of trials for each unique stimulation site. Sub-blocks consisted of 20 pseudo-randomized trials (five trials for each unique combination of trial type and direction). A customized LABVIEW program controlled the experiment through a PXI controller (National Instruments) at 1 kHz. A liquid reward was provided at the end of each correct trial through a sipper tube that was attached to the head post. The sipper tube did not interfere in viewing the LEDs and moved with the head in the head-unrestrained condition.

Stimulation was administered on 66% of trials while the remaining 34% were control trials. Stimulation could be presented at one of eight different points. Four stimulation points were within the fixation period (1150, 815, 480 and 150 ms before stimulus onset) and four stimulation points were within the stimulus period (10, 45, 75 and 110 ms after stimulus onset). Stimulation was provided only once during a single trial, but all eight stimulation time points were equally sampled throughout one block of trials.

4.2.4 - Data collection and processing

The acquisition of EMG signals was described in detail in the two previous chapters. In brief, the recording of EMG activity began at an EMG connector that was plugged directly into a head stage that was embedded in the acrylic implant. The headstage (Plexon) performed differential amplification of the EMG signals (20x gain) and filtering of the signal (bandwidth, 20 Hz to 17 kHz). The headstage was connected to the preamplifier (Plexon) by a flexible ribbon cable. The preamplifier contained a signal processing board customized for EMG recordings (50x gain; bandwidth, 100 Hz to 4

kHz). All analog signals were digitized at 10 kHz. EMG signals were notch filtered to remove 60-Hz noise, rectified, and integrated into 1 ms bins offline, using a rationale described previously (Bak and Loeb 1979). These steps attenuated the digitized peak-to-peak amplitudes by a factor of ~3.

A second coil was secured to the head post in the frontal plane in order to measure head movement. Gaze (eye-in-space) and head (head-in-space) movements were filtered, amplified and digitized at a rate of 10 kHz onto a MAP box (Plexon). Signals were downsampled offline by a factor of 10 resulting in a 1 kHz signal. Throughout the experiment, monkeys were monitored through infrared cameras that were placed outside the monkey's line of site.

Offline analysis of eye, head, gaze and EMG signals was conducted using customized MATLAB (The Mathworks) programs. An interface was designed that permitted an analyst to perform trial-by-trial investigation of all trials. Trials could be discarded if necessary (i.e. if trials showed aberrant patterns of gaze shift movements or excessive stimulation artifacts were found on the EMG signal). The program automatically detected onset and offset thresholds for gaze shifts and head movements based on the movement's velocity (30 °/s and 10 °/s respectively). Customized MATLAB programs extracted aspects of behavioral performance and neck muscle activity.

4.3 - RESULTS

Stimulation was delivered to a number of different sites from within the SEF in two monkeys. Although stimulation of the SEF can result in contralateral gaze shifts, short-duration stimulation evoked neck muscle responses without eliciting an eye or head

movement. Following our acceptance criteria for identifying a unique SEF site, neck muscle responses were evoked from a total of 52 sites (24 in monkey S and 28 in monkey Z) with short-duration stimulation parameters (100 μ A, 30 ms and 300 Hz). 38 of these sites were collected with the head-restrained and 14 of these sites with the head-unrestrained. A total of >33 000 trials was collected from both monkeys with the head either restrained or unrestrained.

4.3.1 - Task specific behavioral effects following short-duration stimulation of the SEF

As previously mentioned, all data were collected using short-duration stimulation when the monkey fixated upon a central LED. Although evoked movements were not observed, stimulation influenced both reaction times and error rates in a task dependant manner. We characterized RTs using a modulation index (MI) for both pro- and anti-saccades:

$$MI = ([\text{STIM RTs} - \text{CONTROL RTs}] / [\text{STIM RTs} + \text{CONTROL RTs}])$$

Therefore, MIs > 0 represent RTs that were greater on stimulation trials than control trials. On control trials, RTs on pro-saccades were significantly shorter than anti-saccades (PRO RT = 239 \pm 44 ms, ANTI RT = 296 \pm 47 ms, paired t-test, P < 0.001). Figure 4-3 A plots the population MIs of RTs across all eight stimulation time points in both the pro-saccade condition. Figure 4-3 B shows RT data for anti-saccade trials using the same format.

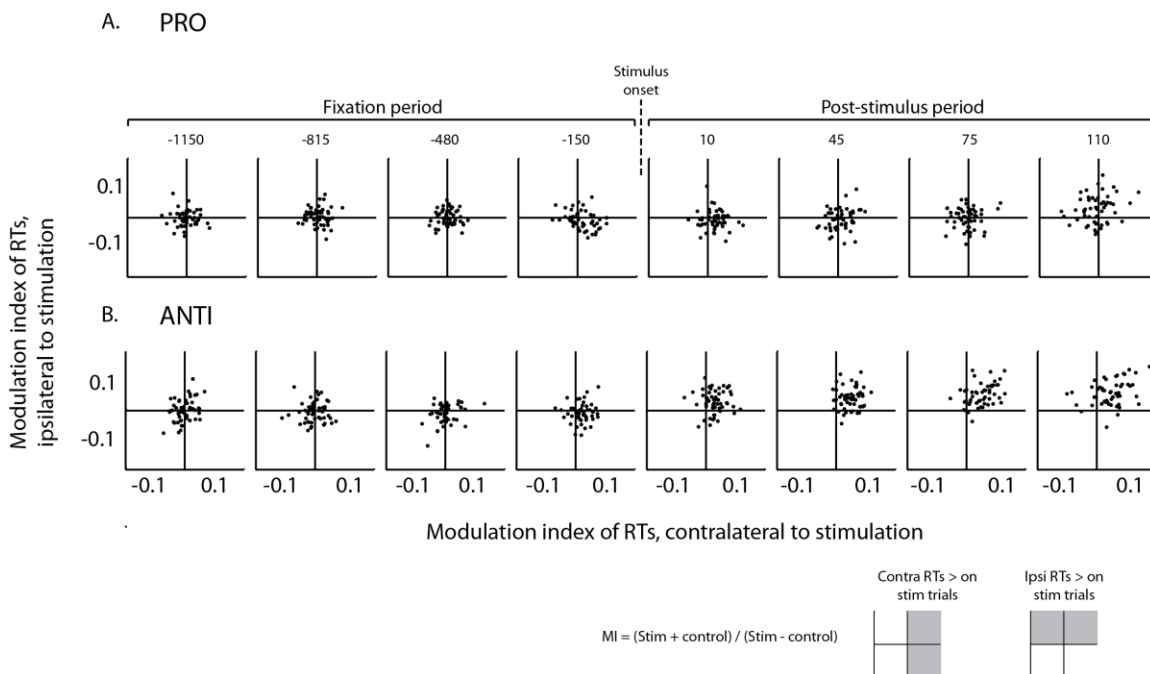

Figure 4-3: Plot of the modulation indices of RTs on movements contralateral to stimulation vs. RTs ipsilateral to stimulation. Each data point represents data from a unique stimulation location across both monkeys and across head restraint. The top row plots the modulation index for RTs following all eight stimulation time points in the pro-saccade condition while the bottom row plots the modulation index for RT data in the anti-saccade condition. Data points to the right of the vertical line show that contralateral RTs were prolonged by stimulation. Data points above of the horizontal line show that ipsilateral RTs were prolonged by stimulation (see insets).

A 3-way ANOVA was conducted to compare the effects of task (pro and anti), direction (ipsilateral and contralateral) and time of stimulation. A significant main effect was found for all three factors ($P < 0.05$). In addition, the interaction effect was significant for all groupings including the three-way interaction ($P < 0.01$) except for the interaction of task and direction.

During the fixation period data points for both pro- and anti-saccades tend cluster around the middle of each graph. However, the RTs of contralateral saccades increased during the late fixation period for pro-saccades, and the RTs of both contralateral and ipsilateral saccades increased substantially during the stimulation interval by ~10% for anti-saccades (note how data cluster in the upper-right quadrant). These patterns of RT changes demonstrate a task-dependent influence of SEF stimulation on RTs, with stimulation selectively increasing bilateral RTs when delivered just before the generation of anti-saccades.

Next, we analyzed error rates across pro- and anti-saccade trials and the direction of the goal location relative to stimulation (Fig 4-4). We plot the population error rates for both control trials (horizontal shaded lines in each graph representing the mean \pm standard error) and for each of the eight different time, task and direction conditions. Error rates on control trials ranged from 6-8% on pro-saccade trials (contra = $6.1 \pm 0.9\%$; ipsi = $7.5 \pm 1.1\%$) and 11-14% on anti-saccade (contra = $11.3 \pm 0.8\%$; ipsi = $13.6 \pm 1.1\%$). Stimulation during the fixation period did not appear to influence error rates on either pro- and anti-saccade trials. For error rates in the post-stimulus period, a noticeable difference can be observed. However, error rates following stimulation in the post-stimulus period displayed a dependency with the task, progressively increasing

Figure 4-4: Plot of population error rates for control trials and each of the eight stimulation time points relative to stimulation. All data are pooled across both monkeys and across head restraint. The two horizontal lines represent the mean error rate \pm the standard error on control trials. Data for each stimulation time point represent the mean error rate \pm the standard error. Data is broken down across trial type (top row = pro-saccades, bottom row = anti-saccades) and saccade duration relative to stimulation (contralateral = left column, ipsilateral = right column). Filled in squares represent significant differences between evoked and control error rates at a level of $P = 0.05$ corrected for multiple comparisons.

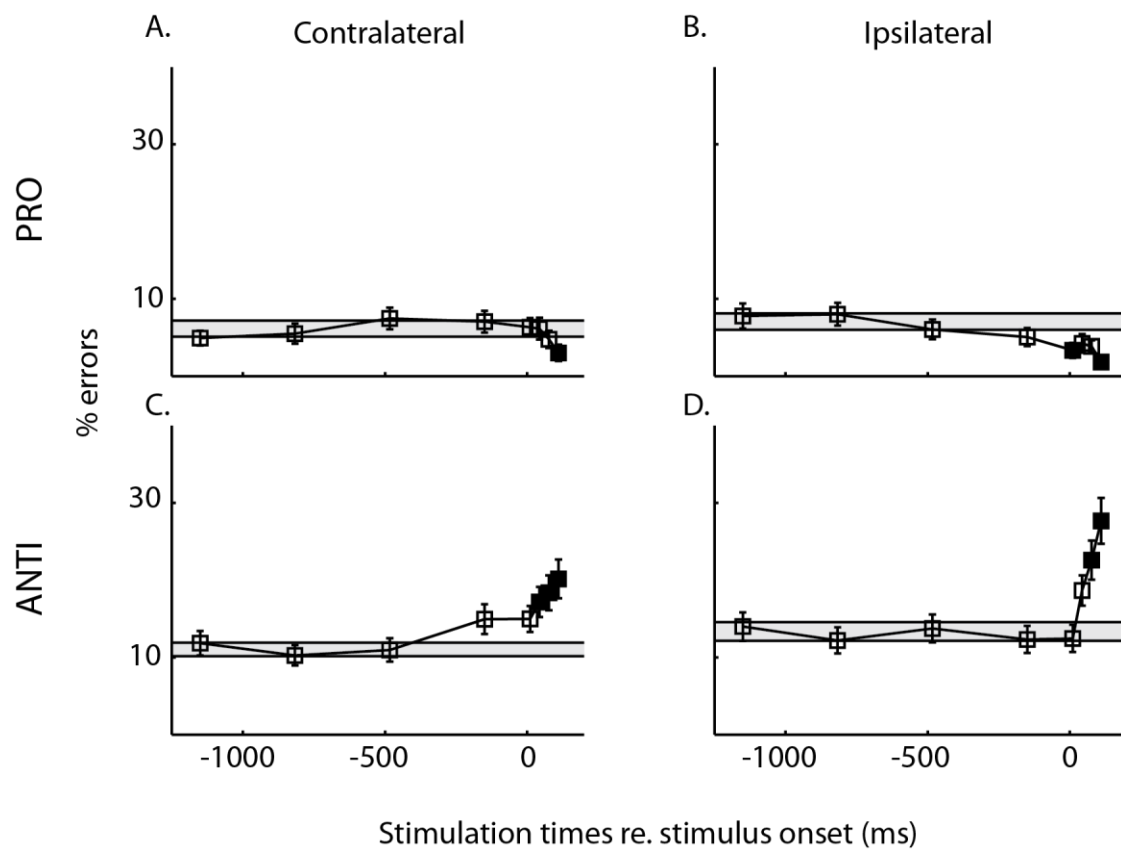

when stimulation was applied during anti-saccade trials (final stimulation time point contra = $19.7 \pm 2.4\%$; ipsi = $27.3 \pm 2.8\%$) and decreasing when stimulation was applied during pro-saccades (final stimulation time point contra = $3.4 \pm 1\%$; ipsi = $2 \pm 0.7\%$). We conducted a 3-way ANOVA including the variables of task (pro and anti), goal-location (ipsilateral or contralateral to stimulation) and time of stimulation (eight different stimulation time points). A significant main effect was found for both task and time of stimulation ($P < 0.001$ for both variables) but not for goal-location. All three 2-way interactions reached significance ($P < 0.05$ for each interaction); however, the 3-way interaction failed to reach significance. Thus, as with saccadic RTs, a greater effect of stimulation on error rates was seen in anti-saccade trials.

4.3.2 - Profile of neck EMG evoked by short-duration SEF stimulation

Short duration stimulation reliably influenced the activity of the three head turning muscles. Figure 4-5 plots EMG activity from a single representative site combining activity following all eight stimulation time points in both pro- and anti-saccade trials. On all three contralateral muscles, a robust EMG response was evoked ~15-25 ms subsequent to stimulation. This stimulation evoked response was followed by a short period of inhibition. On neck muscles ipsilateral to stimulation we found a reciprocal pattern of activity. Inhibition was observed ~15-25 ms after stimulation followed by a brief period of excitation of the muscle. This pattern of activity is the head turning synergy evoked by longer duration stimulation which we described in chapter three. Background activity is characterized as the average activity 50 ms prior to

Figure 4-5: Plot of representative EMG activity evoked following SEF stimulation. All data are combined across both pro- and anti-saccade trials and all eight stimulation time points. Traces represent the mean EMG activity \pm the standard error. The top three plots are for contralateral OCI, RCM and SP neck muscles respectively. The bottom plot is activity from ipsilateral OCI only.

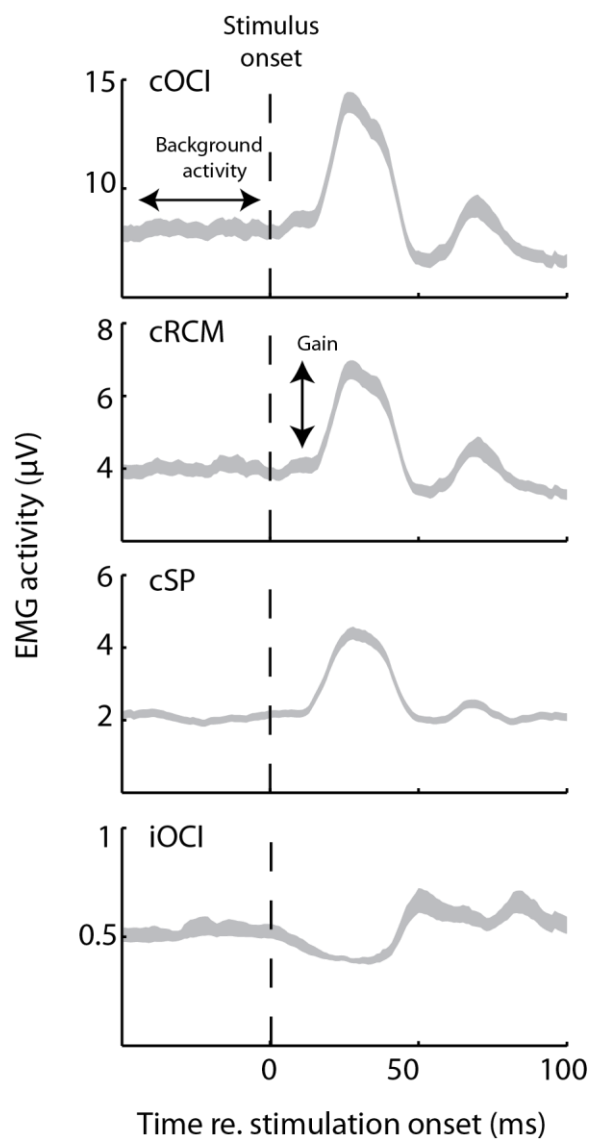

stimulation. The gain of EMG activity is calculated by measuring the rise of EMG activity above baseline.

4.3.3 - Increased evoked neck EMG activity during the preparation for anti- vs. pro-saccades

We first describe the patterns of EMG activity following stimulation passed during different stages of the fixation period. We also include the first stimulation time point in the stimulus interval (10 ms after stimulus presentation), as this time point precedes the arrival of visual information in the brain. Once again, stimulation during the fixation period rarely, if ever, evoked a saccade or gaze shift. Figure 4-6 plots the EMG activity on control trials from a representative site, and the evoked activity during the preparation of both pro- (light blue) and anti-saccades (light red). EMG activity on control trials is plotted for the 1250 ms prior to stimulus onset (time 0). Early in the fixation period, no observed difference in control activity is found between trials. As time progressed towards stimulus onset, the baseline activity increased progressively for pro- compared to anti-saccade trials. This pattern resembles that shown in monkey *gr* in chapter 2 (Fig. 2-8). Superimposed on the control trial activity is the evoked activity in the 50 ms following SEF stimulation for both pro- (blue traces) and anti-saccades (red traces). Even though baseline activity on control trials is similar for pro- and anti-saccades, for two of the first three stimulation points, evoked activity on pro-saccade trials is larger when compared to anti-saccades. However, as stimulation is applied closer to stimulus onset, evoked EMG activity becomes larger on anti-saccades. Figure 4-6 B plots the background EMG activity on the r-OCI for the representative sample. Note how

Figure 4-6: A. Time (ms) relative to stimulus onset is plotted against EMG activity for our representative site in Monkey S. Background EMG activity is plotted for control trials on both pro- (light blue) and anti-saccade (light red) trials. Evoked activity for the first five stimulation time points is superimposed on the graph with pro-saccade trials in blue and anti-saccade trials in red. Activity is plotted for the 50 ms following stimulation. All activity is shown as the mean \pm standard error. B. Plot of r-OCI activity across the first 5 stimulation time points for our representative site in monkey S. Squares denote mean EMG activity across all trials collected during that experimental session. The mean is subtended by the standard error. Upper plot depicts the background activity (i.e. average of activity 50 ms before stimulation). The lower graph plots the gain activity (peak EMG activity – background activity).

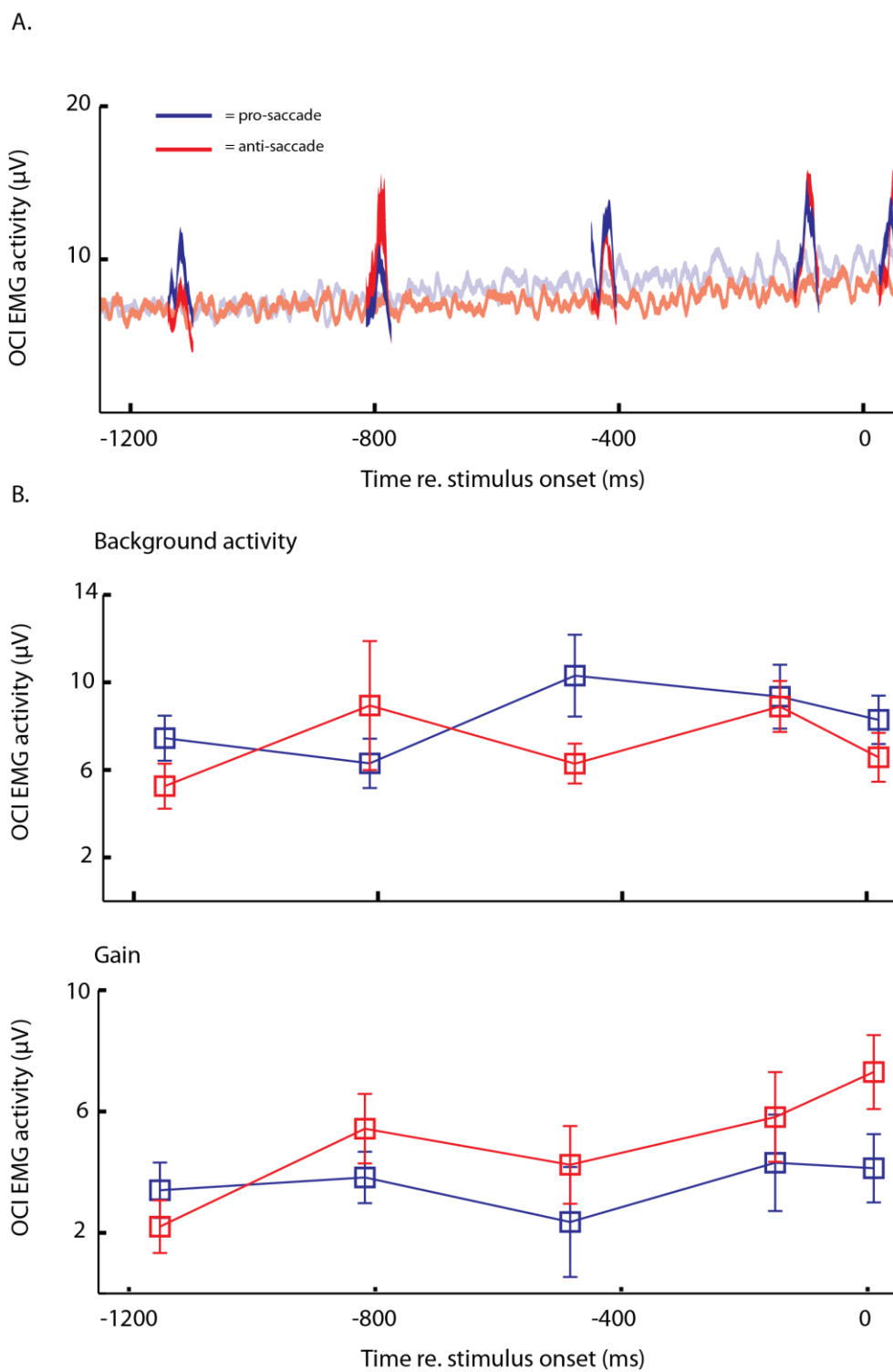

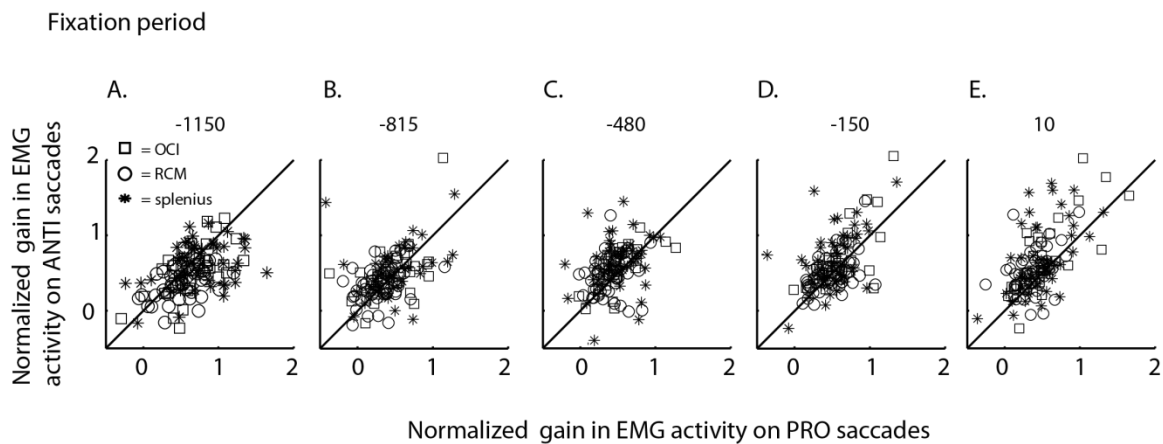

Figure 4-7: Population plots of normalized evoked EMG activity at the first five stimulation time points. We plot pro-saccade activity as a function of anti-saccade activity. Each point represents evoked activity from one of the three neck muscles (square = OCI, circle = RCM and star = SP) for a unique stimulation site from both monkeys regardless of head-restraint.

there is no difference between background activity on pro- or anti-saccades at any stimulation time point. Figure 4-6 C plots the rise above baseline of activity on the r-OCI for our representative sample. Note how, anti-saccade activity become larger as stimulation is delivered later in the fixation interval even though there is no difference in background activity. Across our sample, we observed a progressively increasing evoked response on anti-saccade trials during the consolidation of task instruction (Fig 4-7). To show this, normalized evoked EMG activity is plotted for both monkeys and all three horizontal head turning muscles. Data are normalized to the average amount of evoked activity in the earliest stimulation interval. For the first two stimulation time points, we observed no significant difference between evoked pro- and anti-saccade activity (Fig. 4-7 A. mean normalized EMG activity pro = 0.39, anti = 0.4. B. mean normalized EMG activity pro = 0.33, anti = 0.36. Paired t-test between normalized pro- and anti-saccade EMG activity, $P = 0.46$ and 0.14 respectively for Fig. 4-7 A and B). For the last three stimulation time points during fixation, short-duration SEF stimulation evoked a significantly greater response delivered on anti-saccades (Fig 4-7 C. mean normalized EMG activity pro = 0.29, anti = 0.34. D. mean normalized EMG activity pro = 0.3, anti = 0.39. E. mean normalized EMG activity pro = 0.31, anti = 0.45. Paired t-test between normalized EMG activity on pro- and anti- trials, $P < 0.05$, 0.001 and 0.001 respectively for Fig. 4-7 C, D and E).

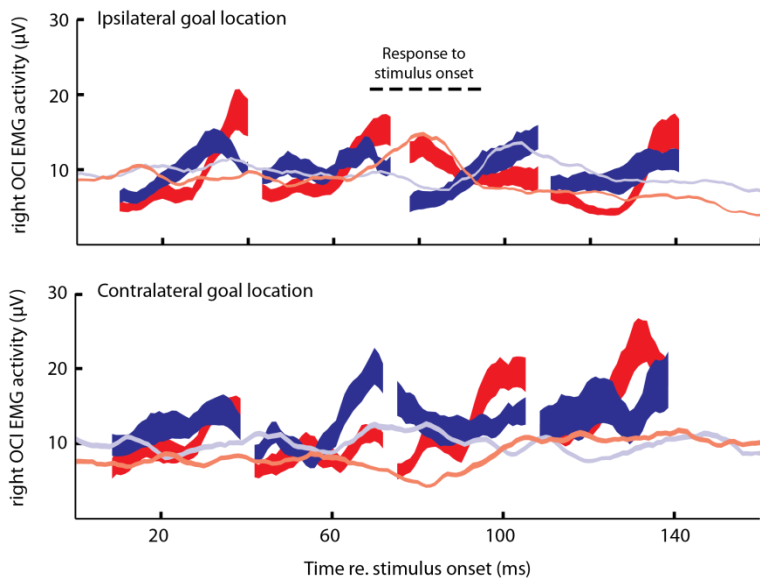

Figure 4-8: Background and evoked activity for the same representative site shown in Fig. 4-5. Data is represented in the same format as described in Fig. 4-5. Because visual information is accessible, data is broken down across neck muscle ipsilateral to stimulation (top) and contralateral to stimulation (bottom).

4.3.4 - Task dependent modulation in the post-stimulus period

Next, we analyzed EMG activity following control and stimulation trials in the post-stimulus period, segregating our data further based on saccade direction. Figure 4-8 presents EMG activity from the right-OCI for a representative SEF site during control, pro- and anti-saccade trials (figure is constructed as described in Fig. 4-6). Baseline activity on control trials is shown for the 150 ms after stimulus onset (time 0). Early in the post-stimulus period, no difference is observed between pro- and anti-saccade baseline activity for either goal location. Shortly after stimulus onset (~65 ms), a bottom-up visual response is observed on the neck muscles (see horizontal dotted line). For the ipsilateral goal location, the stimulus for pro-saccades is presented on the left, therefore a decrease is observed in activity on the right-OCI followed by a sustained increase in activity. On anti-saccade trials the stimulus is presented on the right, therefore, the right-OCI shows a transient increase in activity. A corresponding pattern of activity is found with a contralateral goal location (i.e. the increase and decrease occurs in the right-OCI during pro- and anti-saccades respectively). The timing and location of the visual burst is similar to what was described in chapter two.

In this figure, we also represent evoked EMG activity for 30 ms following SEF stimulation. Focusing on the ipsilateral goal location, the differences that occur between evoked EMG activity on pro- and anti-saccade trials are due to changes in the baseline activity. Specifically, the summation of evoked activity with the visual response can be seen on pro-saccade trials, while the associated inhibition during this same time period can be seen on anti- saccade trials. For the contralateral goal location, aspects of the visual response are reflected in the evoked activity. However, for the last two stimulation

time points, no difference is observed in the background activity, yet evoked activity is larger on anti-saccade trials.

Figure 4-9 plots the population modulation indices for evoked EMG activity on pro-saccades against anti-saccades during the post-stimulus period. (presented data are always from the right muscles).

$$MI = [\text{contra goal location} - \text{ipsi goal location}] / [\text{contra goal location} + \text{ipsi goal location}]$$

For the first stimulation time point, no difference is observed in evoked EMG for contralateral and ipsilateral goal locations on both pro- and anti-saccade trials (MI for pro-saccades = -0.07, anti-saccades = -0.9). As visual information summates with evoked activity on both pro- and anti-saccade trials, data points cluster in the bottom right quadrant for the second graph (MI for pro-saccades = 0.21, anti-saccades = -0.25). This is consistent with an increase in activity for pro- and anti-saccades with a contralateral and ipsilateral goal location respectively. For the third time point, no difference is observed between evoked EMG activity on pro-saccade trials as data points cluster around the vertical line (MI = -0.07). However, the data points cluster above the horizontal line suggesting significantly greater activity on during anti-saccade trials with a contralateral goal location (MI = 1.2). The final stimulation time point demonstrates the same trends as those observed in the third graph (MI for pro-saccades = 0.17, anti-saccades = 0.47). A 3-way ANOVA was conducted using the variables of task (pro and anti), goal location (ipsilateral and contralateral to stimulation) and time of stimulation

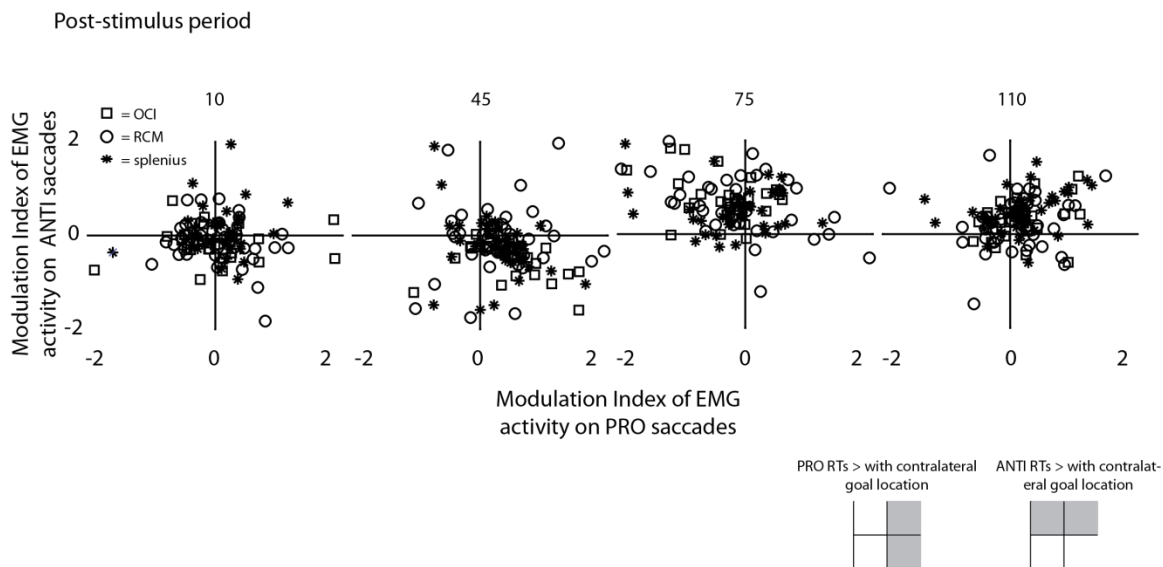

Figure 4-9: Modulation indices of pro-saccade EMG activity plotted as a function of anti-saccade EMG activity. Population data are from each neck muscle (square = OCI, circle = RCM and star = SP). Data are collapsed across each unique stimulation site, across both monkeys, and across head restraint. Data points to the right of the vertical line represent larger EMG activity on neck muscles contralateral to stimulation while data points to the left of the vertical line represent larger EMG activity on ipsilateral neck muscles. Data points above the horizontal line represent larger EMG activity on neck muscles contralateral to stimulation while data points below the horizontal line represent larger EMG activity on ipsilateral neck muscles.

(four stimulation time points in post-stimulus period). Significant main effects were found for all three variables ($P < 0.001$ for each variable) and significant interactions were found for all combination of variables, including the 3-way interaction ($P < 0.001$) except for the interaction of task and time of stimulation. These results suggest that a context-dependant, lateralized signal occurs on the sampled neck muscles following SEF stimulation.

4.4 - DISCUSSION

We have described neck muscle activity following short-duration SEF stimulation while monkeys performed a pro- and anti-saccade task with the head restrained and unrestrained. Stimulation throughout the SEF resulted in behavioral changes including increased RTs and error rates on anti-saccade trials and decreased error rates on pro-saccade trials. However, these effects only occurred when stimulation followed stimulus presentation. Short duration stimulation of the SEF also resulted in a contralateral head turning synergy, without producing an overt change in the gaze axis. In addition, greater EMG activity was evoked on anti-saccade trials when stimulation was delivered late in the fixation interval and only when the stimulus was presented contralateral to stimulation in the post-stimulus period. Overall, these results show a task dependent modulation that is consistent with a potential role for the SEFs in the contextual influence of behavior and it extends to the control of eye-head gaze shifts.

4.4.1 - Behavioral effects of SEF stimulation

Short-duration stimulation of the SEF altered behavioral responses during the progression of the pro- and anti-saccade task, regardless of head restraint. We have now shown that short-duration stimulation significantly changed RTs. These changes were context dependant; resulting in a 15% increase in anti-saccade RTs, while not affecting pro-saccade RTs. Additionally, this response occurred regardless of the direction of the ensuing gaze shift. Our results also reveal a bilateral increase in error rates on anti-saccades and a decrease in error rates on pro-saccades. These observations suggest a role for the SEF for influencing the contextual control of behavior. It is unlikely that the SEF is the lone neural area affecting context dependant actions, but this activity is likely complementary with other frontal cortical areas such as the dlPFC.

Correct performance on anti-saccade trials requires three components: i) inhibition of a saccade towards a stimulus ii) transposing the stimulus to the opposite direction, and iii) generating a volitional movement to the goal location. A common assumption of electrical microstimulation is that the imposed effects sum with pre-existing levels of neural activity. Providing additional activation in the SEF through stimulation should result in a stronger command sent downstream and result in shorter latency anti-saccades. However, we observed the opposite effect. Paradoxically, slower anti-saccades did not result in an improved error rate. Behavioral studies in humans and animals have shown that slower movements usually result in a lower error rate (Schouten and Bekker 1967; Wickelgren 1977; Chittka et al. 2009) and subsequent neural studies confirmed this (Bogacz et al. 2010).

In some ways, our results mirror those produced by short trains of transcranial magnetic stimulation (TMS). Many studies suggest that TMS has a disruptive influence of neural activity (see Pascual-Leone et al. 2001 for review). TMS of frontal areas generally results in longer RTs on anti-saccade trials (Nagel et al. 2008). Microstimulation may have a disruptive influence during a cognitively demanding task resulting in longer RTs and greater error rates on anti-saccade trials. An alternative suggestion is that microstimulation may introduce a competing motor program that prevents the normal development of neural processes in the SEF via a competitive interaction. According to this view, the competing motor program would result in more errors and require more time for the brain to produce the appropriate motor command.

4.4.2 - Neuromuscular responses to SEF stimulation

Based on work in chapter three and previous SC stimulation studies (Corneil et al. 2007), short-duration stimulation recruited neck muscles without an accompanying gaze shift. Here, we consider the physiological activity following SEF stimulation during the fixation interval. Background EMG activity began to differentiate ~450 ms before stimulus onset and prior to any knowledge of the ensuing gaze shifts, the monkeys had higher levels of activity on pro-saccade trials. However, evoked activity was greater on anti-saccade trials as stimulation was delivered closer to stimulus onset, which is notable especially considering the increase above baseline of EMG activity.

During the post-stimulus period, we can see a slight increase (when target was to the right of the FP) or decrease (when target was to the left of the FP) in activity that is

related to the visual presentation of a stimulus. We also observed a lateralized, task dependent modulation of neck muscle recruitment. Based on the FP, the subject can prepare to generate a pro- or anti-saccade but cannot program the direction of the ensuing gaze shift. Once the monkey has knowledge of stimulus location the SEF ipsilateral to stimulus location would activate the contralateral neck muscle driving a gaze shift away from the target. Neural activity in the SEF contralateral to the stimulus would not show any differential activity between pro- and anti-saccades; therefore, no difference would be seen in the neck muscle ipsilateral to the stimulus. These results are consistent with a role for the SEF in the contextual modulation of behavior.

In the previous section, we speculate that our behavioral results could be explained by two plausible mechanisms. Our physiological results are consistent with the latter mechanism. Electrical microstimulation results in preferential activation of the largest and most excitable elements of cortex and these elements tend to project to subcortical nuclei (Calvin and Sypert 1976; Nowak and Bullier 1996; Deschenes et al. 1979; Finlay et al. 1976; Macpherson et al. 1982; Stoney, Jr. et al. 1968; Swadlow 1988; Swadlow 1985). These stimulated neurons are more likely to project to subcortical nuclei involved in specific behavior such as eye movements (Tehovnik et al. 2003; Tehovnik and Sommer 1997) and head movements as demonstrated here.

4.4.3 – Contextual control of eye-head gaze shifts

The ability to respond appropriately to a stimulus is an important aspect of behavior. The neural basis for the contextual control of movement appears to be distributed across many cortical and subcortical areas (Munoz and Everling 2004; Curtis

et al. 2005). One of the defining characteristics of eye-head gaze shifts is that the CNS can generate amplitude matched gaze shifts with varying contributions of the eye and head (Constantin et al 2004; Oommen and Stahl 2004). A number of other high-level processes can affect the onset of the head movement and the contribution of the head to the gaze shift such as target predictability, oculomotor preparation, reward and behavioural state (Bizzi et al. 1972; Freedman and Sparks 1997; Oommen et al. 2004; Zangemeister and Stark 1982; Rezvani and Corneil 2008; Corneil et al. 2007).

It is currently thought that the SEF encodes gaze shifts in both humans (Petit and Beauchamp 2003; Reuter et al. 2010) and non-human primates (Martinez-Trujillo et al. 2003), with downstream mechanisms specifying the specific kinematics of the eye and head. Recently, evidence demonstrates a role for the SEF in the generation of head movements independent of overt changes in gaze (Chen and Walton 2005). In addition to providing low-level motor output, extracellular recording studies in the SEF have identified task related neurons that are preferentially activated for learning and monitoring eye movements, oculomotor sequencing and goal directed action in both humans and monkeys (Schlag-Rey et al. 1997; Stuphorn et al. 2000; Chen and Wise 1995b; Chen and Wise 1995a; Lu et al. 2002; Gaymard et al. 1990; Muri et al. 1998; Muri et al. 1995; Tobler and Muri 2002). Combined, these results suggest that the SEF might serve as an interface between low-level motor processing and high-level cognitive control of behavior.

4.4.4 - Summary

Our results suggest that the processes underlying anti-saccade performance manifest in the cephalomotor periphery. The recruitment patterns parallel neural activity and support a role for the SEF in the contextual control of eye-head gaze shifts. Because of the close nature between neural and neck EMG activity, it would appear likely that this signal would relay through direct projections to the premotor nuclei responsible for movement production. Regardless of the functional pathways, it would appear that the SEF acts as an interface between sensory perception and executive control over movements as aspects of the sensori-motor transformation during anti-saccades can be observed in the motor periphery following SEF stimulation.

Reference List

- Amador N, Schlag-Rey M, Schlag J (2004) Primate antisaccade. II. Supplementary eye field neuronal activity predicts correct performance. *J Neurophysiol* 91:1672-1689
- Bizzi E, Kalil RE, Morasso P (1972) Two modes of active eye-head coordination in monkeys. *Brain Res* 40:45-48
- Bogacz R, Wagenmakers EJ, Forstmann BU, Nieuwenhuis S (2010) The neural basis of the speed-accuracy tradeoff. *Trends Neurosci* 33:10-16
- Calvin WH, Sypert GW (1976) Fast and slow pyramidal tract neurons: an intracellular analysis of their contrasting repetitive firing properties in the cat. *J Neurophysiol* 39:420-434
- Chapman BB, Corneil BD (2008) Properties of human eye-head gaze shifts in an anti-gaze shift task. *Vision Res* 48:538-548
- Chapman BB, Corneil BD (2011) Neuromuscular recruitment related to stimulus presentation and task instruction during the anti-saccade task. *Eur J Neurosci* 33:349-360
- Chapman, B. B., Pace, M. A., Green, K., and Corneil, B. D. Contextual modulation of neck muscle activity evoked by stimulation of the supplementary eye fields. *Society for Neuroscience*. 676.8. 2010.
- Ref Type: Conference Proceeding

- Chen LL, Walton MM (2005) Head movement evoked by electrical stimulation in the supplementary eye field of the rhesus monkey. *J Neurophysiol* 94:4502-4519
- Chen LL, Wise SP (1995a) Neuronal activity in the supplementary eye field during acquisition of conditional oculomotor associations. *J Neurophysiol* 73:1101-1121
- Chen LL, Wise SP (1995b) Supplementary eye field contrasted with the frontal eye field during acquisition of conditional oculomotor associations. *J Neurophysiol* 73:1122-1134
- Chittka L, Skorupski P, Raine NE (2009) Speed-accuracy tradeoffs in animal decision making. *Trends Ecol Evol* 24:400-407
- Corneil BD, Munoz DP, Olivier E (2007) Priming of head premotor circuits during oculomotor preparation. *J Neurophysiol* 97:701-714
- Corneil BD, Olivier E, Richmond FJ, Loeb GE, Munoz DP (2001) Neck muscles in the rhesus monkey. II. Electromyographic patterns of activation underlying postures and movements. *J Neurophysiol* 86:1729-1749
- Curtis CE, Cole MW, Rao VY, D'Esposito M (2005) Canceling planned action: an fMRI study of countermanding saccades. *Cereb Cortex* 15:1281-1289
- Deschenes M, Labelle A, Landry P (1979) Morphological characterization of slow and fast pyramidal tract cells in the cat. *Brain Res* 178:251-274
- Everling S, Fischer B (1998) The antisaccade: a review of basic research and clinical studies. *Neuropsychologia* 36:885-899

Finlay BL, Schiller PH, Volman SF (1976) Quantitative studies of single-cell properties in monkey striate cortex. IV. Corticotectal cells. *J Neurophysiol* 39:1352-1361

Freedman EG, Sparks DL (1997) Eye-head coordination during head-unrestrained gaze shifts in rhesus monkeys. *J Neurophysiol* 77:2328-2348

Gaymard B, Pierrot-Deseilligny C, Rivaud S (1990) Impairment of sequences of memory-guided saccades after supplementary motor area lesions. *Ann Neurol* 28:622-626

Hallett PE (1978) Primary and secondary saccades to goals defined by instructions. *Vision Res* 18:1279-1296

Lu X, Matsuzawa M, Hikosaka O (2002) A neural correlate of oculomotor sequences in supplementary eye field. *Neuron* 34:317-325

Macpherson J, Wiesendanger M, Marangoz C, Miles TS (1982) Corticospinal neurones of the supplementary motor area of monkeys. A single unit study. *Exp Brain Res* 48:81-88

Martinez-Trujillo JC, Wang H, Crawford JD (2003) Electrical stimulation of the supplementary eye fields in the head-free macaque evokes kinematically normal gaze shifts. *J Neurophysiol* 89:2961-2974

Munoz DP, Everling S (2004) Look away: the anti-saccade task and the voluntary control of eye movement. *Nat Rev Neurosci* 5:218-228

- Muri RM, Heid O, Nirkko AC, Ozdoba C, Felblinger J, Schroth G, Hess CW (1998) Functional organisation of saccades and antisaccades in the frontal lobe in humans: a study with echo planar functional magnetic resonance imaging. *J Neurol Neurosurg Psychiatry* 65:374-377
- Muri RM, Rivaud S, Vermersch AI, Leger JM, Pierrot-Deseilligny C (1995) Effects of transcranial magnetic stimulation over the region of the supplementary motor area during sequences of memory-guided saccades. *Exp Brain Res* 104:163-166
- Nagel M, Sprenger A, Lencer R, Kompf D, Siebner H, Heide W (2008) Distributed representations of the "preparatory set" in the frontal oculomotor system: a TMS study. *BMC Neurosci* 9:89
- Nowak LG, Bullier J (1996) Spread of stimulating current in the cortical grey matter of rat visual cortex studied on a new in vitro slice preparation. *J Neurosci Methods* 67:237-248
- Olson CR, Gettner SN (2002) Neuronal activity related to rule and conflict in macaque supplementary eye field. *Physiol Behav* 77:663-670
- Oommen BS, Smith RM, Stahl JS (2004) The influence of future gaze orientation upon eye-head coupling during saccades. *Exp Brain Res* 155:9-18
- Pascual-Leone A, Davey N, Rothwell J, Wasserman E, Puri BK (2001) *Handbook on transcranial magnetic stimulation*. Oxford University Press, Oxford

- Petit L, Beauchamp MS (2003) Neural basis of visually guided head movements studied with fMRI. *J Neurophysiol* 89:2516-2527
- Reuter B, Kaufmann C, Bender J, Pinkpank T, Kathmann N (2010) Distinct neural correlates for volitional generation and inhibition of saccades. *J Cogn Neurosci* 22:728-738
- Rezvani S, Corneil BD (2008) Recruitment of a head-turning synergy by low-frequency activity in the primate superior colliculus. *J Neurophysiol* 100:397-411
- Schall JD (1991) Neuronal activity related to visually guided saccades in the frontal eye fields of rhesus monkeys: comparison with supplementary eye fields. *J Neurophysiol* 66:559-579
- Schiller PH, Chou IH (1998) The effects of frontal eye field and dorsomedial frontal cortex lesions on visually guided eye movements. *Nat Neurosci* 1:248-253
- Schlag J, Schlag-Rey M (1987) Evidence for a supplementary eye field. *J Neurophysiol* 57:179-200
- Schlag-Rey M, Amador N, Sanchez H, Schlag J (1997) Antisaccade performance predicted by neuronal activity in the supplementary eye field. *Nature* 390:398-401
- Schouten JF, Bekker JA (1967) Reaction time and accuracy. *Acta Psychol (Amst)* 27:143-153

- Shook BL, Schlag-Rey M, Schlag J (1990) Primate supplementary eye field: I. Comparative aspects of mesencephalic and pontine connections. *J Comp Neurol* 301:618-642
- Sommer MA, Tehovnik EJ (1999) Reversible inactivation of macaque dorsomedial frontal cortex: effects on saccades and fixations. *Exp Brain Res* 124:429-446
- Stoney SD, Jr., Thompson WD, Asanuma H (1968) Excitation of pyramidal tract cells by intracortical microstimulation: effective extent of stimulating current. *J Neurophysiol* 31:659-669
- Stuphorn V, Taylor TL, Schall JD (2000) Performance monitoring by the supplementary eye field. *Nature* 408:857-860
- Swadlow HA (1985) Physiological properties of individual cerebral axons studied in vivo for as long as one year. *J Neurophysiol* 54:1346-1362
- Swadlow HA (1988) Efferent neurons and suspected interneurons in binocular visual cortex of the awake rabbit: receptive fields and binocular properties. *J Neurophysiol* 59:1162-1187
- Tehovnik EJ, Slocum WM, Schiller PH (2003) Saccadic eye movements evoked by microstimulation of striate cortex. *Eur J Neurosci* 17:870-878
- Tehovnik EJ, Sommer MA (1997) Electrically evoked saccades from the dorsomedial frontal cortex and frontal eye fields: a parametric evaluation reveals differences between areas. *Exp Brain Res* 117:369-378

Tobler PN, Muri RM (2002) Role of human frontal and supplementary eye fields in double step saccades. *Neuroreport* 13:253-255

Wickelgren WA (1977) Speed-accuracy tradeoff and information processing. *Acta Psychologica* 41:67-85

Zangemeister WH, Stark L (1982) Types of gaze movement: variable interactions of eye and head movements. *Exp Neurol* 77:563-577

Chapter 5

5.1 - General discussion

The work presented in this thesis had three main objectives. 1) To identify if aspects of sensori-motor transformation are reflected in neck muscle activity. 2) To examine the SEF's role in the neuromuscular control of orienting head movements. 3) To examine the contribution of the SEF to the contextual control of eye-head gaze shifts. In this chapter, I will begin by outlining the three experiments with a focus on the important results and how they relate to the objectives of the thesis. Following this, I will discuss relevant experimental design issues and limitations inherent to the tasks and techniques utilized. Finally, I will conclude by discussing these findings with respect to directions for future research.

5.2 - Objective One: top-down and bottom-up EMG activity

The experiment in chapter two examined the top-down and bottom-up activity in the motor periphery by recording neck muscle activity. The anti-saccade task allowed us to achieve this objective as it requires the monkey to inhibit a saccade towards a stimulus, transpose that stimulus to its opposite location, and generate an appropriate saccade. One benefit of our task design specifically allowed for the quantification of the timing and metrics of top-down EMG activity. Although our fixation point duration was relatively short, the trial instruction (pro- or anti-saccade) was provided in advance of the subsequent movement. By requiring the monkeys to fixate during the instruction period,

the subjects had to prepare for either a pro- or anti-saccade. The fixation period was sufficient to see the influence of top-down activity related to task consolidation developing on the neck muscles. Several key findings should be reiterated here. First, we observed bottom-up activity related to the presentation of a visual response. During anti-saccade trials, we demonstrated that presentation of a visual stimulus results in a transient recruitment of the neck muscle synergy used to orient the head in the wrong direction, even though subjects would correctly orient away from the stimulus. Similar to behavioral reports in humans (Chapman and Corneil 2008), we did not observe head-only errors (where the head orients towards the target but gaze remains stable due to the vestibulo-ocular reflex). However, the visual response was likely responsible for a small head movement that was well below our within-trial detection criteria. Second, we also reported top-down, task-related activity on the neck muscles. During the fixation period, both monkeys showed task-dependent increase in neck EMG activity. Although the activity was different between monkeys, it demonstrates that the neural mechanisms engaged following consolidation of task instruction can influence the motor periphery, even in head-restrained subjects. Control trial data collected from the monkeys in chapter four demonstrated pre-stimulus EMG activity that was similar to monkey *gr*. Finally, the profile of EMG activity prior to erroneous anti-saccades is essentially identical to correct pro-saccades. These findings address the first objective of this thesis by definitively indicating aspects of both top-down and bottom-up activity on the neck muscles. The results also suggest that activity seen on neck muscles during the fixation period is reflective of trial type and predictive of behaviour.

One inherent limitation of the experimental design is that monkeys require many training sessions to adequately perform the task. We cannot be certain that the top-down strategies are present immediately upon starting the task or require a large number of trials. This could result in differences when compared to human studies as humans are immediately capable of performing the anti-saccade task. Additionally, the neural areas responsible for the top-down signal cannot be determined; we can only conclude that they culminate in the motor periphery. This short-coming inspired the experimental question presented in chapter four.

5.3 - Objective Two: examining SEFs role in neuromuscular control

Chapter three describes an experiment in which SEF stimulation was delivered in concert with neck muscle recordings during a pro-saccade task. Stimulation was always provided from a central location prior to the monkeys orienting to one of eight potential targets. We utilized this experimental design for several reasons. First, we employed the exact same task constraints in previous studies (Elsley et al. 2007) to facilitate direct comparison of evoked activity from the FEF. Second, the presentation of a central fixation point allowed for consistent background activity on the neck muscle. Finally, the presentation of eight potential targets limits the amount of preparatory activity observed (Basso and Wurtz 1998). Although this task was relatively simplistic considering the functional recruitment of the SEF in more cognitively demanding tasks, it was specifically chosen in order to examine the basic neuromuscular response properties following SEF stimulation.

This study demonstrated that neck EMG activity can be evoked by SEF stimulation. A number of features of EMG activity are notable. First, we evoked EMG activity throughout a wide range of SEF sites, yet observed no distinct topography of stimulation sites. Second, EMG activity almost always preceded gaze shift onset and occurred even without an accompanying gaze shift. Perhaps due to the broad overlap in anatomical connectivity between these areas and similar interconnections with cortical and subcortical oculomotor structures, these results are very similar to what was reported following FEF stimulation (Elsley et al. 2007). On trials where gaze shift onset preceded EMG activity, it is likely that other muscles assisted in orienting the head. These results allowed us to complete objective two and characterize the neuromuscular response following SEF stimulation. This project also allowed us to construct part of the experimental design implemented in chapter four, specifically demonstrating that stimulation can result in neck muscle activity without evoking a gaze shift.

Although we described our rationale for employing our experimental design, some drawbacks were associated with the experiment. We could not investigate certain issues such as reference frame coding with the SEF, as we constrained our subjects to a central location at the beginning of each trial, and we did not vary the initial position of the eyes or head. Second, although we demonstrated SEF stimulation results in the recruitment of neck muscles, the pathways through which the signal reaches neck muscle motoneurons are unknown. The major pathways were discussed in chapter one and likely include a direct pathway from the SEF to the premotor nuclei involved in head movement. However, we cannot rule out indirect pathways to these same nuclei via the

FEF and/or SC. Issues regarding how to address this problem will be discussed in a following section.

5.4 - Objective Three: contextual recruitment of neck muscles following SEF stimulation

We observed task-related activity on the neck muscles in chapter two and speculated that the SEF is a logical candidate for providing these top-down neuromuscular commands. We combined SEF stimulation while recording neck muscles while monkeys performed a pro- and anti-saccade task. An important design feature was the use of short-duration stimulation (30 ms). Based on results in chapter 3, we were able to evoke neck muscle activity without an accompanying gaze shift. Other studies examining the SEFs role in gaze shift control have used much longer stimulation durations. However, this project focused on the neuromuscular control of gaze shifts and a 30 ms stimulation duration was long enough to elicit a neck EMG response. Borrowing logic from other short-duration stimulation paradigms (Corneil et al. 2007), we delivered 30 ms stimulation duration at multiple points in the fixation and post-stimulus period during both pro- and anti-saccades. This allowed us to construct a timeline of how the cephalomotor command evoked by SEF stimulation evolves with the consolidation of task instruction and stimulus presentation.

Several key behavioral and physiological findings are of note in chapter four. SEF stimulation primarily resulted in progressively larger effects during the preparation of anti-saccades. An increase in anti-saccade RT was found for both contralateral and ipsilateral goal locations as stimulation was provided closer to movement onset. In addition, we found an increase in anti-saccade error rates when stimulation was provided

in the post-stimulus period. As stimulation was delivered later in the fixation period, evoked activity was larger on anti-saccade trials. Finally, during the post-stimulus period, a significant increase of anti-saccade EMG activity was observed only with a contralateral goal location. No significant changes were found during pro-saccades with contralateral or ipsilateral goal location. However, a decrease in pro-saccade error rates was shown when stimulation was provided in the post-stimulus period. No significant modulation of EMG activity was observed on pro-saccade trials in either the fixation or post-stimulus period. These results support objective three and are consistent with the SEFs role in the contextual control of eye-head gaze shifts.

5.5 – Implications of our results in sensori-motor transformations

Initial theories on information processing in the brain have used a theoretical framework that suggests that the sensori-motor transformation is serial in nature (Pylyshyn 1984; Newell and Simon 1972). The brain initially transforms sensory information into perceptual representations, constructs knowledge about the environment and makes decisions, finally implementing this decision through acting upon the initial stimulus. However, neurophysiological evidence appears to be at odds with many of the assumptions underlying serial information processing. Many recent results are not compatible with a discrete sensory, cognitive and motor systems underlying the neural computations of sensori-motor transformations (Lebedev and Wise 2002). Instead, neurophysiological results appear to support an alternative view where sensori-motor transformations occur in a continuous and parallel manner in many neural areas distributed throughout the brain (Cisek and Kalaska 2010). When sensori-motor

transformations are examined experimentally, it appears that the parallel processes for behavior appear as two waves of activation: an early wave that recognizes external stimuli and specifies multiple potential actions, and a second wave of activity that specifies a specific action. Following presentation of a visual stimulus, a quick activation of the dorsal visual system is observed which also engages acknowledged motor systems such as the FEF and SC (Schmolesky et al. 1998). Recent studies have identified a bottom-up visual response that also occurs in the motor periphery (Corneil et al. 2004; Pruszynski et al. 2010). A fast dorsal activation system also appears to use visual information to specify potential actions (Milner and Goodale 1995; Gibson 1979).

Project one furthers the notion of parallel processing by demonstrating that these processes occur during contextual control of movement. A visual stimulus presented on anti-saccade trials resulted in activation of neck muscles; however, in our case it specifies an incorrect action specification during anti-saccades as neck muscle activation would favor a head turn towards the stimulus. After action specification, a slower selection process is used to integrate information and make a decision regarding action (Ledberg et al. 2007). It appears that neuromuscular data from chapter two extends the parallel nature of information processing. On correct anti-saccade trials, the visual response is followed by a slower but appropriate motor response orienting the head away from the stimulus. It is generally accepted that the SEF has task related neurons that are involved in affecting overt behavior (Olson and Gettner 2002; Olson et al. 2000; Schlag-Rey et al. 1997; Schall 1991). Project three extends this finding by showing task dependent neck muscle activity consistent with the SEFs involvement in specifying action during contextual situations. Chapters two and four also show evidence of task consolidation prior to a flashed

stimulus. All subjects demonstrated task-related activity in the motor periphery prior to presentation of an eccentric stimulus and our results from chapter four are consistent with the SEFs role in the cognitive control of behavior.

Behavioral responses to stimuli require sensori-motor control and it appears that neural control operates continuously and in parallel. We have shown that aspects of the sensori-motor process do not simply remain in the CNS but also manifest in the motor periphery during different contextual situations. Decisions to appropriately act upon a stimulus appear to be made through multiple areas in a distributed neural network including the SEF, and the product that emerges from a competitive process of these neural areas is behavior.

5.6 – Methodological issues

The ability to alter the neuronal activity while measuring the resulting effects is useful in understanding neural processing. Extracellular electrical stimulation is a common tool used to modify neural activity and does so by changing the voltage gradient that is maintained across a cell membrane. Although some have argued that it is not an ideal method for studying mechanisms underlying neural functioning, microstimulation has contributed to many clinical advances (Bierer and Middlebrooks 2004; Bierer and Middlebrooks 2002; Middlebrooks and Bierer 2002; Dostrovsky and Lozano 2002; Dostrovsky et al. 2000). In addition, electrical stimulation has been instrumental in demonstrating causal links between neural functioning and specific behavior such as eye movements (Tehovnik and Lee 1993; Robinson 1972; Robinson and Fuchs 1969).

Chapters three and four utilized microstimulation of the SEF using different parameters, but here we consider the suitability of this technique to achieve our objectives. First, it is well known that surface area of the tip of the electrode is positively correlated with the amount of current required to activate neural tissue (Yeomans 1990; Bagshaw and Evans 1976; Keating and Gooley 1988). Therefore, macroelectrodes require millampere currents whereas microelectrodes require microampere currents. Both projects utilized microelectrodes to minimize damage to neural tissue and we subsequently required relatively small amounts of current (100 μ A) for both projects. Second, both projects used biphasic stimulation with an initial cathodal pulse. The resting potential of a neuron is -70-80 millivolts inside the cell compared to outside. The initial cathodal pulse of microstimulation attracts the positively charged cations outside the cell, resulting in a depolarization of the membrane, potentially initiating action potentials in the surrounding neurons. To understand the excitability of neurons surrounding the microelectrode tip, current can be interchanged with pulse duration to elicit a response (Tehovnik and Lee 1993; Tehovnik and Sommer 1997; Yeomans and Tehovnik 1988; Nowak and Bullier 1998). This is the common procedure used to determine strength-duration functions. As pulse duration is increased, current can be decreased to a level where no length of pulse duration will produce a response; this is termed the *rheobase* current. The excitability or *chronaxie* of a stimulated element is the minimum time over which an electric current double the strength of the rheobase needs to be applied to activate nerve cell. Pulse durations for stimulation of cortex that mediates saccadic eye movements range between 0.1-0.4 ms (Tehovnik et al. 2003; Tehovnik and Sommer 1997). In both projects two and three we used a pulse duration of 0.3 ms.

Although this is slightly different than pulse durations used in other experiments, it is within the accepted range to elicit a neural response. In addition, we have used the same pulse duration and frequency as previous experiments (Elsley et al. 2007) which allow us to attribute differences in results to the neural area being examined.

What are the presynaptic elements activated by microstimulation? The chronaxie for axons is 40x smaller than values for cell bodies, suggesting that when post-synaptic effects are observed it is likely axons and not cell bodies that are activated (Histed et al. 2009; Nowak and Bullier 1998). It has been established that even a single electrical pulse delivered to cortical and subcortical tissue can activate cells transynaptically and laterally (Stoney, Jr. et al. 1968; Asanuma and Rosen 1973; Jankowska et al. 1975). For example, providing a train of four 30 μ A pulses (400hz) can transynaptically and laterally activate areas 2-3 mm from the electrode tip and can reach up to 4mm in cortical areas (Grinvald et al. 1994; McIlwain 1982; Sloviter et al. 2002). This presents a problem when one is activating an area with a diameter of 8 mm around the electrode tip: how can microstimulation evoke precise behavioral responses when lateral spread of activity is so prevalent in neural tissue even at the lowest currents? First, it is thought that microstimulation disproportionately activates the most excitable elements of cortex such as pyramidal cells, these elements project subcortically and not laterally (Calvin and Sypert 1976; Stoney, Jr. et al. 1968; Nowak and Bullier 1996; Finlay et al. 1976). These subcortical networks are likely involved in precise behavioral responses such as saccadic eye movements and neck muscle responses. Second, lateral projections may not significantly contribute to precise evoked behavior because lateral neurons are frequently unmyelinated and therefore are relatively unexcitable (Nowak and Bullier 1996;

Swadlow 1985). Finally, directly activated neurons make a larger contribution to a response as they are more synchronously activated compared to laterally activated cortical neurons (Tolias et al. 2005).

Over its century long history, microstimulation has provided many insights into the causal relationship between neural activity and behavior. Microstimulation results in a distributed pattern of activated neural activity through axonal activation (Histed et al. 2009; Nowak and Bullier 1998). Although we lack a complete understanding of its effects on individual neurons, microstimulation (and increasingly transcranial magnetic stimulation) have important relevance to both clinical and research applications.

The nature of EMG recordings has inherent limitations as well. As previously mentioned the neck has >24 muscles that can potentially cause head motion. We only sampled a representative portion of ten neck muscles and tended to avoid the ventral neck muscles due to difficulties in implanting electrodes. The muscles we recorded from are also relatively complex. They have many different fiber types and are multi-compartmental. In addition, they can be large and have different innervation patterns at different points along the muscles. There is evidence that the brain can contribute to muscle compartments differently (Anderson et al. 1971). During voluntary behavior, slow-twitch muscle fibers are activated first followed by larger fast twitch muscle fibers. It is unknown if stimulation results in similar activation patterns and we cannot make any statements regarding this issue. Further, we use an electrode that likely samples many motor units and we attempt to situate the electrode in the middle of the muscle belly. Thus, the signals we analyze and interpret are only a gross sample of the neck muscle activity.

5.7 - *General limitations*

Collecting neural data from a head-unrestrained monkey poses a number of significant challenges. One challenge is the postural position each monkey adopts throughout an experimental session, which can influence the tonic activation of the neck muscles. To control for this, we restricted trunk rotation of the monkey. Also targets were presented in equal probability to the left or right of the FP which encouraged the monkey to adopt a forward body posture. In addition, the monkeys can shake, or perform other activities that during a trial that can distort EMG activity. The movement related artifacts were excluded from the data analysis.

The second caveat relates to the performance of the animal in a head-unrestrained environment. Head-restrained designs are generally desirable because they limit the number of training sessions and result in better performance since the monkeys have fewer modes of distraction. Although we try to minimize light and noise in the surrounding environment, some distractions are inevitable and behaving monkeys are particularly susceptible to the disruptions with the head-unrestrained. Although much of our data were collected in the head-restrained condition in all three projects, we did not observe any difference between the timing and magnitudes of EMG activity between the two head restraint conditions. Therefore, neck EMGs provide a useful short-cut during head-restrained experiments. We always verified our head-restrained results in the head-unrestrained condition and consistent with previous work we observed no difference between the conditions.

5.8 - Future directions

The results that were obtained in this thesis inspire several interesting future projects. In chapter two, we described the contextual signal that is present on neck muscles in monkeys. The recording of neck muscles during an anti-saccade task in humans could provide additional insights into any interspecies differences in overtraining and the contextual control of neck muscles. Preliminary results have shown that stimulating human FEF through TMS results in neck muscle activity. Following the logic proposed in chapter four, neck muscle recording can be combined with a non-invasive stimulation method of the SEF, such as transcranial magnetic stimulation (TMS), in humans.

A logical extension of chapter four would be to record single-unit in the SEF and neck muscle activity during different contextual tasks. Similar to previous studies (Chen and Walton 2005), monkeys can be trained to orient the head and the eyes in differing locations prior to making a gaze shift. A separate paradigm would alter the expectations of future movements (Oommen et al. 2004). By varying the initial positions of the eyes and head or using a double step task, the contribution of the head could vary considerably. Recording SEF activity during such tasks would directly address the SEFs role in neuromuscular control.

Third, we previously described many areas that are involved in the production of anti-saccades such as the dlPFC and FEF. The dlPFC shows context dependant signals and would be a logical place to continue attempting to identify other potential areas of origin for the contextual signals we observed in chapter two. Recording studies in the FEF has shown that pre-stimulus activity is larger on pro-saccades than on anti-saccades.

By stimulating the FEF and recording neck muscles during an anti-saccade task we would expect reflections of higher pro-saccade activity to be present on the neck muscles. Preliminary analysis has demonstrated no difference between evoked pro- and anti-neck muscle activity during the fixation period. Consistent with the SEF results, a significant increase in activity on the r-OCI was observed during the post-stimulus period on anti-saccade trials when the goal location was contralateral to stimulation.

A fourth avenue for future work emerges from the experiment conducted in chapter three. We demonstrated that stimulation of both the SEF, and previously the FEF, results in neck muscle activity that is time locked to stimulation onset and occurs even in the absence of gaze shifts. By stimulating in areas that occur earlier in the oculomotor hierarchy, researchers have been able to evoke visual percepts and train monkeys to make a saccade towards these illusory stimuli (Chen and Tehovnik 2007). By combining neck muscle recordings with stimulation in areas such as LIP or extrastriate cortex, we could potentially see a different pattern of neck muscle activity that would help differentiate evoked programs from motor programs from those generated in response to sensory precepts. One could hypothesize that EMG activity would be associated with the gaze shift and not stimulation. Stimulation in these areas would evoke a phosphene and potentially neck muscle responses related to volitional movement and not microstimulation.

Finally, in project three and four we were able to identify the signal that arrived on the neck muscles following SEF stimulation but we were unable to determine how this signal arrived there. We believe there are two potential pathways, one from the SEF directly to the subcortical nuclei involved in generating eye head movements, and another

would be from the SEF through the FEF and SC to these same nuclei. One could combine inactivation of the FEF or SC with stimulation of the SEF in both tasks in order to determine the efferent pathways from the SEF to examine the timing and patterns of neck muscle activity.

5.9 - Conclusions

The three objectives of the experiments presented in this thesis were to identify aspects of the contextual control of head movements, to identify the neuromuscular signals originating from the SEF and to identify if the SEF is a potential candidate for the contextual signals we identified on neck muscles. The three experimental chapters presented in this thesis have addressed these objectives, and have hopefully made a novel contribution to the understanding of the cephalomotor commands. We have shown that top-down and bottom-up activity is reflected in neck muscle activity, which should help identify or constrain aspects of descending contextual control signals. Further, we have described eye-head gaze shifts following SEF stimulation and have shown that neck muscle activity is consistent with the contextual control of eye-head gaze shifts. Although this thesis has provided the answers to some questions of motor control, there still remain many questions to be answered. The projects described in the previous section represent one more step in resolving some remaining questions regarding eye-head control.

Reference List

- Anderson ME, Yoshida M, Wilson VJ (1971) Influence of superior colliculus on cat neck motoneurons. *J Neurophysiol* 34:898-907
- Asanuma H, Rosen I (1973) Spread of mono- and polysynaptic connections within cat's motor cortex. *Exp Brain Res* 16:507-520
- Bagshaw EV, Evans MH (1976) Measurement of current spread from microelectrodes when stimulating within the nervous system. *Exp Brain Res* 25:391-400
- Basso MA, Wurtz RH (1998) Modulation of neuronal activity in superior colliculus by changes in target probability. *J Neurosci* 18:7519-7534
- Bierer JA, Middlebrooks JC (2002) Auditory cortical images of cochlear-implant stimuli: dependence on electrode configuration. *J Neurophysiol* 87:478-492
- Bierer JA, Middlebrooks JC (2004) Cortical responses to cochlear implant stimulation: channel interactions. *J Assoc Res Otolaryngol* 5:32-48
- Calvin WH, Sypert GW (1976) Fast and slow pyramidal tract neurons: an intracellular analysis of their contrasting repetitive firing properties in the cat. *J Neurophysiol* 39:420-434
- Chapman BB, Corneil BD (2008) Properties of human eye-head gaze shifts in an anti-gaze shift task. *Vision Res* 48:538-548
- Chen LL, Tehovnik EJ (2007) Cortical control of eye and head movements: integration of movements and percepts. *Eur J Neurosci* 25:1253-1264

- Chen LL, Walton MM (2005) Head movement evoked by electrical stimulation in the supplementary eye field of the rhesus monkey. *J Neurophysiol* 94:4502-4519
- Cisek P, Kalaska JF (2010) Neural mechanisms for interacting with a world full of action choices. *Annu Rev Neurosci* 33:269-298
- Corneil BD, Munoz DP, Olivier E (2007) Priming of head premotor circuits during oculomotor preparation. *J Neurophysiol* 97:701-714
- Corneil BD, Olivier E, Munoz DP (2004) Visual responses on neck muscles reveal selective gating that prevents express saccades. *Neuron* 42:831-841
- Dostrovsky JO, Levy R, Wu JP, Hutchison WD, Tasker RR, Lozano AM (2000) Microstimulation-induced inhibition of neuronal firing in human globus pallidus. *J Neurophysiol* 84:570-574
- Dostrovsky JO, Lozano AM (2002) Mechanisms of deep brain stimulation. *Mov Disord* 17 Suppl 3:S63-S68
- Elsley JK, Nagy B, Cushing SL, Corneil BD (2007) Widespread presaccadic recruitment of neck muscles by stimulation of the primate frontal eye fields. *J Neurophysiol* 98:1333-1354
- Finlay BL, Schiller PH, Volman SF (1976) Quantitative studies of single-cell properties in monkey striate cortex. IV. Corticotectal cells. *J Neurophysiol* 39:1352-1361
- Gibson JJ (1979) *The ecological approach to visual perception*. Houthon Mifflin, Boston

- Grinvald A, Lieke EE, Frostig RD, Hildesheim R (1994) Cortical point-spread function and long-range lateral interactions revealed by real-time optical imaging of macaque monkey primary visual cortex. *J Neurosci* 14:2545-2568
- Histed MH, Bonin V, Reid RC (2009) Direct activation of sparse, distributed populations of cortical neurons by electrical microstimulation. *Neuron* 63:508-522
- Jankowska E, Padel Y, Tanaka R (1975) Projections of pyramidal tract cells to alpha-motoneurons innervating hind-limb muscles in the monkey. *J Physiol* 249:637-667
- Keating EG, Gooley SG (1988) Disconnection of parietal and occipital access to the saccadic oculomotor system. *Exp Brain Res* 70:385-398
- Lebedev MA, Wise SP (2002) Insights into seeing and grasping: distinguishing the neural correlates of perception and action. *Behav Cogn Neurosci Rev* 1:108-129
- Ledberg A, Bressler SL, Ding M, Coppola R, Nakamura R (2007) Large-scale visuomotor integration in the cerebral cortex. *Cereb Cortex* 17:44-62
- McIlwain JT (1982) Lateral spread of neural excitation during microstimulation in intermediate gray layer of cat's superior colliculus. *J Neurophysiol* 47:167-178
- Middlebrooks JC, Bierer JA (2002) Auditory cortical images of cochlear-implant stimuli: coding of stimulus channel and current level. *J Neurophysiol* 87:493-507
- Milner AD, Goodale MA (1995) *The Visual Brain in Action*. Oxford University Press, Oxford, U.K.

- Newell A, Simon HA (1972) *Human Problem Solving*. Prentice-Hall, Englewood cliffs, N.J.
- Nowak LG, Bullier J (1996) Spread of stimulating current in the cortical grey matter of rat visual cortex studied on a new in vitro slice preparation. *J Neurosci Methods* 67:237-248
- Nowak LG, Bullier J (1998) Axons, but not cell bodies, are activated by electrical stimulation in cortical gray matter. I. Evidence from chronaxie measurements. *Exp Brain Res* 118:477-488
- Olson CR, Gettner SN (2002) Neuronal activity related to rule and conflict in macaque supplementary eye field. *Physiol Behav* 77:663-670
- Olson CR, Gettner SN, Ventura V, Carta R, Kass RE (2000) Neuronal activity in macaque supplementary eye field during planning of saccades in response to pattern and spatial cues. *J Neurophysiol* 84:1369-1384
- Oommen BS, Smith RM, Stahl JS (2004) The influence of future gaze orientation upon eye-head coupling during saccades. *Exp Brain Res* 155:9-18
- Pruszynski JA, King GL, Boisse L, Scott SH, Flanagan JR, Munoz DP (2010) Stimulus-locked responses on human arm muscles reveal a rapid neural pathway linking visual input to arm motor output. *Eur J Neurosci* 32:1049-1057
- Pylyshyn ZW (1984) *Computation and Cognition: Toward a Foundation for Cognitive Science*. MIT press, Cambridge, MA

- Robinson DA (1972) Eye movements evoked by collicular stimulation in the alert monkey. *Vision Res* 12:1795-1808
- Robinson DA, Fuchs AF (1969) Eye movements evoked by stimulation of frontal eye fields. *J Neurophysiol* 32:637-648
- Schall JD (1991) Neuronal activity related to visually guided saccadic eye movements in the supplementary motor area of rhesus monkeys. *J Neurophysiol* 66:530-558
- Schlag-Rey M, Amador N, Sanchez H, Schlag J (1997) Antisaccade performance predicted by neuronal activity in the supplementary eye field. *Nature* 390:398-401
- Schmolesky MT, Wang Y, Hanes DP, Thompson KG, Leutgeb S, Schall JD, Leventhal AG (1998) Signal timing across the macaque visual system. *J Neurophysiol* 79:3272-3278
- Slovin H, Arieli A, Hildesheim R, Grinvald A (2002) Long-term voltage-sensitive dye imaging reveals cortical dynamics in behaving monkeys. *J Neurophysiol* 88:3421-3438
- Stoney SD, Jr., Thompson WD, Asanuma H (1968) Excitation of pyramidal tract cells by intracortical microstimulation: effective extent of stimulating current. *J Neurophysiol* 31:659-669
- Swadlow HA (1985) Physiological properties of individual cerebral axons studied in vivo for as long as one year. *J Neurophysiol* 54:1346-1362

- Tehovnik EJ, Lee K (1993) The dorsomedial frontal cortex of the rhesus monkey: topographic representation of saccades evoked by electrical stimulation. *Exp Brain Res* 96:430-442
- Tehovnik EJ, Slocum WM, Schiller PH (2003) Saccadic eye movements evoked by microstimulation of striate cortex. *Eur J Neurosci* 17:870-878
- Tehovnik EJ, Sommer MA (1997) Electrically evoked saccades from the dorsomedial frontal cortex and frontal eye fields: a parametric evaluation reveals differences between areas. *Exp Brain Res* 117:369-378
- Tolias AS, Sultan F, Augath M, Oeltermann A, Tehovnik EJ, Schiller PH, Logothetis NK (2005) Mapping cortical activity elicited with electrical microstimulation using fMRI in the macaque. *Neuron* 48:901-911
- Yeomans JS (1990) *Principles of Brain Stimulation*. Oxford University Press, New York
- Yeomans JS, Tehovnik EJ (1988) Turning responses evoked by stimulation of visuomotor pathways. *Brain Res* 472:235-259

Appendix 1



11.01.10

***This is the 3rd Renewal of this protocol**

***A Full Protocol submission will be required in 2011**

Dear Dr. **Corneil**

Your Animal Use Protocol form entitled:

Sensory and Motor Roles for Neck Muscles in Visually-Guided Actions: Neural Mechanisms Underlying Recruitment and Kinesthesia

has had its yearly renewal approved by the Animal Use Subcommittee.

This approval is valid from **11.01.10 to 10.31.11**

The protocol number for this project remains as **2007-099**

1. This number must be indicated when ordering animals for this project.
2. Animals for other projects may not be ordered under this number.
3. If no number appears please contact this office when grant approval is received.
If the application for funding is not successful and you wish to proceed with the project, request that an internal scientific peer review be performed by the Animal Use Subcommittee office.
4. Purchases of animals other than through this system must be cleared through the ACVS office. Health certificates will be required.

REQUIREMENTS/COMMENTS

Please ensure that individual(s) performing procedures on live animals, as described in this protocol, are familiar with the contents of this document.

The holder of this *Animal Use Protocol* is responsible to ensure that all associated safety components (biosafety, radiation safety, general laboratory safety) comply with institutional safety standards and have received all necessary approvals. Please consult directly with your institutional safety officers.

c.c. K. Green, M. Pickering

The University of Western Ontario

Animal Use Subcommittee / University Council on Animal Care
Health Sciences Centre, London, Ontario CANADA – N6A 5C1
PH: 519-661-2111 ext. 86770 / FL 519 -661-2028 / www.uwo.ca / animal

Curriculum Vitae:

Brendan Blair Chapman

Born September 01, 1981 in Toronto, Ontario, Canada

Education:

Ph.D. Neuroscience – University of Western Ontario, London, Ontario, Canada. 2006-2011.

M.Sc. Neuroscience – University of Western Ontario, London, Ontario, Canada. 2005-2006

H.Ba. Psychology (Deans list) – University of Western Ontario, London, Ontario, Canada. 2000-2004

High School Diploma (Ontario Scholar) – Graduated from York Mills C.I., Toronto, Ontario. 1996-2000

Publications

Chapman, B.B. & Corneil, B.D. (2011). Neuromuscular recruitment related to stimulus presentation and task instruction during the anti-saccade task. *Eur J Neurosci.* 33(2): 1-12: 349-360.

Chapman, B.B., & Corneil, B.D. (2008). Properties of human eye-head gaze shifts in an anti-gaze shift task. *Vis. Research.* 48(4): 538-548.

Corneil, B.D., Munoz, D., **Chapman, B.B.**, Admans, T., Cushing, S. (2008). Overlap of Attention and Action: Neuromuscular correlates of covert orienting. *Nat. Neurosci.* 11(1): 13-5.

Scholarly Achievements

Society for Neuroscience Poster Presentation: **Chapman, B.B.**, Pace, M.A., Green, K. & Corneil, B.D. (11/2010). Contextual modulation of neck muscle activity evoked by stimulation of the supplementary eye fields.

Neural Control of Movement Poster Presentation: **Chapman, B.B.**, Pace, M.A. & Corneil, B.D. (04/2010) Neck muscle activity following stimulation of primate SEF: influence of parameters and behavioural tasks.

Neural Control of Movement Poster Presentation: Pace, M.A., **Chapman, B.B.** & Corneil, B.D. (04/2010). Neck muscle activity following stimulation of the primate SEF influence of initial position.

Society for Neuroscience Poster Presentation: **Chapman, B.B.** Elsley, J.K. & Corneil, B.D. (11/2008). Changes in neuromuscular responses evoked by stimulation of the primate FEF as a function of initial gaze position.

Society for Neuroscience Poster Presentation: **Chapman, B.B.** & Corneil, B.D. (2007). Neuromuscular correlates of the sensori-motor transformation during an anti-gaze shift task.

Group for Action and Perception Slide Presentation - **Chapman, B.B.** & Corneil, B.D. (2007). Neck muscle activity during an anti-gaze shift task.

Chapman, B.B. & Corneil, B.D. (2007). Head movement kinematics do not reflect neck muscle activity during an anti-gaze shift task. *Canadian Physiological Society Abstr.*

Society for Neuroscience Presentation 2006 - Munoz D.P., **Chapman B.B.**, Admans T., Cushing S., Corneil B.D. (2006). Neuromuscular consequences of reflexive covert orienting. *Soc Neurosci. Abstr.*

Society for Neuroscience Poster Presentation 2005 – **Chapman, B.B.** & Corneil, B.D. Properties of human and non-human primate eye-head gaze shifts in an anti-gaze shift task.

Masters Thesis – **Chapman, B.B.** & Corneil, B.D. (2006). Properties of human and non-human primate eye-head gaze shifts in an anti-gaze shift task.

Honors Thesis – **Chapman, B.B.**, Valyear, K. & Culham, J. (2004). Properties of mirror neurons in humans: an fMRI pilot study

Honors Project – **Chapman, B.B.** & MacDougall-Shackleton, S. (2004). Comparing HVC and song complexity across song bird species.

Scholarships and Awards

Ontario Graduate Scholarship – Doctoral Level. 2008-2009

Delta Tau chapter scholarship – Doctoral level, 2008.

Western Graduate Research Scholarship – University of Western Ontario, London, Ontario, Canada. 2006-2008

Cleveland Alumni Association scholarthip – Doctoral level, 2007.

Special University Scholarship – University of Western Ontario, London, Ontario, Canada. 2004-2006

Dean’s Scholar Award - University of Western Ontario, London, Ontario, Canada. 2004

Western Scholarship of Distinction - University of Western Ontario, London, Ontario, Canada. 2000

Related Work Experience

Appointed member of the University Council on Animal Care (Appointed by President Paul Davenport, Senate committee) – 2007-2010.

Guest lecturer – Psychology 215 – University of Western Ontario – “Introduction to neurons and visual perception”.

Graduate Program in Neuroscience representative to the Society of Graduate Students, 2005-2006

Teaching Assistant – University of Western Ontario, London, Ontario, Canada. 2004-2010.

- Psychology 650B: Psychology of Mental Health and Illness
- Psychology 1000: Introduction to Psychology
- Psychology 2115: Introduction to Sensation and Perception
- Psychology 2220: Introduction to Behavioural and Cognitive Neuroscience

Hon. Thesis Student in Dr. J. Culham’s laboratory at the University of Western Ontario 2003-2004.

Volunteer Assistant in Dr. S. MacDougall-Shackleton’s laboratory at the University of Western Ontario, London, Ontario, Canada – 2002-2004.

Other

Developer of non-human primate restraint systems and other related equipment.

Familiar with programming language used in MATLAB

Proficient in the use of the Microsoft Office suite of programs

Have worked with both human and animal subject pools